

# LCS<sup>3</sup>

3 DIMENSIONS  
OF EXCELLENCE

PERFORMANCE • SCALABILITY • EFFICIENCY

---

DATA CENTER  
LOCAL AREA NETWORK



**THE GLOBAL SPECIALIST**  
IN ELECTRICAL AND DIGITAL BUILDING INFRASTRUCTURES

 **legrand**<sup>®</sup>

# LCS<sup>3</sup>

3 DIMENSIONS  
OF EXCELLENCE

PERFORMANCE • SCALABILITY • EFFICIENCY



## Legrand Group

- 2 | **A global player**
- 4 | **Your multi-specialist partner for all your IT networks**
- 6 | **An extensive expertise in digital infrastructures**

## LCS<sup>3</sup>: a global offer



- Cabling system**
  - 8 | Performance
  - 18 | Scalability & Maintenance
  - 36 | Efficiency
- 19" Enclosures**
  - 40 | Astuteness
- Power Distribution Units**
  - 50 | Flexibility
  - 52 | Reliability & Safety
- Services & tools**
  - 60 | Support you can rely on



## Technical appendices

- 63** Standards
- 76** Fiber considerations when migrating to 100 Gigabit Ethernet and higher
- 80** The next step in fiber connectors
- 81** Cable fire ratings - Construction Projects Regulation (CPR) Applied to Structured Cabling
- 85** PoE standards and architecture
- 88** Structured cabling: the Legrand 25-year application warranty

## Catalogue pages

→ | [See p. 92 to 167](#)



# A global player

As the global specialist in electrical and digital building infrastructures, Legrand offers a comprehensive range of solutions and services tailored to numerous applications.

## IMPROVING LIVES BY TRANSFORMING SPACES, THE ESSENCE OF OUR PURPOSE

The Group's mission is to improve lives by transforming the spaces where people live, work and meet, with electrical and digital infrastructures and connected solutions that are simple, innovative and sustainable.

#LegrandImprovingLives



**Transforming spaces where people live**, from individual and collective housing to hotels and more.



**Transforming spaces where people work**, including data centers, offices and industrial sites.



**Transforming spaces where people meet**, from housing to shops, hospitals, schools, universities and more.

## THE LEGRAND GROUP IN A NUTSHELL

SALES IN CLOSE TO  
**180** COUNTRIES

AN ACTIVE INTERNATIONAL  
PRESENCE ESTABLISHED  
IN OVER **90** COUNTRIES

**5%** OF TOTAL BUDGET  
USED IN R&D

**€6,994** MILLIONS  
IN TOTAL SALES  
IN 2021

OVER  
**36,700**  
EMPLOYEES  
WORLDWIDE

## EXPERTISE AND COMMITMENTS, OUR MEANS TO ACHIEVE IT

The scope of its offering, its technological expertise, its leading positions, its international presence and the power of its brands combine to make Legrand a worldwide benchmark.

The meaning and values the Group's purpose statement conveys are integral to the development of each product and solution, and to each decision at Legrand. They also underpin the commitments the Group makes to its customers, to its employees, to its partners and to society as a whole.

By covering all needs, including emerging ones shaped by changing lifestyles and working habits, the Group's comprehensive, innovative and high-performance portfolio of solutions provides answers to the technological, societal and environmental challenges that we all face every day.

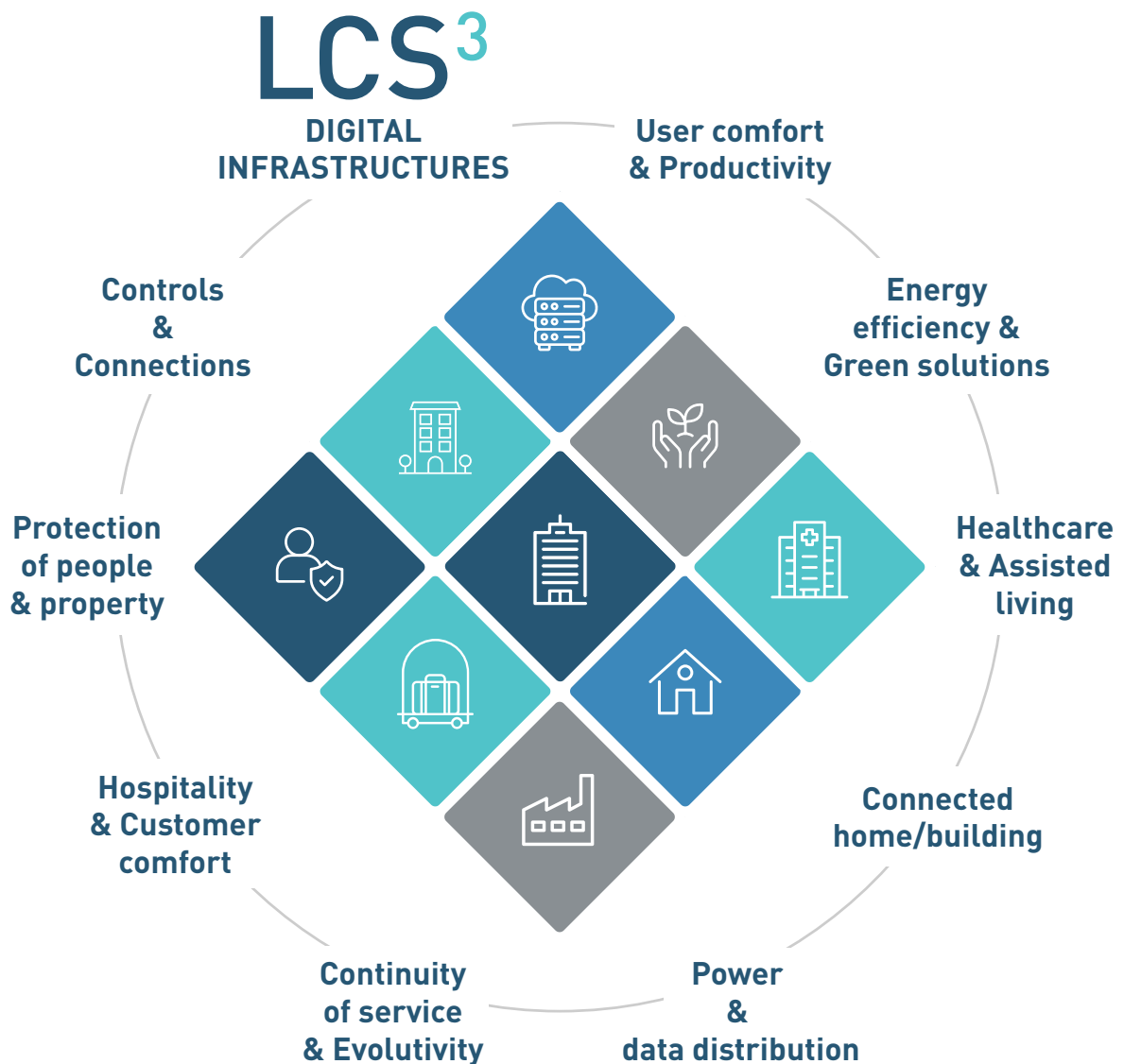

# Your multi-specialist partner for all your IT networks

Its investment in the development and design of structured cabling systems and solutions has enabled the Legrand group to expand its offer and achieve the highest level of performance. Legrand cabling systems currently provide high-quality connectivity to more than 200 million devices, making the Legrand group a world leader in communication networks for data transmission.

## A PORTFOLIO OF SPECIALIST BRANDS

### ■ AFCO systems (USA)

An industry leader in the design, engineering and manufacture of racks, cabinets, enclosures, and air containment systems.

### ■ C2G (USA)

An industry leader in end-to-end connectivity solutions serving commercial applications in a variety of markets.

### ■ Electrorack (USA)

A leading manufacturer of enclosures, cabinets, power and cooling for commercial data communications applications.

### ■ Luxul (USA)

The leading innovator of simple-to-deploy professional grade IP networking solutions for use by custom installation professionals.

### ■ Middle Atlantic Products (USA)

A manufacturer of exceptional support and protection products to mount integrated AV systems in residential, commercial, broadcast, and security applications.

### ■ Milestone AV Technologies LLC (USA)

A frontrunner in Audio Video (AV) infrastructure and power with strong leading positions in high-value segments.

### ■ Server Technology (USA)

A leading provider of customer-driven and innovative power/access/control solutions for monitoring and managing critical IT assets for continual availability.

### ■ Starline (USA)

A worldwide provider of electrical power solutions for the data center, retail, healthcare, higher education and industrial markets.

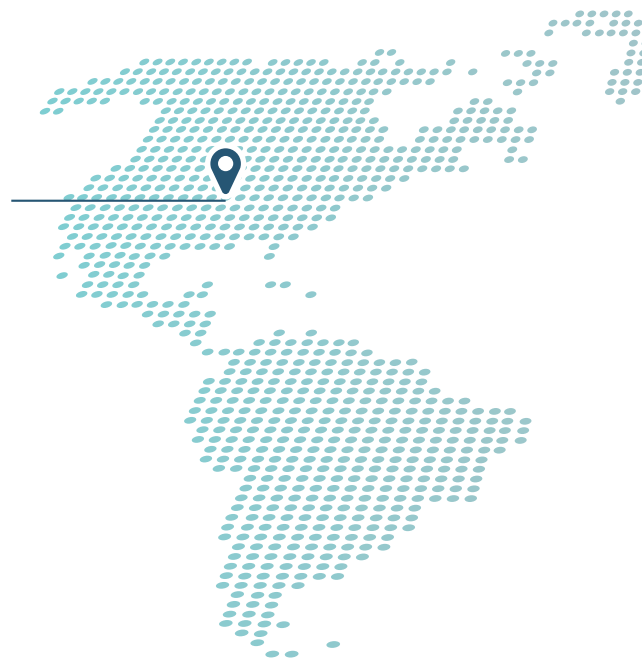

■ **Raritan** (USA)

A leading provider of intelligent rack PDUs, transforming how companies manage their data center power chains. The solutions increase the reliability and intelligence of data centers.

■ **Legrand** (France)

A global leader in network infrastructure solutions, especially with a broad range of copper and fiber connectivity, based on decades of experience. The Legrand product line features flexible, efficient solutions, united by superior design, to ensure that your data center or building network operates flawlessly.

■ **Minkels** (Netherlands)

A knowledge-driven producer and worldwide supplier of high-quality solutions for data center infrastructure, including racks and containment solutions.

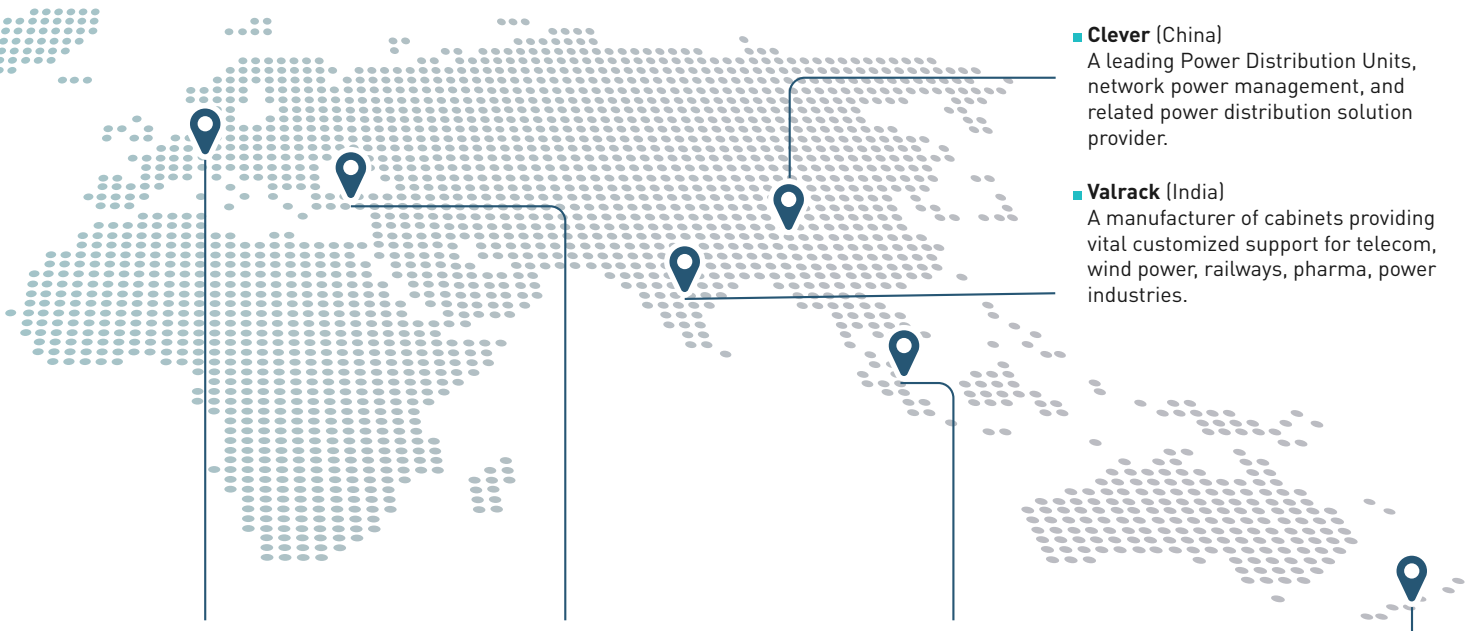

■ **Clever** (China)

A leading Power Distribution Units, network power management, and related power distribution solution provider.

■ **Valrack** (India)

A manufacturer of cabinets providing vital customized support for telecom, wind power, railways, pharma, power industries.

■ **Compose** (Netherlands)

A specialist for passive data communication solutions, relating to the cabling of data centers, buildings and fiber optic infrastructures (FTTx).

■ **Estap** (Turkey)

A manufacturer of enclosures and cabinets for data communication equipment.

■ **SJ Manufacturing** (Singapore)

A data center specialist on racks, containment and caging now promoted under Legrand brand.

■ **Geiger** (Germany)

With its 25-year success story, Geiger is able to provide customer value in the field of scalable and highly available communication and data center infrastructure from the idea to the implementation.

■ **Trical** (New Zealand)

A front-runner in electrical and digital enclosures and switchboards for residential and commercial buildings.

■ **Modulan** (Germany)

A provider of custom cabinets for data centers.

# An extensive expertise in digital infrastructures

Legrand's complete global solutions for data communication perfectly address the key challenges for digital networks: network performance, protection and accessibility of every infrastructure. Our LCS<sup>3</sup> system offers copper and fiber global solutions for structured cabling both in data center and LAN.

## LOCAL AREA NETWORKS



## DATA CENTER & SERVER ROOM



### SOLUTIONS FOR STRUCTURED CABLING

- **Housing solutions**  
(19" freestanding and wall-mounting cabinets, open racks, PDUs, micro data centers, etc.)
- **Copper solutions**  
(RJ45 connectors, patch panels, cables and patch cords, PoE switches, etc.)
- **Fiber solutions**  
(Connectors, equipped & modular panels, bend-insensitive cables, etc.)



### SOLUTIONS FOR STRUCTURED CABLING IN SERVER ROOMS

- **Housing solutions**  
(Server cabinets, aisle containment, cooling units and cold corridor, open racks, PDUs, etc.)
- **Copper solutions**  
(Preterminated, etc.)
- **Fiber solutions**  
(Preterminated, intelligent patching, high-density fiber optic solutions, etc.)





# LCS<sup>3</sup>

## AUDIO VIDEO SYSTEM



A WIDE RANGE OF TECHNOLOGIES TO SUIT THE LOCATION AND THE USER EQUIPMENT

- Racks and enclosures
- Preterminated audio/video sockets (HDMI, display port, USB, RCA, JACK, etc.)
- Cords and adaptors



## A GLOBAL OFFER REACHING ALL DIMENSIONS OF EXCELLENCE:

- Performance
- Scalability & Maintenance
- Efficiency
- Astuteness
- Flexibility
- Reliability & Safety



# LCS<sup>3</sup>

A GLOBAL  
OFFER

## Cabling system: Performance

Legrand's LCS<sup>3</sup> system offers you a complete range of copper solutions as well as fiber optic solutions designed to deliver advanced network performance:

- ▶ 25 Gbps and 40 Gbps Ethernet applications (Copper system)
- ▶ 40 Gbps, 100 Gbps and 400 Gbps Ethernet applications (Fiber optic system)
- ▶ MTP/MPO high density and up to Cat. 8 solutions (Copper and Fiber optic systems)



## COPPER SYSTEM

► CAT. 8 TRANSMISSION UP TO 40 GBPS

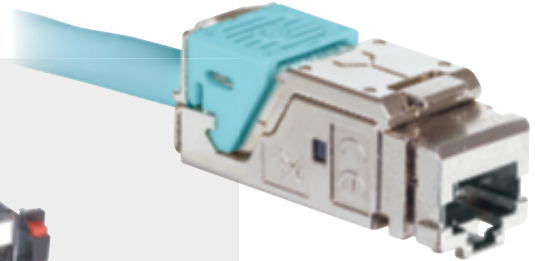
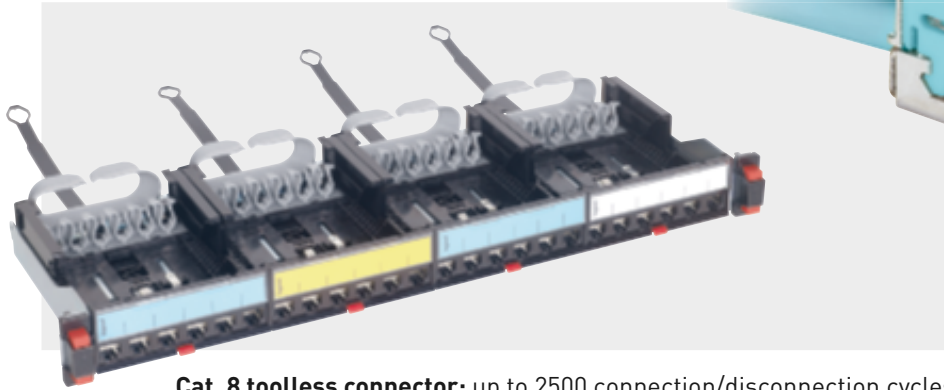

Cable & connector compliant with ISO/IEC 11801 standards

**Cat. 8 toolless connector:** up to 2500 connection/disconnection cycles

## FIBER OPTIC SYSTEM

► MTP/MPO SOLUTION TRANSMISSION UP TO 400 GBPS



High density connection with 12 or 24 fibers compliant with IEEE 802.3ba.

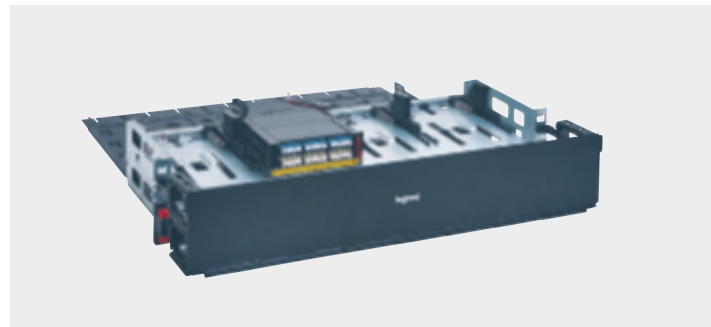

**MPO/MTP** fiber optic drawers. Up to 96 LC on 1U. Available in 1U, 2U and 4U.



Up to 144 LC on 1U. Available in 1U, 2U and 4U.

## COPPER SYSTEM OPTIMUM PERFORMANCE WITH CAT. 8

### CAT.8 CONNECTORS

The **toolless Cat. 8 STP** connectors with transmission speed (bit rate) from 25 Gbps to 40 Gbps, are integral to the performance of the LCS<sup>3</sup> system.

- In accordance with ISO/IEC 11801 series standards
- Tested up to 2500 connection/disconnection cycles
- A perfect connection in just a few seconds

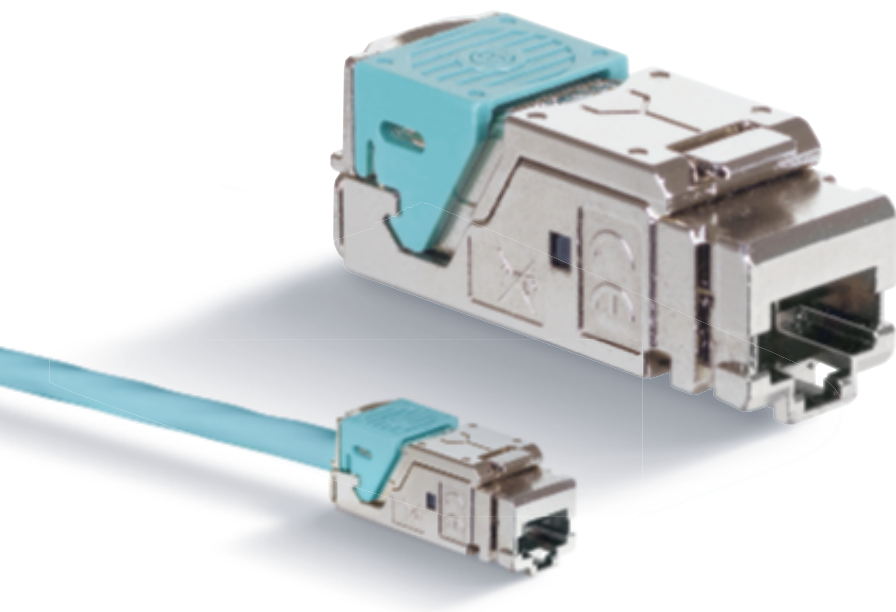

PATENTED  
DESIGN

### CONNECTION & CABLING

**To maximize performance, combine the Legrand Cat. 8 connector together with the Legrand Cat. 8 cable supporting up to 40 Gbps over a single cable.**

The Cat. 8 cable is terminated with an improved dedicated RJ45 connector which can support future performance.

The performance is 4 times better than that of a Cat. 6A cable with up to 2000 MHz bandwidth.

- Double screening to avoid interference and loss of data
- Dedicated to higher capacity in data centers and equipment rooms
- Compliant with ISO/IEC 11801 series standards

Legrand guarantees the following performance on end-to-end links of Cat. 6A/Class EA:  
**3dB margin on Channels, on Return Loss (RL) and Near End Cross Talk (NEXT) performance, for the complete frequency range, based on ISO/IEC limits.**

- No marginal results (shown with Asterisk on test results) on Permanent Links
- Valid on standard compliant 2 connectors channels

### NEXT

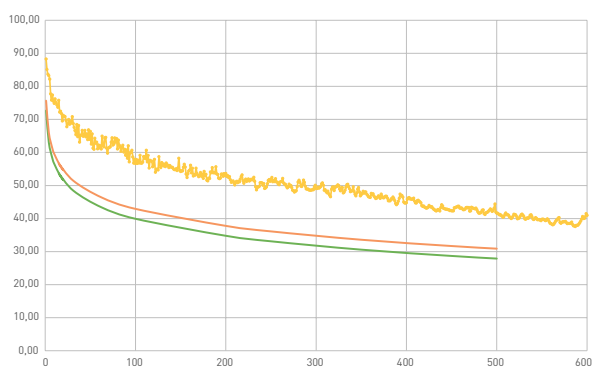

■ Standard limit ■ LCS³ Guarantee ■ LCS³ Typical NEXT

### RETURN LOSS

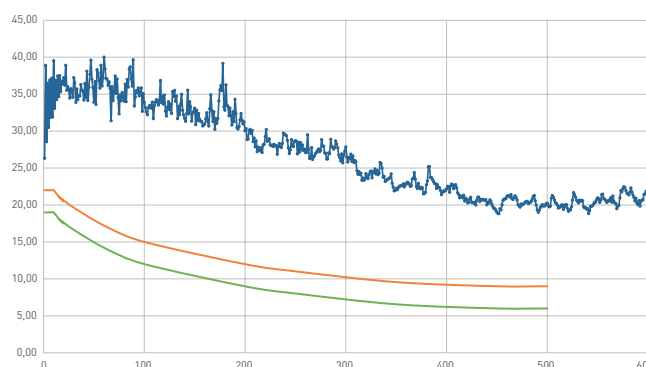

■ Standard limit ■ LCS³ Guarantee ■ LCS³ Typical RL

### APPLICATIONS DISTANCES ACCORDING TO CATEGORY OF CABLING

|                          | LCS³<br>Cat.5e          | LCS³<br>Cat.6           | LCS³<br>Cat.6A          | LCS³<br>Cat.8 |
|--------------------------|-------------------------|-------------------------|-------------------------|---------------|
| Frequency <sup>(1)</sup> | 100MHz                  | 250MHz                  | 500MHz                  | 2000MHz       |
| Application              |                         |                         |                         |               |
| 1000Base-T               | 100m                    | 100m                    | 100m                    | 100m          |
| 2.5Gbase-T               | Possible <sup>(2)</sup> | Possible <sup>(2)</sup> | 100m                    | 100m          |
| 5Gbase-T                 | Possible <sup>(2)</sup> | Possible <sup>(2)</sup> | 100m                    | 100m          |
| 10Gbase-T                | N/A <sup>(4)</sup>      | Possible <sup>(3)</sup> | 100m                    | 100m          |
| 25Gbase-T                | N/A <sup>(4)</sup>      | N/A <sup>(4)</sup>      | Possible <sup>(5)</sup> | 30m           |
| 40Gbase-T                | N/A <sup>(4)</sup>      | N/A <sup>(4)</sup>      | Possible <sup>(5)</sup> | 30m           |

<sup>(1)</sup> Maximum frequency defined in the standards

<sup>(2)</sup> Follow ISO/IEC TR 11801-9904 or TIA TSB 5021 to evaluate possibility on installed links. Distance will depend on many factors.

<sup>(3)</sup> Follow ISO/IEC TR 24750 or TIA TSB 155-A to evaluate possibility on installed links. Distance will depend on many factors.

<sup>(4)</sup> Not Available.

<sup>(5)</sup> Follow ISO/IEC TR 11801-9905 to evaluate possibility on installed links. Distance will depend on many factors.

## COPPER SYSTEM PoE CERTIFICATION

Using PoE technology, devices such as Wi-Fi access points, cameras, etc. can be supplied with power by the Ethernet data cable. The cable combines data and power to supply all the PoE peripherals.

**The LCS<sup>3</sup> connectors are PoE++ Third Party certified.**

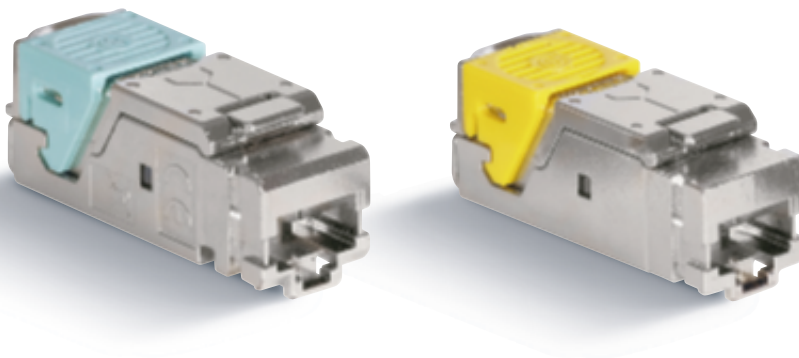

**TABLE OF PoE TYPES ACCORDING TO CABLING REQUIREMENTS AND POWER AVAILABILITY**

| Name (Common name)                         | Type 1 (PoE)             | Type 2 (PoE+)            | Type 3 (PoE++)                                       | Type 4 (PoE++)                                       |
|--|--------------------------|--------------------------|--|--|
| IEEE Standard                              | 802.3af (2003)           | 802.3at (2009)           | 802.3bt (2018)                                       | 802.3bt (2018)                                       |
| Minimum Category Required                  | Category 3               | Category 5e              | Category 5e  | Category 5e  |
| Number of Pairs for Power                  | 2                        | 2                        | 2 or 4   | 4  |
| Maximum Current per Pair                   | 350 mA                   | 600 mA                   | 600 mA   | 960 mA   |
| Guaranteed maximum Power at PSE Output     | 15.4 W                   | 30.0 W                   | 60.0 W   | 90.0 W   |
| Guaranteed maximum Power at PE Input       | 13 W                     | 25.5 W                   | 51.0 W   | 71.3 W   |
| Diagram with maximum current per wire (mA) | 175<br>175<br>175<br>175 | 300<br>300<br>300<br>300 | 300<br>300<br>300<br>300<br>300<br>300<br>300<br>300 | 480<br>480<br>480<br>480<br>480<br>480<br>480<br>480 |

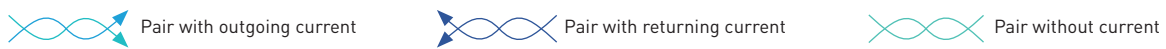

There are subdivisions of PoE called Classes. Below is a table of these Classes with correspondence to the PoE Types and the power available. It's important to note that the difference of power between the PD and the PSE does not represent an average efficiency, but only a worst case with maximum distance and highest resistance cabling.

| Class                                | 1      | 2   | 3      | 4    | 5                     | 6    | 7                     | 8    |
|--------------------------------------|--------|-----|--------|------|-----------------------|------|-----------------------|------|
| Type                                 | Type 1 |     | Type 2 |      | Type 3 <sup>(1)</sup> |      | Type 4 <sup>(2)</sup> |      |
| PSE maximum output average power (W) | 4      | 7   | 15.4   | 30   | 45                    | 60   | 75                    | 90   |
| PD Input Average Power (W)           | 3.8    | 6.5 | 13.0   | 25.5 | 40.0                  | 51.0 | 62.0                  | 71.3 |
| PD Peak operating Power (P)          | 5.0    | 8.4 | 14.4   | 28.3 | 42.0                  | 53.5 | 65.1                  | 74.9 |

Notes: <sup>(1)</sup> Type 3 can also support Classes 1 to 4. <sup>(2)</sup> Only single signature PD shown

## COMMITMENTS ON PoE

Legrand solutions are complying as per below:

- Cables: 802.3 bt PoE++ applications compatible according to installation standards ISO/IEC 14763-2 and EN 50174-2:2018.
- Connectors: compatible remote powering "PoE" up to 100 W (IEEE 802.3af, IEEE 802.3at, IEEE 802.3bt). Third party certified IEC 60512-99-002 for disconnection under PoE Type 4.
- Patch cords: compatible remote powering "PoE" up to 100 W (IEEE 802.3af, IEEE 802.3at, IEEE 802.3bt) when installed according to standards ISO/IEC 14763-2 and/or EN 50174-2:2018

Confident in the design and quality of our solutions, we overperform and guarantee the full 90m Permanent Link\* under PoE maximum power of 90W for shielded LCS<sup>3</sup> systems. Our PoE guide provides clear installation conditions and allows Legrand to give a 25-year warranty on applications including PoE.

\*With 2m cord in the technical room and 5m cord at user side. Contact us for other configurations.



## QUALITY & PROTECTION

Due to the high power in PoE++, the choice of a high-quality connector is essential. While disconnected, Legrand's high-quality connectors prevent damage to the contacts due to the arc generated.

**WANT TO KNOW MORE ABOUT PoE AND INCREASE THE POWER OF YOUR NETWORK?**



▶ **CONTACT YOUR LOCAL SALES REP TO GET OUR PoE INSTALLATION GUIDES!**

# FIBER OPTIC SYSTEM LEGRAND'S MTP SYSTEM

## HIGH-SPEED SOLUTION

With data centers, increased data rates have become priority requirement. The IEEE has introduced parallel optics as an alternative to higher bandwidth fiber, starting with 40Gbps and now reaching 800Gbps Ethernet.

To answer this need Legrand has introduced the MTP (Multiple-Fiber Push-On/Pull-Off compatible MPO) fiber solution to the catalogue. It guarantees speed, resistance, high performance and high density.

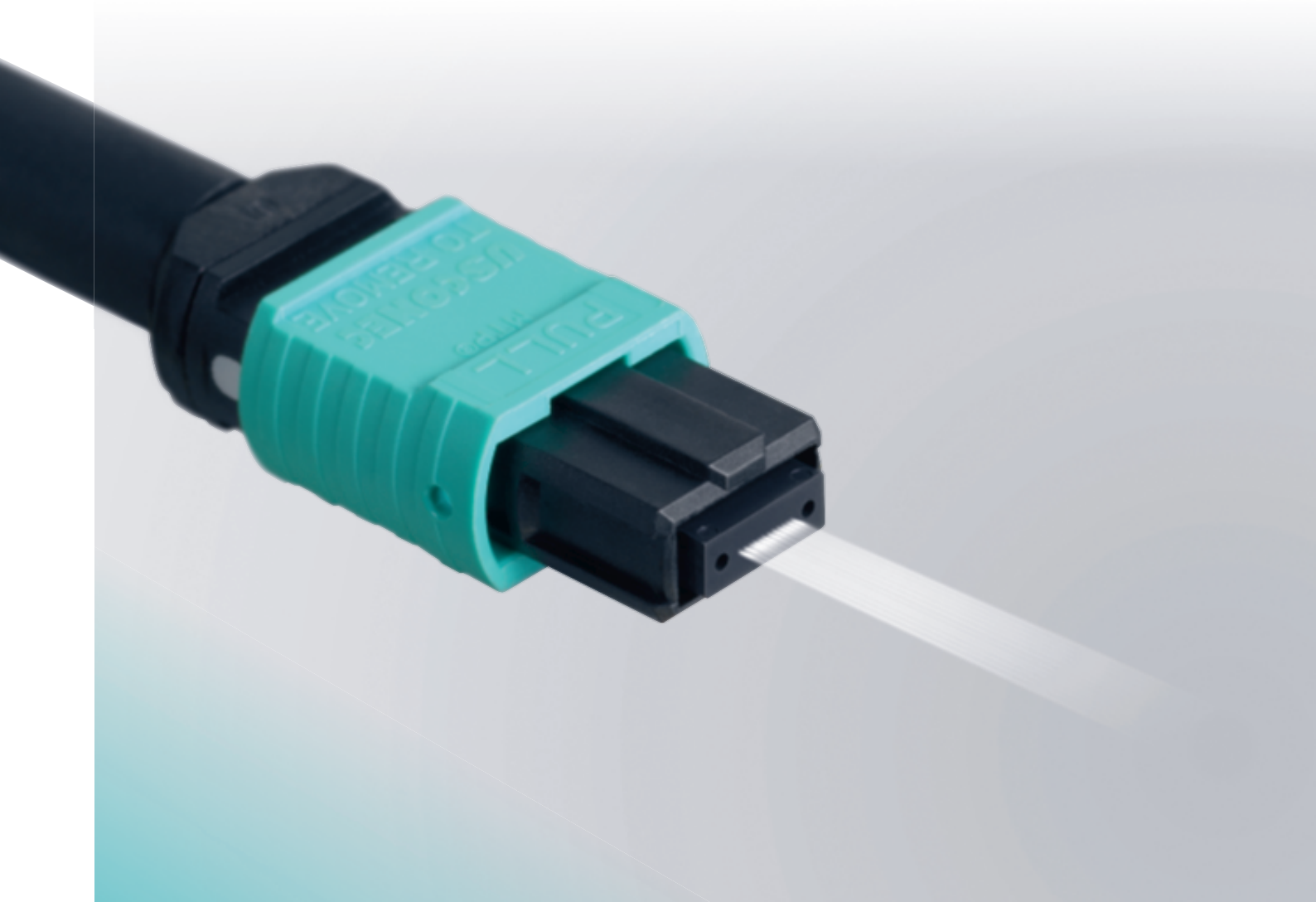



## 40/100/400 GIGABIT ETHERNET CONNECTIVITY AND CABLE

Identified by IEEE, TIA and ISO/IEC as the solution for non-duplex applications. The term MPO is the generic name while the term MTP is a specific higher performance version with lower insertion loss.

MTP connector features:

- a high-speed connection with 12 fibers (2x12 for 24 fibers and with cassettes 8 fibers compatible)
- precise and safe connection
- optimized cable management
- high-density fibers
- scalable system for future upgrades
- simple maintenance operations
- ease of extraction. No complex installation on site - plug and play
- the MTP is a multi-core connector. 1 cable = 1 connector



### WITH STANDARD ACTIVE EQUIPMENT, WE NEED TO CONVERT THE MTP TO LC OR SC

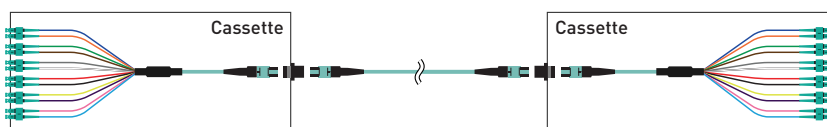

### OPTICAL PERFORMANCE

| MTP® connectors                    | Multimode Ultra Performance*   | Single-mode Ultra Performance*   |
|------------------------------------|--|--|
| IL/Master                          | 0.1 dB typical (all fibers)<br>0.35 dB maximum (single fiber) <sup>(2) (3)</sup> | 0.1 dB typical (all fibers)<br>0.35 dB maximum (single fiber) <sup>(1) (4)</sup> |
| IL Max/Random*                     | 0.35 dB (single fiber)   | 0.35 dB (single fiber)   |
| Optical return loss <sup>(5)</sup> | > 20 dB  | > 60 dB (8° angle-polished)  |

<sup>(1)</sup> As tested in accordance with ANSI/TIA-455-171 Method D3 / IEC 61300-3-4

<sup>(2)</sup> As tested in accordance with ANSI/TIA-455-171 Method D1 / IEC 61300-3-4

<sup>(3)</sup> As tested on 50µm fibers at a wavelength of 850 nm in accordance with IEC 61280-4-1

<sup>(4)</sup> Complies with IEC 61755-3-31/GRADE B

<sup>(5)</sup> As tested in accordance with IEC 61300-3-6 and ANSI/TIA-455-107A

\* Performance is guaranteed only with other components of the same Legrand range (Core, Ultra and Quantum). Mixing ranges or use of components of other brand may lead to a different performance of the system. The uncertainty value for field measurement with LSPM testing using a reference cord defined in ISO/IEC 14763-3 applies to field testing with proposed Legrand testing cords. Refer to the Fiber Optic Testing Guide for Legrand Solutions.

| LC, SC, LC APC, SC APC connectors | Multimode Ultra Performance* | Single-mode Ultra Performance* |
|-----------------------------------|------------------------------|--------------------------------|
| IL Max/Master*                    | 0.15 dB                      | 0.15 dB                        |
| IL Max/Random** ***               | 0.2 dB                       | 0.25 dB                        |
| Typ. IL/Master*                   | 0.08 dB                      | 0.12 dB                        |
| Typ. IL/Random** ***              | 0.10 dB                      | 0.12 dB                        |
| Return loss (UPC/APC)             | > 25 dB                      | > 55/65 dB                     |

\* IEC 61300-3-4

\*\* IEC 61300-3-34

\*\*\* Performance is guaranteed only with other components of the same Legrand range (Core, Ultra and Quantum). Mixing ranges or use of components of other brand may lead to a different performance of the system. The uncertainty value for field measurement with LSPM testing using a reference cord defined in ISO/IEC 14763-3 applies to field testing with proposed Legrand testing cords. Refer to the Fiber Optic Testing Guide for Legrand Solutions.

### COMMON DATA CENTER APPROACHES

Multimode fiber systems have been the most cost-effective fiber solution to use in the data center because the transceivers are much less costly than single-mode transceivers. Multimode transceivers use a vertical cavity surface emitting laser (VCSEL) light source, which is easy to manufacture and package. Multimode fiber systems have a shorter reach than single-mode systems, however surveys have shown that more than 80% of data centers links extend to 100m or less. Although single-mode cable is less expensive, after factoring in the total system cost of multimode versus single-mode, multimode is still far more cost efficient.

### MAXIMUM DATA RATE ACCORDING TO FIBER TYPE AND NUMBER OF CORES USED

|                | OM3   | OM4  | OM5  | OS1a  | OS2  |
|----------------|---|--|--|---|--|
| <b>2-core</b>  | 1Gbps: 550m<br>10Gbps: 300m<br>25Gbps: 70m<br>50Gbps: 70m     | 1Gbps: 550m<br>10Gbps: 400m<br>25Gbps: 100m<br>50Gbps: 100m<br>100Gbps: 100m | 1Gbps: 550m<br>10Gbps: 400m<br>25Gbps: 100m<br>50Gbps: 100m<br>100Gbps: 100m | 1Gbps to<br>400Gbps: 2km                        | 1Gbps: 5km<br>10Gbps to<br>400Gbps: 10km       |
| <b>4-core</b>  | 100Gbps: 70m  | 100Gbps: 100m<br>200Gbps: 100m   | 100Gbps: 100m<br>200Gbps: 100m   | 100Gbps: 500m                                   | 100Gbps: 500m                                  |
| <b>8-core</b>  | 40Gbps: 100m<br>100Gbps: 70m<br>200Gbps: 70m<br>400Gbps: 100m | 40Gbps: 150m<br>100Gbps: 100m<br>200Gbps: 100m<br>400Gbps: 100m              | 40Gbps: 150m<br>100Gbps: 100m<br>200Gbps: 100m<br>400Gbps: 150m              | 200Gbps: 500m<br>400Gbps: 500m<br>800Gbps: 500m | 200Gbps: 500m<br>400Gbps: 500m<br>800Gbps: 2km |
| <b>16-core</b> | 400Gbps: 100m<br>800Gbps: 70m                                 | 400Gbps: 100m<br>800Gbps: 100m   | 400Gbps: 100m<br>800Gbps: 100m   | 800Gbps: 100m<br>1.6Tbps: 500m                  | 800Gbps: 2km<br>1.6Tbps: 2km                   |

Data in orange: draft applications (distances may vary at time of publication)

## HIGH PERFORMANCE ON ALL STANDARD AND ON-DEMAND PRETERMINATED SYSTEMS

| Connectivity   | TYPES  |            |  |           |   |                            |   |                     |
|--|--|------------|--|-----------|---|----------------------------|---|---------------------|
| Trunks   | Tight buffer   | Loose tube | Loose tube<br>corrugated<br>steel tape                                   | Break-out | Fan-out   | Micro-cable<br>250 microns | Cassette  | Cassette<br>Fan-out |
|  |  |            |  |           |   |                            |   |                     |
| <b>TYPE OF FIBER</b><br>OS1/OS2, OM1,<br>OM2, OM3, OM4,<br>OM5, etc. |  |            | <b>NUMBER OF FIBERS</b><br>2, 4, 6, 8, 12, 16, 24,<br>On demand,<br>etc. |           | <b>CHOICE OF<br/>TERMINATION</b><br>LC, SC, SC APC, MTP<br>etc. |                            | <b>PLEASE CONTACT US</b><br>for any specific<br>requirements. |                     |
| Cabling  | High density (HD)  |            |  |           | Ultra high density (UHD)  |                            |   |                     |
| Panels & cassettes<br>Splice panel                                   | <b>MTP to LC or SC. Cassette to cassette without MTP</b> |            |  |           | <b>MTP to LC</b>  |                            |   |                     |
|  |  |            |  |           |   |                            |   |                     |
| Cables/Patch cords   | OM2, OM3, OM4, OM5 & OS2<br>Microcable loose tube        |            |  |           |   |                            |   |                     |

# LCS<sup>3</sup>

A GLOBAL  
OFFER

## Cabling system

# Scalability & Maintenance

Legrand's LCS<sup>3</sup> range offers you innovative systems to facilitate wiring and installation, while offering increased data rates with both the copper solution and the fiber optic solution.

PATENTED  
DESIGN

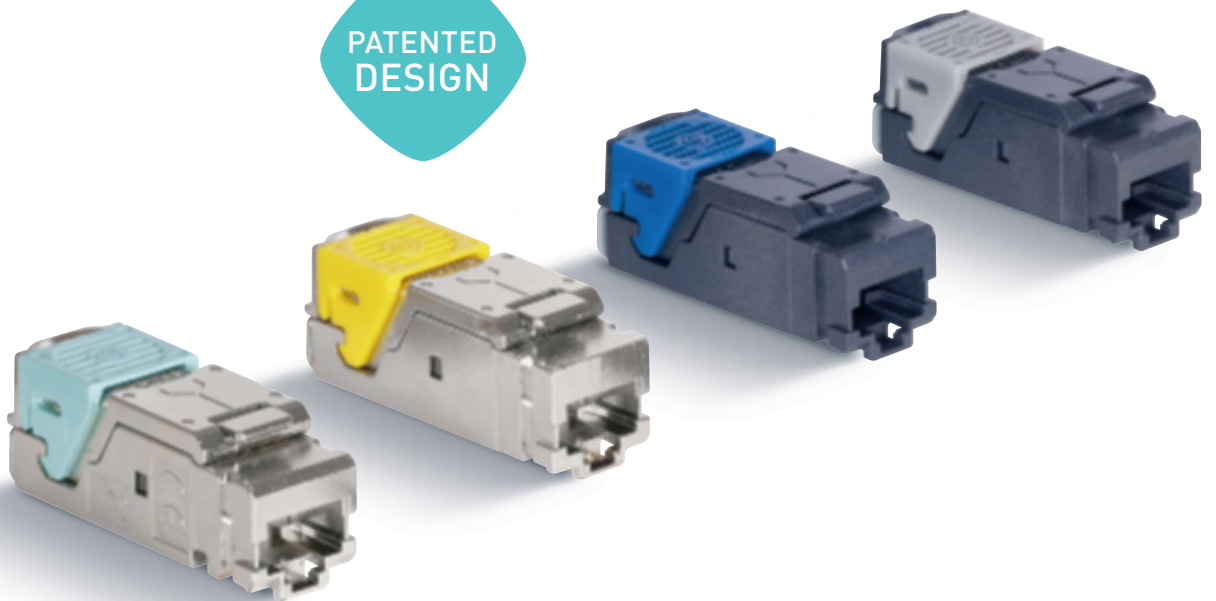

## COPPER SYSTEM RJ45 CONNECTORS

The **TOOLLESS CONNECTORS** with toolless fast connection are available in all categories for installation both on patch panels and in the workstation. A perfect connection can be obtained in a few seconds, guaranteeing optimum performance of the link from the patch panel to the workstation.

The toolless connectors are colour-coded so their category can be safely identified:

- Cat. 8: aqua
- Cat. 6A: yellow
- Cat. 6: blue
- Cat. 5e: grey

## TOOLLESS CONNECTOR CONNECTION PHASES

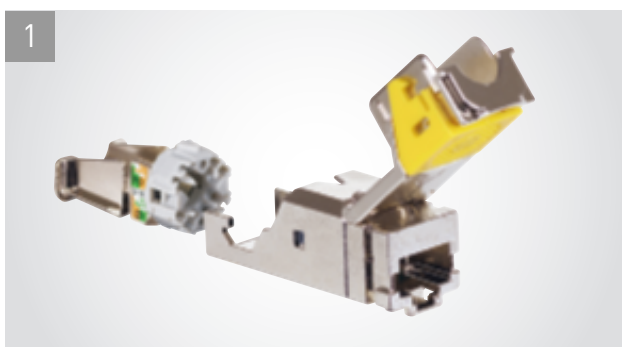

1 Take the wire housing

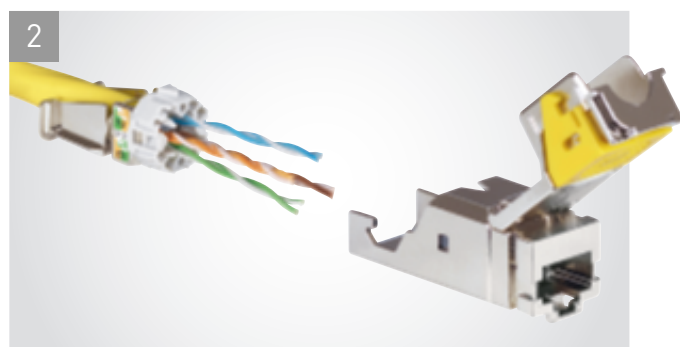

2 Pass the cable through the back of the wire housing

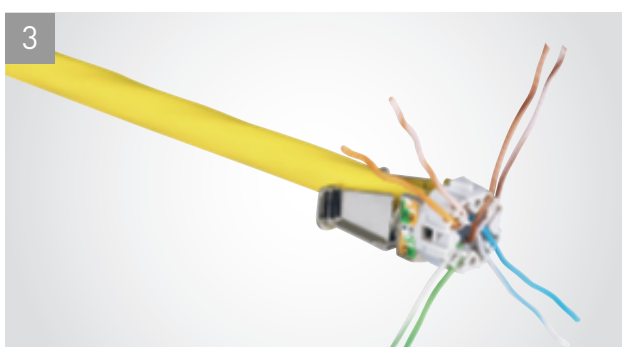

3 Separate and insert the pairs

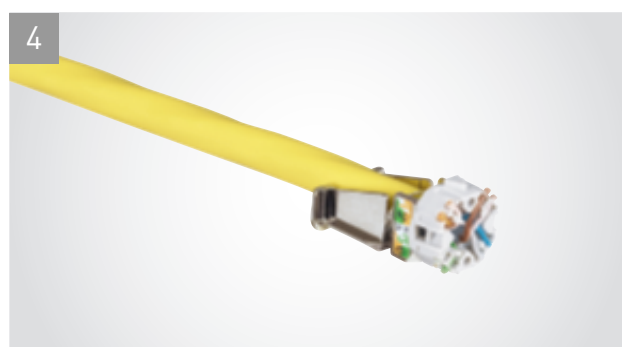

4 Cut the pairs

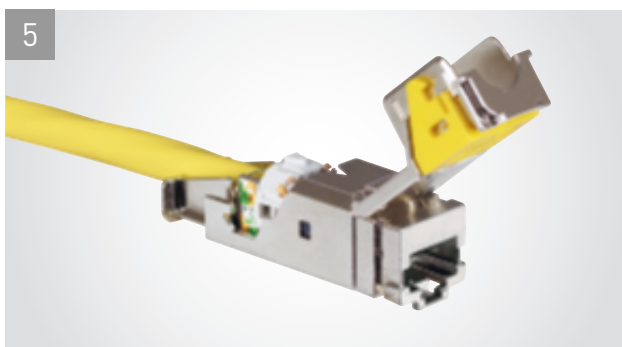

5 Install the wire housing without pushing



6 Push down the lever and lock the connector

## COPPER SYSTEM PATCH PANELS

The patch panels have been designed and produced to optimize space, with up to 48 ports per unit and make maintenance and future upgrades easier.

They are available in both flat and angled versions.

They have a quick system for pulling out the unit and an innovative cable guiding system for tidy and easy cable management.

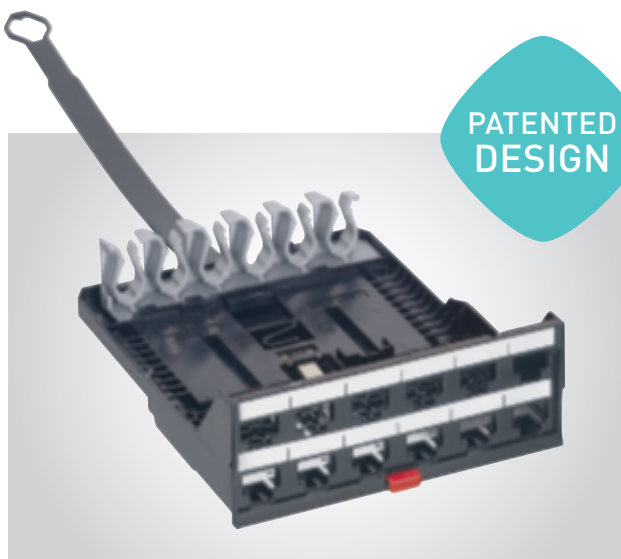

Block of 12 connectors for patch panel

### INNOVATIVE CASSETTES

- Sliding cassettes: easier maintenance
- Fast push-button extraction
- Innovative modular cassette system
- Easy maintenance: hands free solution, cassette maintained after extraction
- **Easy to mix with Legrand fiber optic solutions**

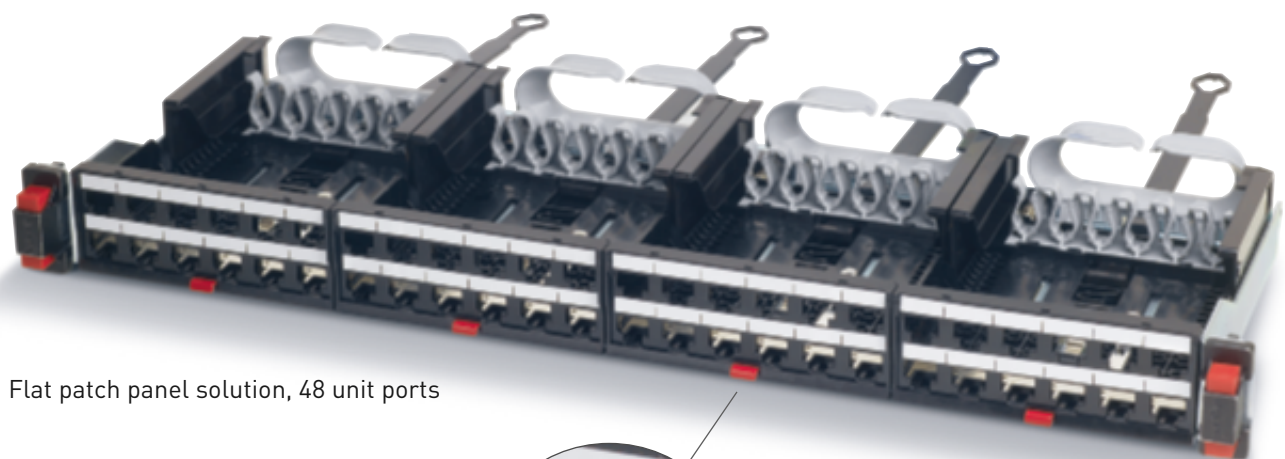

Flat patch panel solution, 48 unit ports



Fast push-button extraction



PATENTED DESIGN

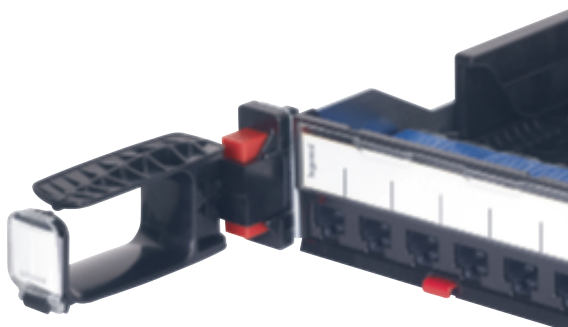
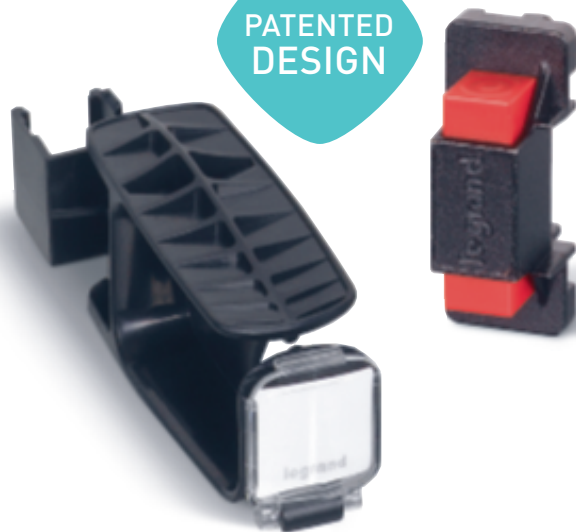

### QUICK-FIX SYSTEM

Innovative quick-fixing solution:

- Push and connect system
- Automatic earth connection
- In-rack cabling optimized
- Accessory for patch cords with rotating system for angle adjustment and label holder

**Compatible with all panels (flat, angled, HD)**

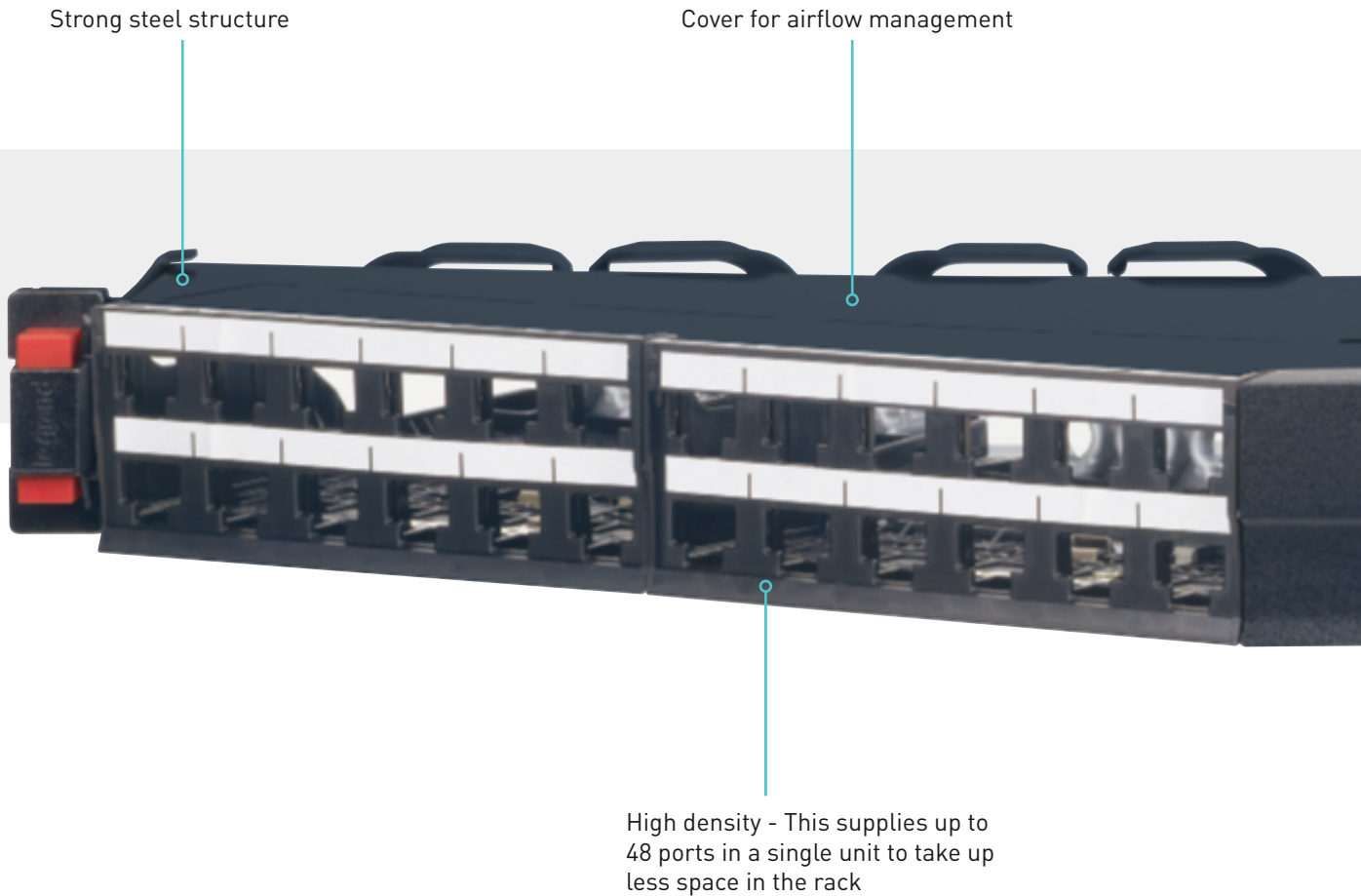

## ANGLED PATCH PANEL SOLUTION FROM 24 TO 48 PORTS PER UNIT

Patch panels with an angled design which allows the cable to run into each side of the rack, creating a correct cable radius of curvature.

This avoids the need to manage the cables horizontally, and allows the patch cords to be carried directly in the vertical cavities.

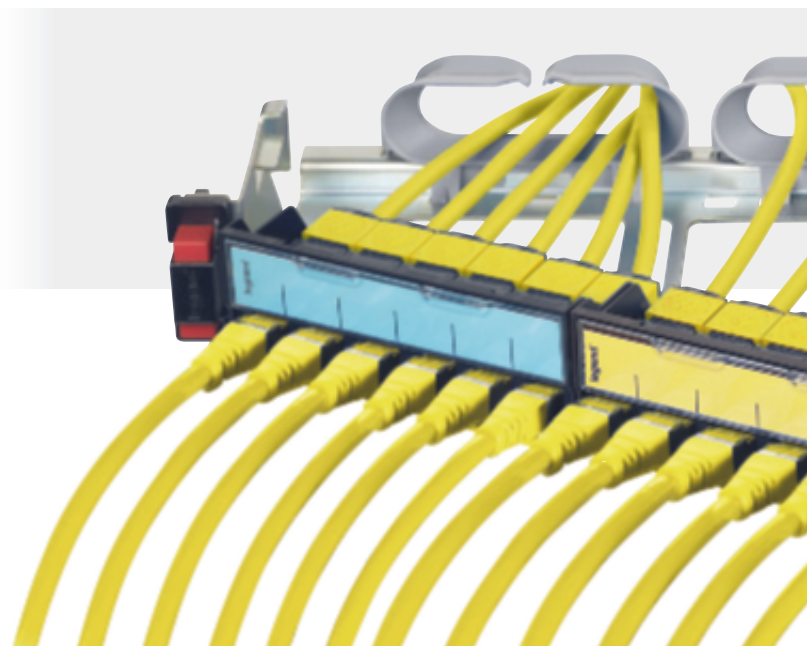



Tidy cable management

Quick-fix system

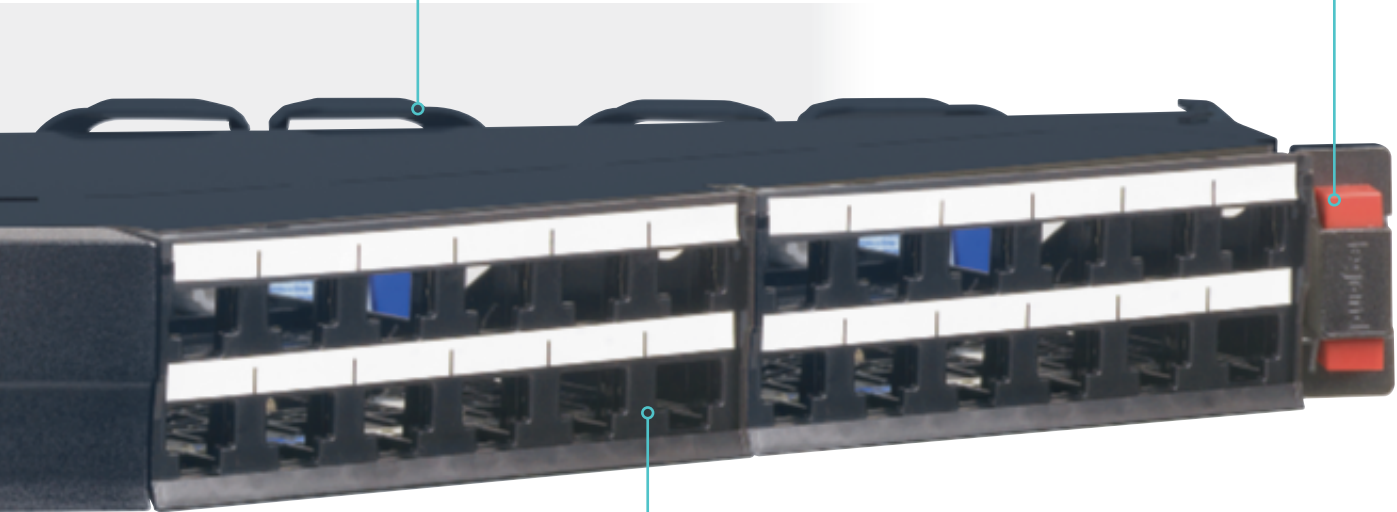

Simple and efficient  
identification of the ports

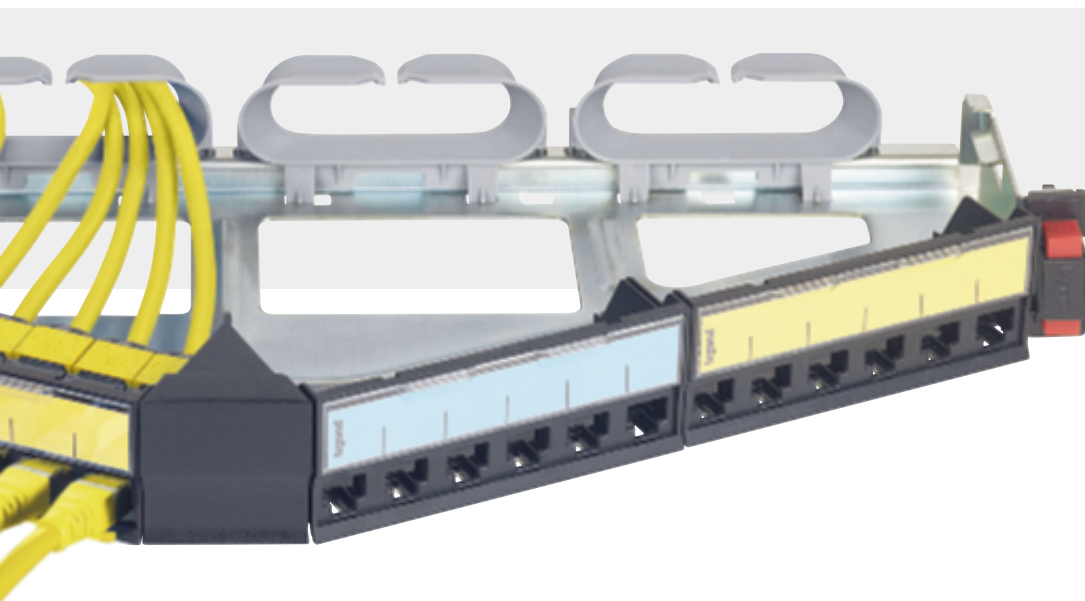

Also available  
in the 24-port version

## COPPER SYSTEM LCS<sup>3</sup> SERIES HDJ SYSTEM / NORTH AMERICAN SPECIFICATION COMPLIANCE

A global answer for global Customers Accounts:

- HD Jack RJ45 connectors
- LCS<sup>3</sup> patch panel and cassettes (6-port and 12-port)

### RJ 45 CONNECTORS

- Premium High-Density Jack (HDJ) from Cat. 5e to Cat. 6A
- ETL verified to TIA Category 5e, 6 and 6A component specification. Rear-loading, 180° exit, 8-position
- Quick and easy lacing cap termination
- Available all shielded for STP and different colours for UTP:
  - Cat. 5e: dark grey ■
  - Cat. 6: blue/white/yellow/black ■ ■ ■ ■
  - Cat. 6A: blue/yellow/black ■ ■ ■
- These products have earned the UL Listed Mark

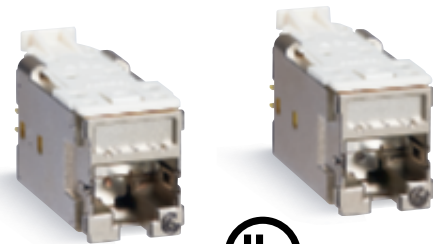

### PATCH PANELS

- Available with up to 48 ports per unit
- Make maintenance and future upgrades easier
- Available in flat versions: present the same quick system for pulling out the unit and an innovative cable guiding
- These products have earned the UL Listed Mark

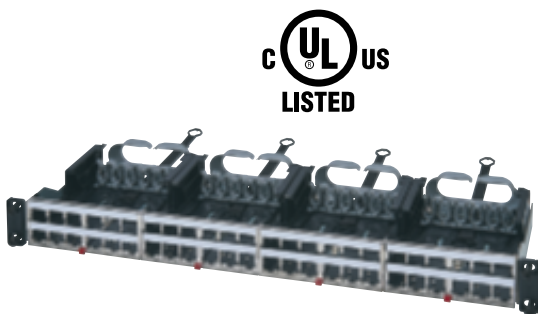

### STYLISH AND INNOVATIVE CASSETTES

- Sliding cassettes: easier maintenance
- Fast push-button extraction
- Innovative modular cassette system
- Easy maintenance: hands free, cassette maintained after extraction
- Easy to mix with Legrand fiber modules (HDFM)
- These products have earned the UL Listed Mark

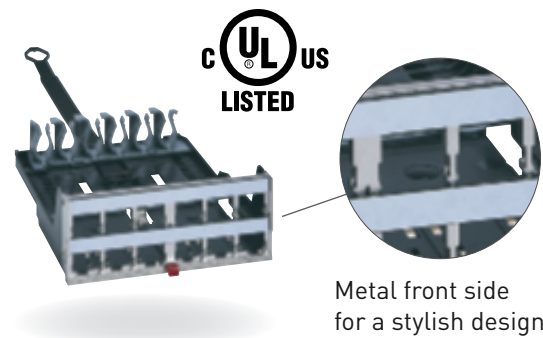

Metal front side for a stylish design

# FIBER OPTIC SYSTEM MEET-ME ROOM SOLUTIONS

## COMBINING HIGH DENSITY AND HIGH QUALITY

An ever-increasing number of data centers are being used, and at ever higher bandwidths, to meet the growing demand for computing capacity. And whether it's a regional data center, a colocation data center or a hyperscaler, access to the outside world and therefore fiber connectivity is vital for this.

The Legrand LCS<sup>3</sup> Meet-Me Room portfolio offers a fully scalable solution that seamlessly responds to both the high fiber numbers used in this type of environment and the high quality and reliability that comes with it.

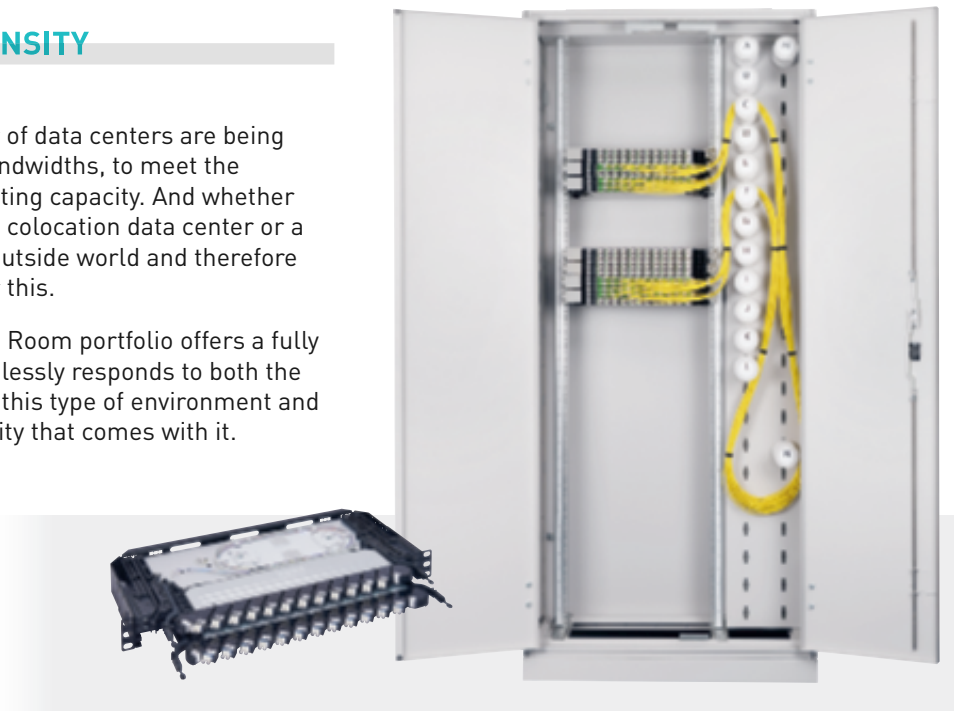

The innovative concept also offers the possibility of adding extra functionalities where necessary, such as WDM Mux/Dmux or PON integration. With this, the concept also offers excellent application possibilities in so called Telco environments or for example on-premise connectivity.

### TYPICAL DEPLOYMENT OPTIONS LEGRAND MEET-ME ROOM PORTFOLIO

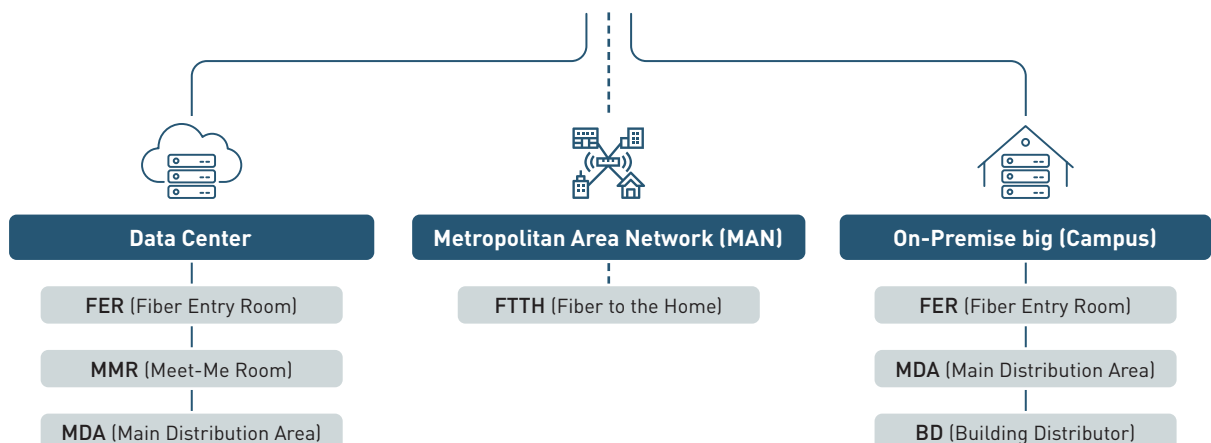

## OPTIMIZED AND SIMPLIFIED PATCHING

A good network does not only stand or fall with a good connectivity solution, also all preconditions have to be fulfilled correctly. The Legrand Meet-Me Room portfolio therefore consists of an Optical Distribution Frame (ODF) with optimized patch management, especially designed for high density applications. Even with more than 4,000 patches in an ODF frame, this allows the patches to be ranked in a structured way.

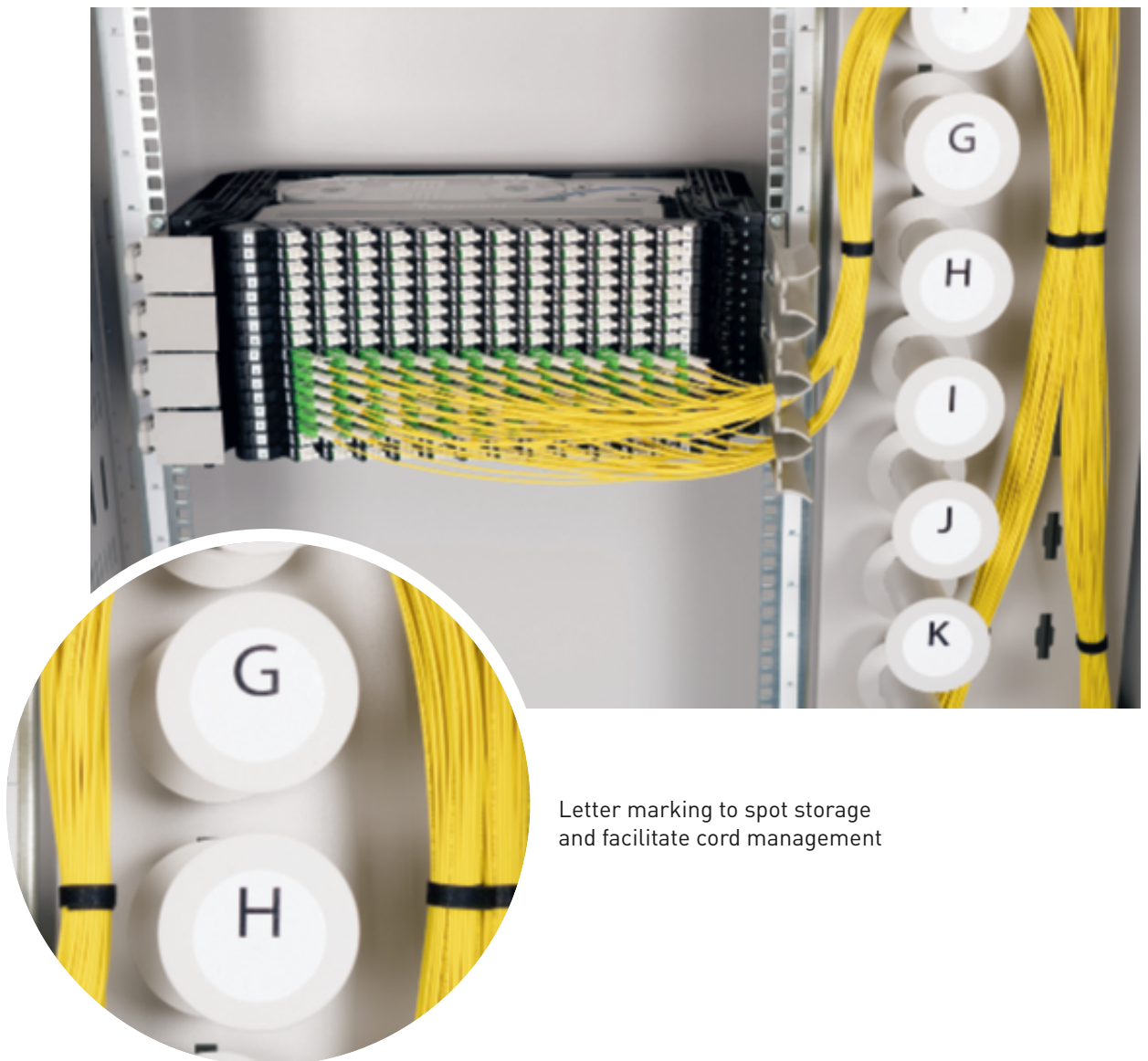

Letter marking to spot storage and facilitate cord management

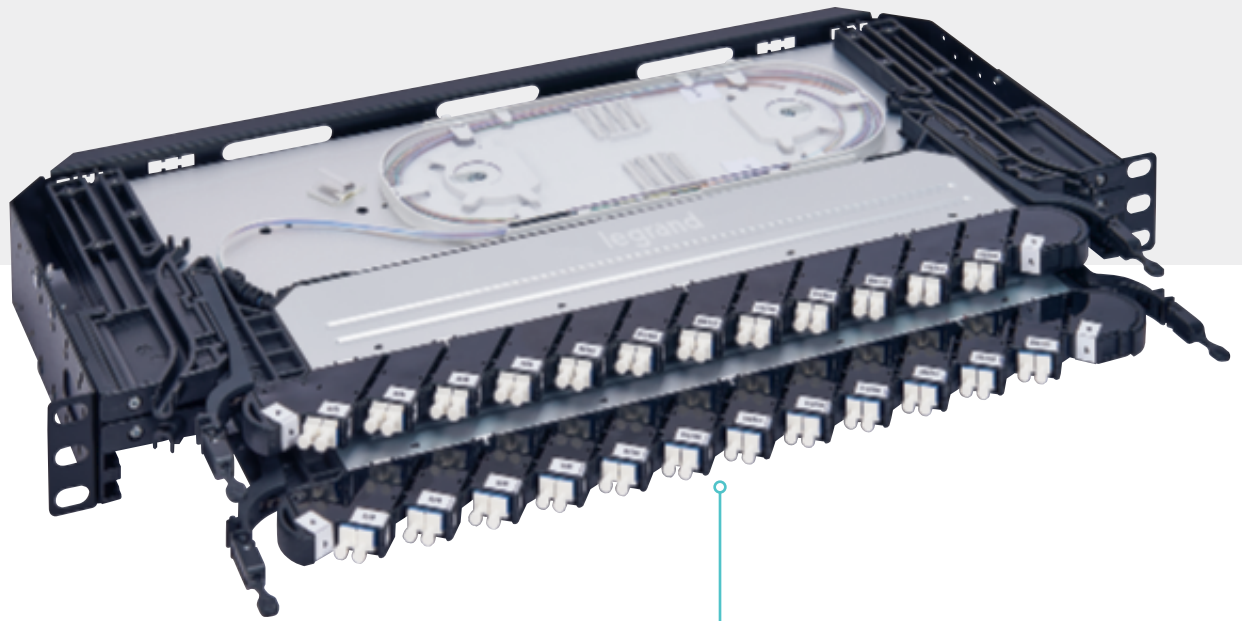

In order to simplify patching, the Meet-Me Room ODF patch panels are equipped with a slide-forward function, which makes the patch surface easily accessible, even in case of full patching.

A unique advantage of the Meet-Me Room patch panel is the ability to use it fully front loaded. Patch cabling and incoming cabling are fed in from the front, separated from each other, so that moves, adds and changes are easy to perform.



## FIBER OPTIC SYSTEM CREATING FULL HD SYSTEMS

Legrand boosts its high density offer for building networks and data center applications within LCS<sup>3</sup> fiber systems. From 1U to 4U, they support the fiber and equipment port density required for all networks with high and even ultra high density.

Base 12, MTP(F) to MTP(F),  
Type B, OM4 trunk in Fiber  
raceway system\*

### 4U HD panel

Cat.No 0 321 77

Can hold 32 slim cassettes  
(into 16 supports) and/or MTP,  
splice fiber, copper cassettes

### Slim multimode OM4 cassettes

Cat.No 0 321 69

12 fibers, MTP(M)-LC duplex,  
universal polarity  
To be connected with OM4  
duplex LC patch cord, A-B\*

### Support for slim cassettes

Cat.No 0 321 38

Can take up to 2 slim cassettes  
12 fibers, MTP(M)-LC duplex,  
universal polarity

NEAR END

\* Configured offer possible on request

**1U HD panel**

Cat.No 0 321 75  
Can hold 8 slim cassettes  
(into 4 supports) and/or MTP,  
splice fiber, copper cassettes

**Slim multimode OM4 cassettes**

Cat.No 0 321 69  
12 fibers, MTP(M)-LC duplex,  
universal polarity  
To be connected with OM4 duplex  
LC patch cord, A-B\*

**Support for slim cassettes**

Cat.No 0 321 38  
Can take up to 2 slim cassettes  
12 fibers, MTP(M)-LC duplex,  
universal polarity

FAR END

## FIBER OPTIC SYSTEM HIGH DENSITY MODULAR PANELS

### FROM 1U TO 4U

Optimize space and connectivity with our three HD modular panels! These quick-fixing solutions (automatic mounting and automatic grounding on 19" uprights) offer you optimum capacities per U: 96 in LC version, 48 in SC version and 24 in ST version! Keeping link connections accessible and manageable, they offer slim and mix-media cassettes.

#### 4U HIGH DENSITY PANEL

Can hold up to 32 slim cassettes (into 16 supports)

Rear management accessories to suit all configurations: fan out, cable glands, copper

Possibility to mix fiber and copper cassettes in one panel

Each panel can be equipped with both standard and slim High Density cassettes

Quick fixing solutions on all the versions from 1U to 4U

Cord management system (except for the 1U panel, to be equipped with Cat.No 0 321 78) with front, side and bottom protection of the patchcords, preventing any risk of damage

Labeling system for easy identification

Equipped with the new-generation Quick-fix system for automatic (screwless) mounting on racks or cabinet uprights

Integrated front door for protection against intrusive patching and laser

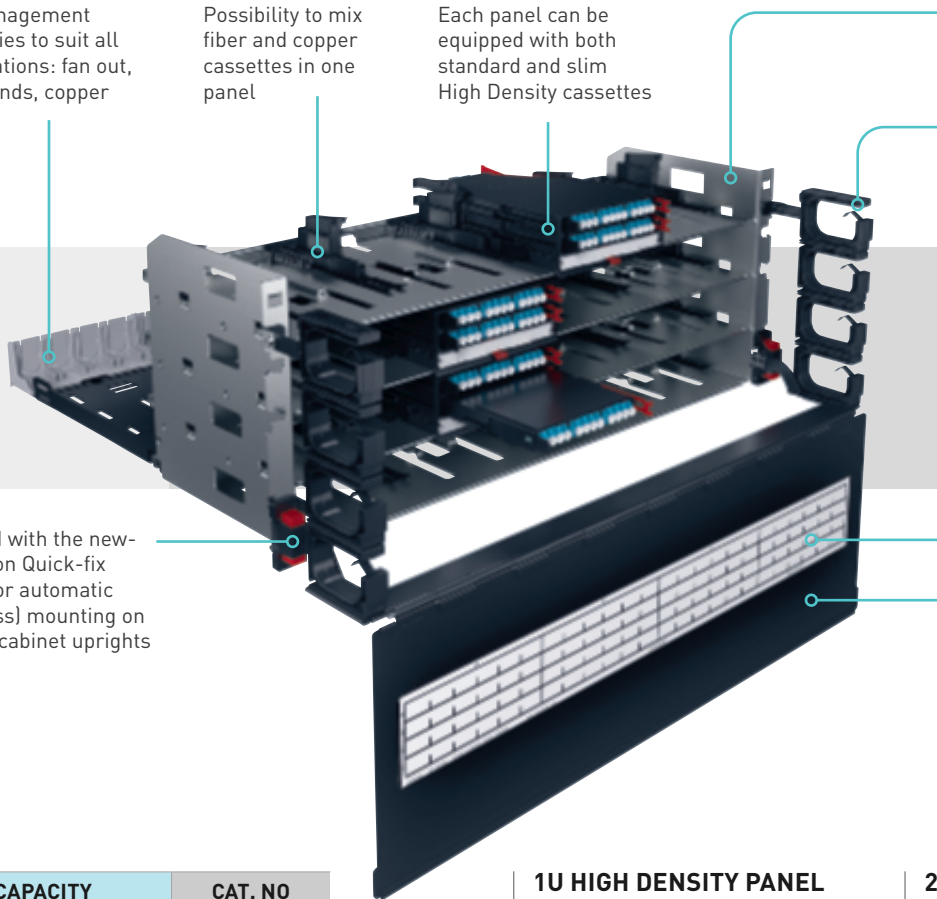

| CAPACITY              | CAT. NO  |
|-----------------------|----------|
| 1U High Density panel | 0 321 75 |
| 2U High Density panel | 0 321 76 |
| 4U High Density panel | 0 321 77 |

#### 1U HIGH DENSITY PANEL

Can hold up to 8 slim cassettes (into 4 supports)

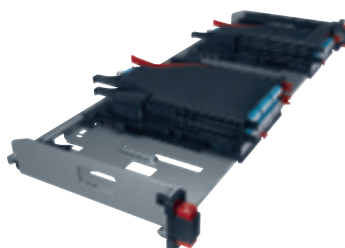

#### 2U HIGH DENSITY PANEL

Can hold up to 16 slim cassettes (into 8 supports)

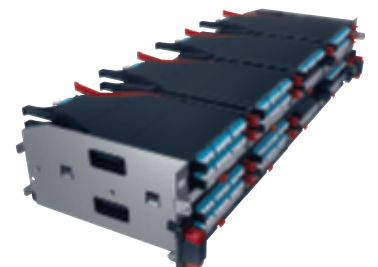



## FLEXIBILITY OF INSTALLATION

Our high density modular panels offer complete freedom of installation: opt for a top-of-rack or an in-rack installation depending on your site constraints and your infrastructure's configuration!

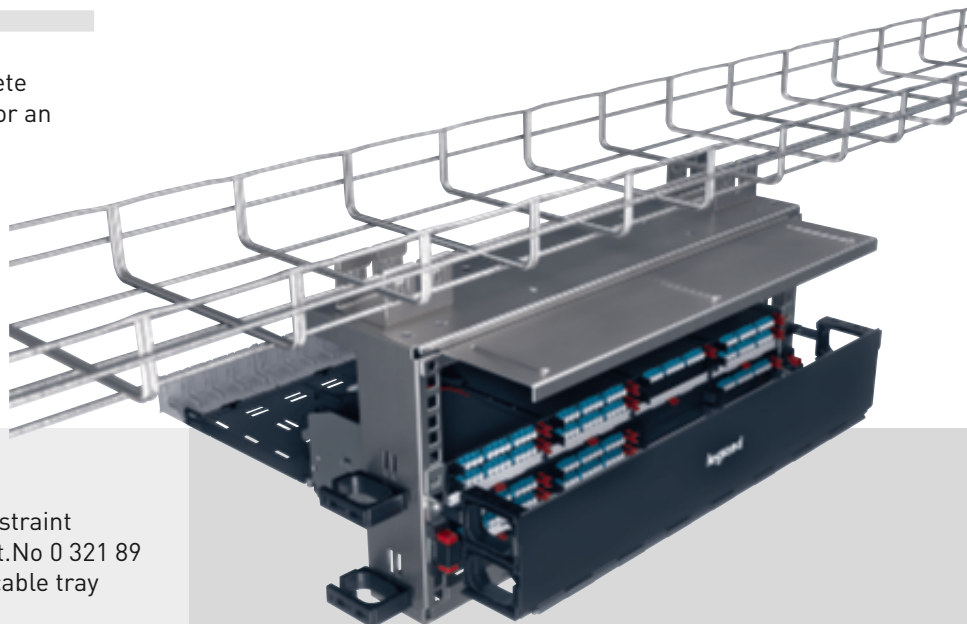

### TOP-OF-RACK INSTALLATION

Optimize space and meet any technical constraint thanks to the overhead solution! The kit Cat.No 0 321 89 enables you to fix the modular panels to a cable tray (Cablofil) above of the enclosure.

### IN-RACK INSTALLATION

Easily mount the modular panels directly into the LCS<sup>3</sup> enclosures and equip them with any type of cassettes in order to meet your specific needs!

- 1U, 2U and 4U panels equipped with:
- slim cassettes
  - splice cassettes with 8 MTP adaptors
  - copper cassettes
  - blanking cassettes



### UNIVERSAL FIXING

Thanks to the Zero-U kit, you can mount cassettes on 19" uprights, raised access floors, wire and sheet metal cable trays, structural uprights of the enclosure, etc.

## FIBER OPTIC SYSTEM CASSETTES

### SLIM SOLUTIONS FOR GREATER CONNECTIVITY

Optimize space and increase the connectivity capacity of your infrastructure with the slim cassettes! Easy to install and to maintain from rear and front, they prove to be agile and flexible under all circumstances.

- Mounting either on High Density modular panels or in Zero-U kit
- Single-mode and multimode MTP solutions that can be mixed on the same support
- Sliding cassettes individually removable from front and rear: accessible and easily manageable
- Equipped with extraction button for easy maintenance: reduced time, cost and risk of MAC
- High-performance with low insertion loss
- Universal polarity offering flexibility in case of changes

| TYPE                  | CAT. NO   |
|-----------------------|-----------|
| 12 LC OM5 multimode   | On demand |
| 12 LC OM4 multimode   | 0 321 69  |
| 12 LC OM3 multimode   | 0 321 68  |
| 12 LC OS2 single-mode | 0 321 70  |
| Blanking module       | 0 321 39  |



OM4 multimode slim cassette - Cat.No 0 321 69



OS2 single-mode slim cassette - Cat.No 0 321 70

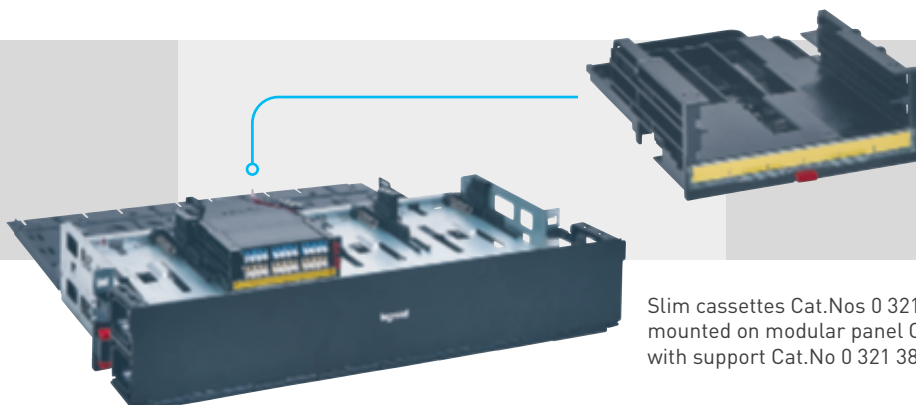

Slim cassettes are to be mounted on HD modular panels with support Cat.No 0 321 38. The support can take up to 2 slim cassettes.

Slim cassettes Cat.Nos 0 321 69/70 mounted on modular panel Cat.No 0 321 76 with support Cat.No 0 321 38

# FIBER OPTIC PATCHING KITS

## ZERO-U KIT FOR UNIVERSAL FIXING

The Zero-U kit Cat.No 0 321 03 enables you to mount cassettes on 19" uprights, raised access floors, wire and sheet metal cable trays, structural uprights of the enclosure, etc.

The kit can take up to 2 slim High Density cassettes Cat.Nos 0 321 68/69/70 or 1 universal High Density cassette Cat.No 0 321 59 or 0 321 60.

- Efficient solution to optimize space without the need to add an enclosure
- Compatible with 1U, 2U and 4U High Density modular panels
- Easy mounting on cable trays (such as Cablofil) thanks to quick-fixing solutions



## 1U TO 4U KIT FOR OVERHEAD FIXING

No space available in your LCS<sup>3</sup> enclosure? The innovative kit Cat.No 0 321 89 enables you to fix the High Density modular panels on wire cable trays, above the enclosure.

- Perfect toolless fitting on cable trays. Can also be installed on roofs of racks
- Maintains duplex multimode fiber architecture
- Scalable (move, add, change) and efficient (space optimization) system
- Easy installation and maintenance
- Can be equipped with fiber optic and copper solutions
- Compatible with automatically removable cassettes
- Accommodates the same solutions as 19" patch panels

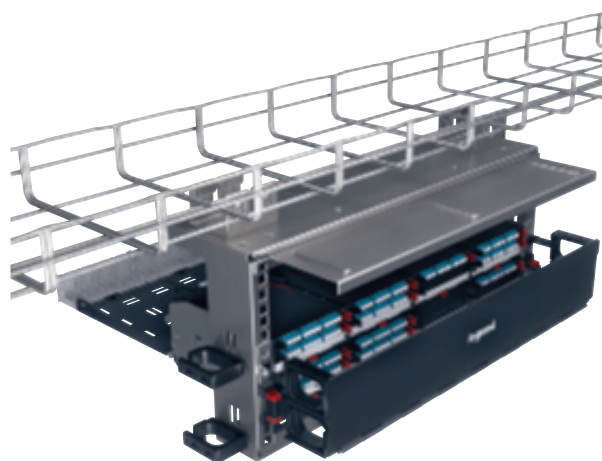

## FIBER OPTIC SYSTEM READY FOR FUTURE APPLICATIONS!

With our on-demand OM5 offer, we meet all your requirements in terms of connectivity! The infrastructure can easily evolve from 25 G or 50 G to 100 G and to 400 G thanks to parallel and multiplexing applications.

OM5 multimode MTP adaptor



OM5 12 LC multimode block

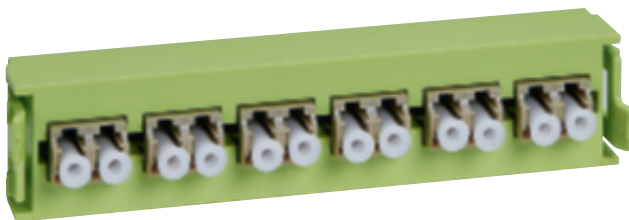

### PERFORMANCE AND WAVELENGTH

OM3 and OM4 fibers are optimized according to the wavelength traditionally used: 850nm. To accept the 4 signals used in multimode WDM, OM5 has been redesigned to accept wavelengths from 850nm to 950nm. The diagrams below provide a graphical representation.

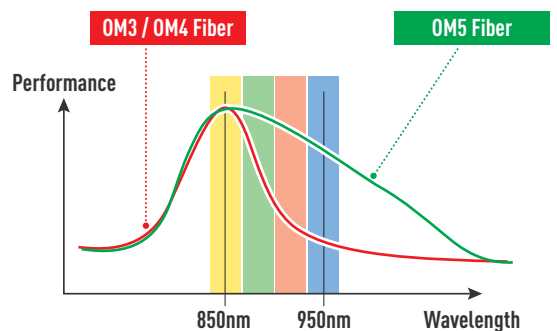
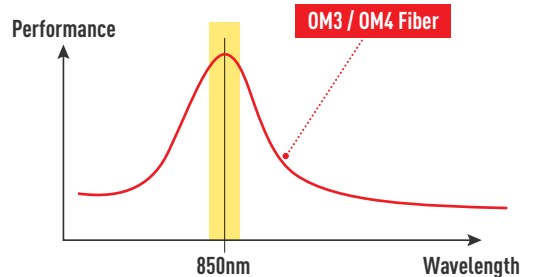

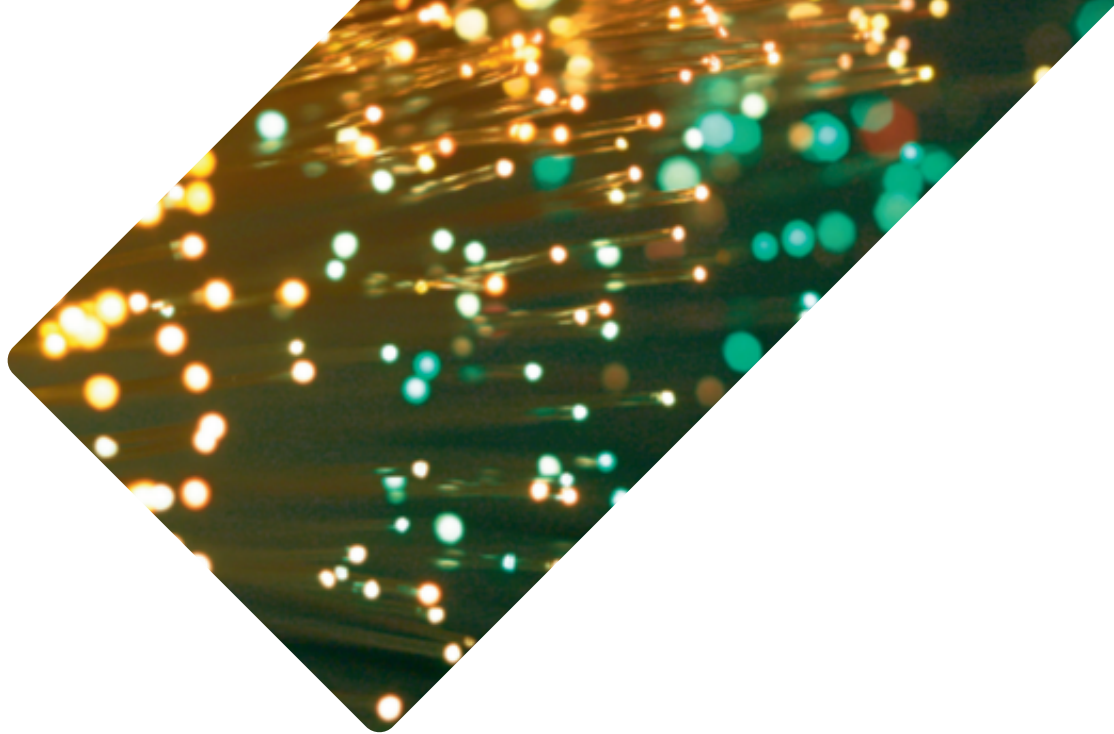

## APPLICATION UPGRADES

By considering all the current applications, either standardized or recognized through multi-source agreements, as well as draft applications to be standardized soon, we can establish the following evolutions of the applications optimized per type of multimode cabling:

- 1** Duplex channel for single wavelength (typically duplex LC connector with OM3 or OM4 fiber):  
10GBASE-SR → 25GBASE-SR → 50GBASE-SR\*
- 2** Duplex channel for multiple wavelength (typically duplex LC connector with OM5 fiber):  
10GBASE-SR → 25GBASE-SR → 40G-SWDM4 → 50GBASE-SR → 100G-BiDi or 100G-SWDM4\*
- 3** Multiple fiber solution for parallel optics (typically MPO connector with OM3 or OM4 fiber):  
40GBASE-SR4 → 100GBASE-SR4 → 200GBASE-SR4\*
- 4** Multiple fiber solution for parallel optics and multiple wavelengths (typically MPO connector with OM5 fiber):  
40GBASE-SR4 → 100GBASE-SR4 → 200GBASE-SR4 → 400GBASE-SR4.2 or 400G-BD4.2\*

## THE BEST OF BOTH WORLDS

To ensure the maximum lifespan of the fiber cabling, it is important to select the right fiber type and design. Today, a duplex OM4 channel can only expect to reach 50Gbps to the maximum distance. To reach 200Gbps, two options are available: duplex channel for multiple wavelength or multiple fiber solution for parallel optics.

But to reach 400Gbps, the best solution is the combination of all technologies together.

To allow the multimode fiber infrastructure to reach 400Gbps, the best option today is to provide for the full range of technologies. This currently means using OM5 cables with MPO connectors.

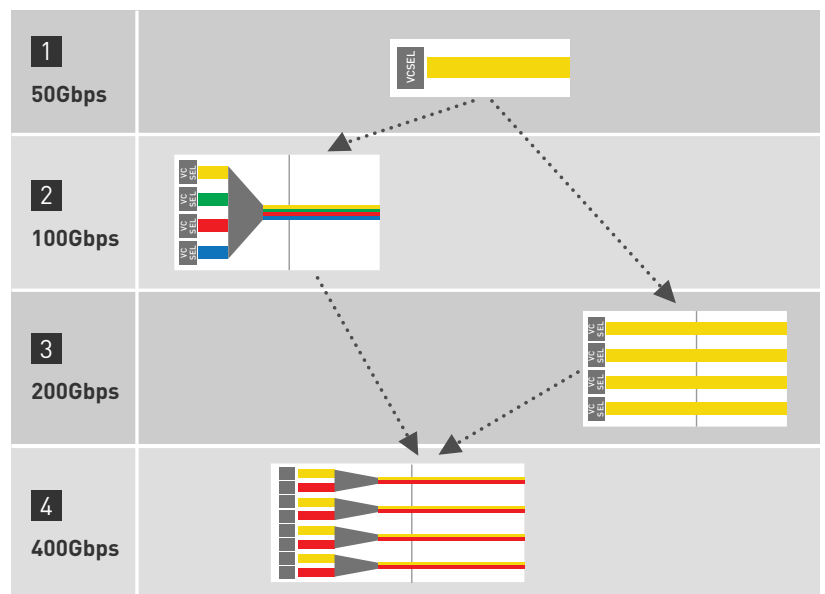

\*See TR ISO/IEC 11801-9908: "Guidance for the support of higher speed applications over optical fiber channels" for further information. Note that some multiple wavelength applications can function on OM3 and OM4, but to limited distance.

CONTACT US FOR MORE INFORMATION ABOUT THE CUSTOMIZED OFFER

# Efficiency

Legrand's LCS<sup>3</sup> system offers you copper and fiber optic solutions designed to enhance your infrastructure's efficiency:

- ▶ 48 ports per unit for high density (Copper system)
- ▶ 90 LC per unit for high density (Fiber optic system)
- ▶ 144 LC per Unit for ultra-high density (Copper and Fiber optic systems)

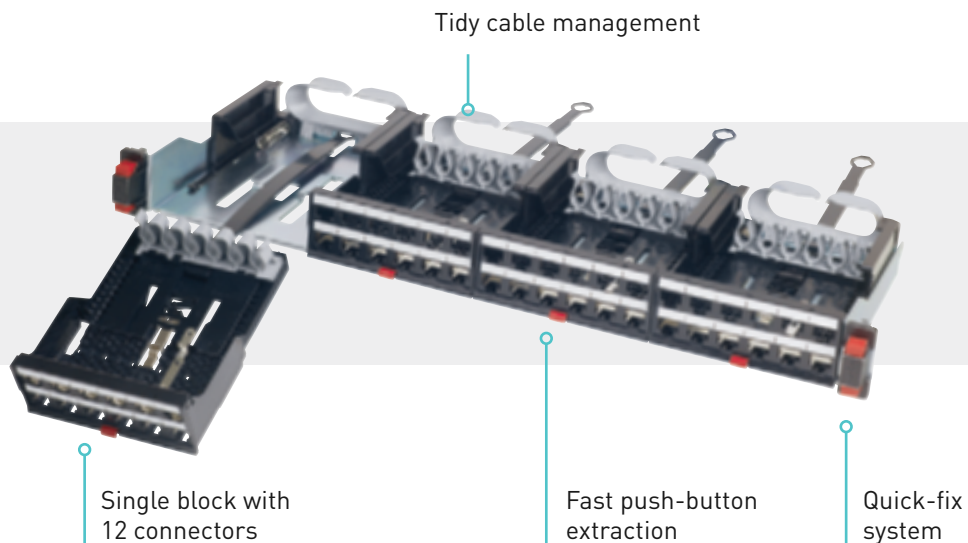

## COPPER SYSTEM PATCH PANEL HD SOLUTION UP TO 48 PORTS PER UNIT

High-density patch panel. It has changed from 24 to 48 ports, guaranteeing a reduction in space occupied and making future upgrades easier. Designed to house 4 blocks of 12 connectors each.

# FIBER OPTIC SYSTEM VERY HIGH DENSITY UP TO 144 LC/1U

Since different network architectures such as top-of-rack, end-of-row and middle-of-row require different cabling densities, passive equipment needs to adapt perfectly to the active network.

The LCS<sup>3</sup> HD cassette panel provides a mixed-media structured cabling system to support any configuration.

Legrand LCS<sup>3</sup> offers an innovative UHD patch panel designed to house up to 144 connections in 1U distributed between 6 individual modules of 24 fibers each.

Each module accepts incoming fibers both from MTP<sup>®</sup> trunk cables and via predetermined components. Predetermined cables are available both as breakout cables and as distribution cables.

## ULTRA HIGH DENSITY (UHD)

- Up to 144 LC/1U
- 1U, 2U, 4U
- Microcable preterms

Preterminated: the fiber optic cable termination is the addition of connectors to each optical fiber in a cable. The connectors are assembled in our factories

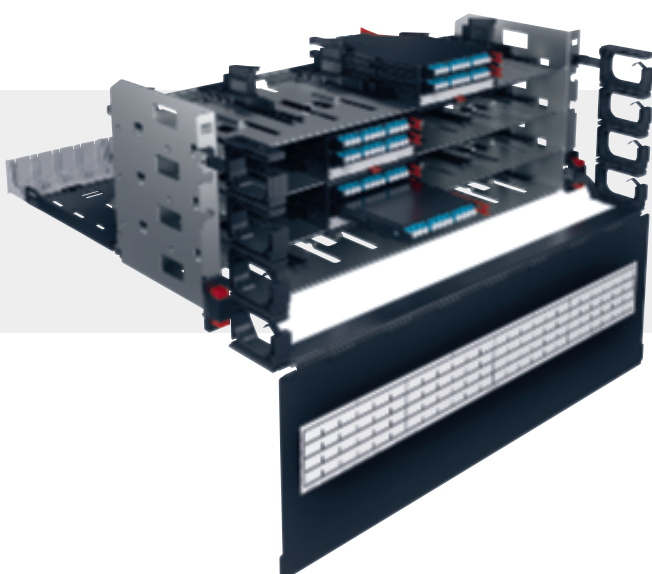

## HIGH DENSITY (HD)

- Up to 96 LC/1U
- Available in 1U, 2U and 4U

## COPPER SYSTEM EASY INSTALLATION WITH CAT. 5e/6/6A FIELD PLUGS

These accessories are ideal for a link terminated with a plug on active equipment side (CCTV camera, Wi-Fi access point...). It provides cost savings (faster installation) whilst ensuring an increased reliability.



Cat. 5e & Cat. 6 UTP  
RJ 45 field plugs



Cat. 5e & Cat. 6 FTP  
RJ 45 field plugs



Cat. 6A STP toolless  
RJ 45 field plug





# FIBER OPTIC SYSTEM INNOVATIVE CASSETTES FOR EASY INSTALLATION

Legrand has launched innovative splicing cassettes which can be removed automatically by simply pressing them, simplifying installation and maintenance.

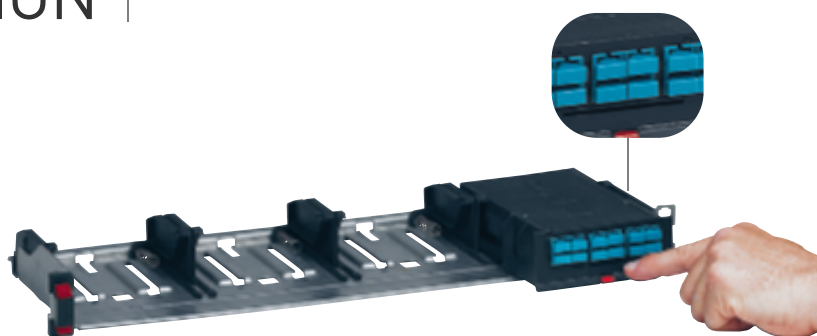

- For installation directly in modular panel Cat. No 0 321 40.
- The splicing cassettes are removable from the front.

## READY TO BE USED IN 1 CATALOGUE NUMBER!

- Pre-equipped cassettes with fitted fiber optic block (SC duplex or LC duplex, monomode or multimode)

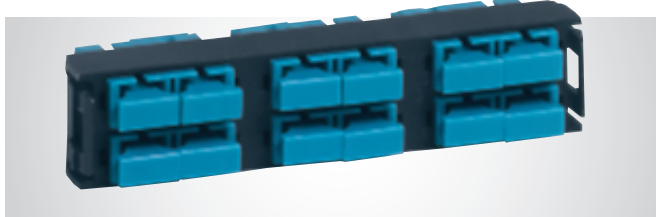

SC duplex high density fiber optic block for 12 multimode fiber optics

- Supplied with sets of 6 or 12 pigtailed



Set of 12 OM3 LC-PC pigtailed

- A very large offer of pigtailed in 1 or 2 meters ; in OM3, OM4, OM5 on-demand, OS2 (OS1a compatible). Sets of 12 LC pigtailed in OM3, OM4, OS2 (OS1a compatible)

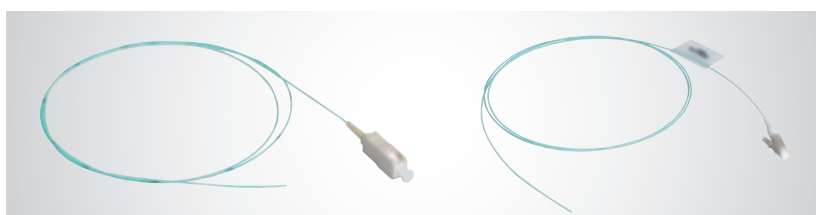

OM3 (PC) pigtailed, SC connectors

OM4 (PC) pigtailed, LC connectors

# LCS<sup>3</sup>

A GLOBAL  
OFFER

## 19" Enclosures

# Astuteness

The digital revolution is happening: it's taking place both in our personal and business lives. The way we do our work, listen to music, interact with people, research products and buy services has almost entirely changed. And so have IT infrastructures to make this change possible.

An ever-increasing amount of data, faster processing speeds, larger storage requirements, the exponential rise in IoT and artificial intelligence, and so forth have posed new challenges in technical rooms and data centers; hence the need for clever solutions to ensure ever more efficient infrastructures.



# 19" SERVER CABINETS

Carefully thought out, for a reliable and efficient design, Legrand's range of server cabinets stands out for its inventiveness.

## NEXT LEVEL SOLUTIONS

We've researched, analyzed, discussed, checked and rechecked ways we could optimize the technical room and data center infrastructures. Can they work smarter, better and more sustainably? How can we provide smart solutions to cope with the challenges in these markets? Can we develop systems to help companies comply with various environmental requirements and compliancy laws? Can we act with greater corporate social responsibility across every aspect of our business?

**Our mission with the development of our new platform was to create something that's smart, solid, secure & sustainable.**



### WHAT WE PROMISE

A technical room or data center must accommodate IT infrastructure in the most efficient way possible. Infrastructure needs the space to grow and evolve with new circumstances, technology, and user requirements. Therefore, modifications and innovations are also necessary for next level cabinets to help ensure improved uptime, efficiency, security, and sustainability.

**The LCS<sup>3</sup> cabinet platform offers you the space to accommodate whatever comes next!**



## SMART: UNLIMITED POSSIBILITIES

A smart design was one of the main requirements by developing the LCS<sup>3</sup> platform. With LCS<sup>3</sup> we went the extra mile with the flexibility and modularity of the installation and infinite adjustment of accessories and components. It's truly the next level in technical room and data center infrastructures.

This is a huge leap forward for our customers. The design has been achieved by working closely with our customers for many years. During the design we constantly looked to expand possibilities and provide high levels of scalability. The functionality has been seamlessly integrated into the aluminium frame providing a fully integrated platform and the opportunity to be combined with systems and products from the Legrand portfolio.

Stepless adjustability



**EFFICIENT, MODULAR EXTENSION**

For the interior of the server cabinet, aluminium extrusions are used, in which mounting rails are installed that are adjustable in the full width and depth. All the accessories can be mounted flexibly across all three dimensions and infinitely adjusted. In that way, the interior of the server cabinet can be custom designed without being dependent on specific holes or modular dimensions of holes. These holes would also negatively impact air tightness.

**INTEGRATION**

Within the new cabinet it is easy to add power distribution units and sensors which make it possible to remotely monitor your data center and cabinets. This enables users to stay in control (remotely) of the condition of the IT equipment and the environmental factors in the cabinet that relate to air humidity, temperature and air circulation.

Smart products from the Legrand portfolio can perfectly be integrated into our server and network cabinet platform. In this way, we deliver a total solution with which we can meet your every need.

**EASY MAINTENANCE**

Another unique property is the option to mount and remove all the accessories and components located in the cabinet from the inside. That means that – even if a cabinet is bayed or is closed – it is easy to change, remove or add practically everything from inside. System administrators or data center managers in particular can benefit tremendously from the flexibility that the interior offers. The interior makes cable management, adding components and making changes much easier.

**SMART TOP-OF-CABINET DESIGN**

The amount of cabling in cabinets has increased considerably. To be able to continue to meet the changing needs, we have developed a cabinet with a smart, optimized design. For example, the top-of-cabinet section contains more space to guide the cables through and the positioning of the entries is improved.

Modular roof

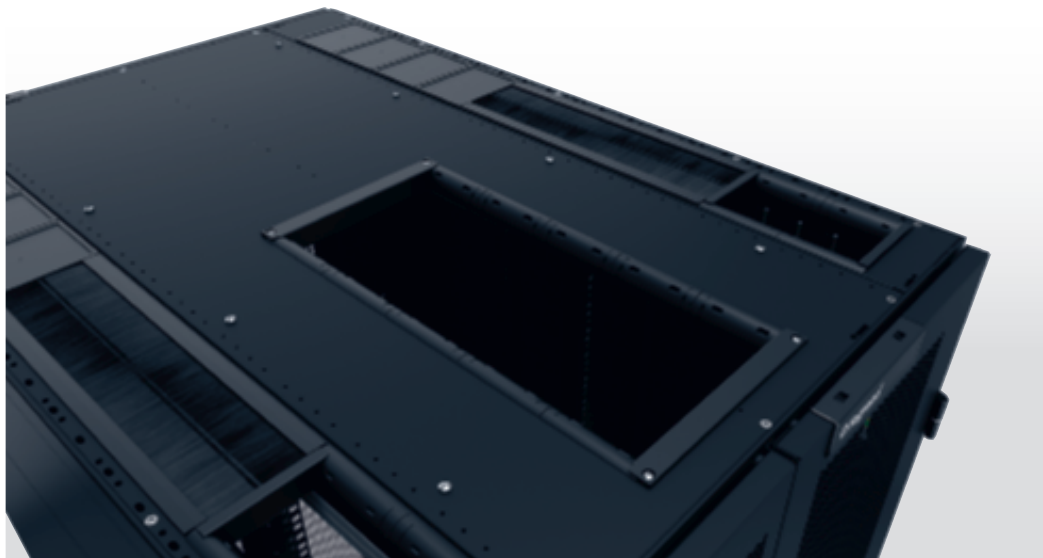

### SOLID: NEXT LEVEL RELIABILITY

The LCS<sup>3</sup> platform enables a solid structure to perfectly house your IT-equipment. The interior of our server and network cabinets has a light and solid aluminium frame to bear the weight of IT equipment and to deal effectively with airflow management. The sturdiness of the frame and door, the full integration of the locking system and the cabling are unique on the market.

### UNIQUE DOOR DESIGN

The full integration of the locking mechanism is unique. It is also easier to mount and remove the door, which can be useful during work in the cabinet. The door can also be easily reversed to make the door right-opening rather than left-opening.



A solid double door is also part of the LCS<sup>3</sup> platform, which can be very practical in case of limited space

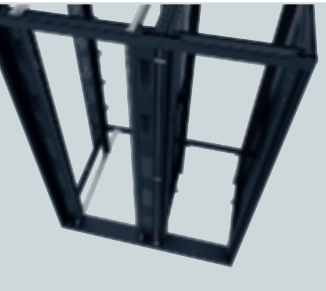

### LIGHT AND SOLID FRAME

The light and solid aluminium frame offers ultimate flexibility because mounting and T-slot rails are placed in aluminium extrusions. In that way, the interior of the cabinet can be perfectly adjusted to the user's requirements without being dependent on certain holes or modular dimensions of holes. It is therefore possible to install all the accessories that are intended for cabling or for holding IT equipment in exactly the spot where it can be used most effectively. It is important that the interior is easily adjustable – because not all the IT equipment that is placed in a cabinet is always delivered with the same standard dimensions.

Another unique property of the interior is the option to mount and remove all the accessories and components located in the cabinet from the inside. That means that – even if a cabinet is bayed or is closed – it is easy to change, remove or add practically everything from inside.

## SECURE: KEEP YOUR DATA SAFE

The greatest risk of any technical room or data center is downtime. The new platform enables the highest levels of access security and reliable intelligent power distribution. Innovative monitoring tools and sensors reliably work around the clock to detect and alert technical room or data center operators in case of sudden changes in and around the rack to prevent outages.

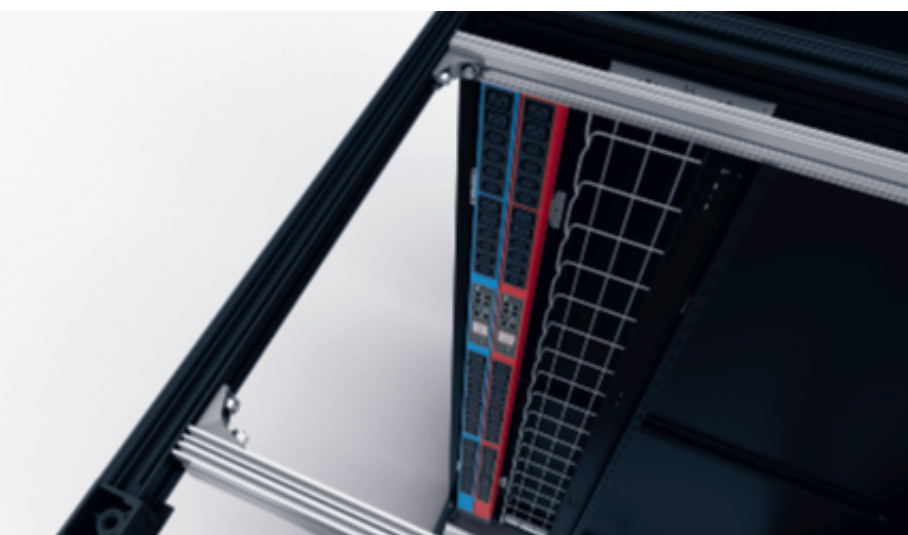

## RELIABLE POWER DISTRIBUTION

Power is an operationally critical component of any technical room or data center. Even the slightest interruption of the power supply can have a huge impact. The new cabinet platform makes it possible to manage the risks of power outages by using PDUs from the Legrand portfolio.

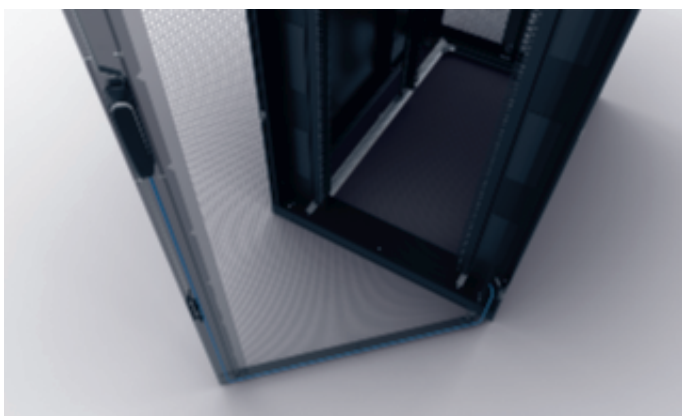

Full integration of the locking mechanism

### SUSTAINABLE: NEXT LEVEL ENERGY EFFICIENCY

With server cabinets in particular, the requirements in the area of energy efficiency are high. After all, the IT equipment in server cabinets produces a great deal of heat that must be removed efficiently. Indeed, in order to function as effectively as possible, the IT equipment must be adequately cooled, because the more efficient the cooling process is, the more reliably the IT equipment works, and the less energy is required to enable the data center to run.

The design of our server and network cabinets is specifically geared towards optimizing the energy efficiency of technical rooms and data centers. Increasing the energy efficiency was one of the most important reasons for developing this cabinet platform. By reducing energy consumption, technical rooms and data centers can not only save on costs, but can also reduce the impact on the environment.

#### Efficiency comparison between a standard and an airflow optimized cabinet

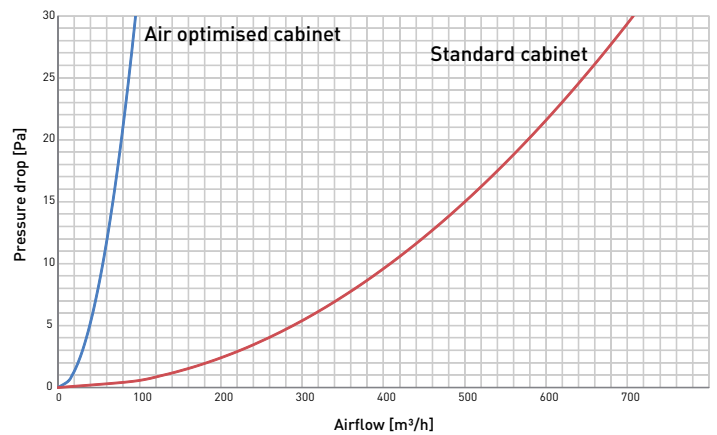

#### PREVENTING COOL AIR LEAKAGE

- **Airtightness at vertical mounting rail perimeter**

It is extremely important that air leakage and recirculation is minimized so that the cool air is guided exclusively through the IT equipment. To do this, the space between the frame of the cabinet and the steel profiles (in which the IT equipment is installed) must be perfectly sealed. In that way, the separation between the hot and cold airflows can be optimized.

To do this, airflow management packages can be used that consist of a bottom, top, left and right plate. These plates connect the cabinet with the profiles in which the IT equipment is installed.

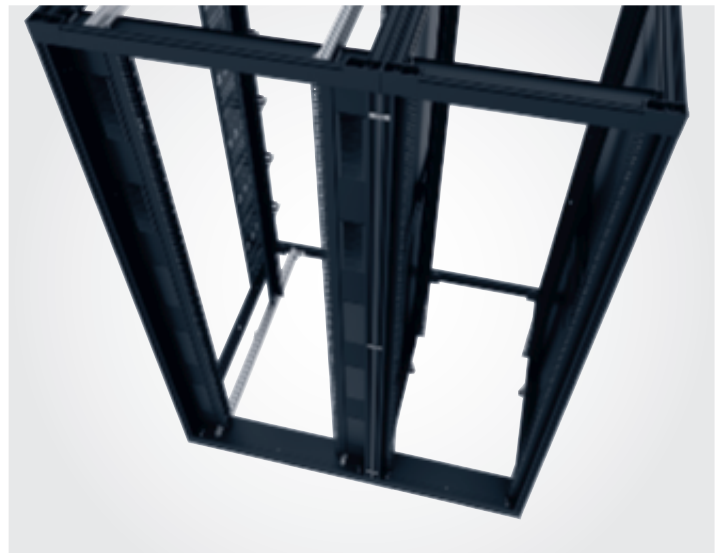

Airflow management for 600 mm and 800 mm wide cabinets

- **Airtightness at cabinet perimeter**

Special accessories have also been developed such as sealing strips. These strips are used to perfectly seal the spaces between the cabinets. If a cabinet is leveled or placed on castors the gap can be sealed with an airtight plinth.



Once we had established the platform’s functionality, we needed to establish the function of every component. We had a simple philosophy: if there is no clear added customer value, it isn’t part of LCS<sup>3</sup>! Every element plays a key role in the system’s functionality and performance.

The server and network cabinets have been designed based on the following principles:  
Design for Manufacturability, Design for Assembly and Environmentally Oriented Development.



**Design for Manufacturability** is a methodology in which the emphasis is on the producibility of the design.



**Design for Assembly** is a methodology for improving the ‘producibility’ of a product design.



**Environmentally Oriented Development** is about being mindful of the impact that the development of a product has on the environment. We can demonstrate this with a Product Environmental Profile.

### MANUFACTURING PROCESS

Our server and network cabinets have been specifically designed to help create technical rooms and data centers that are more environmentally friendly. The impact on the environment was also considered by using the most environmentally friendly materials possible in the manufacturing process of the cabinets and by avoiding the use of materials that are harmful to the environment. Additionally, several process steps are carried out internally rather than being outsourced, which contributes to a more environmentally friendly manufacturing process for the cabinets.

### DESIGN

The design is geared towards a more efficient use of energy in technical rooms and data centers by ensuring that the heat-generating IT equipment can be cooled as efficiently as possible. The cabinets have been designed in such a way that they enable optimal airflow management. This is because, by using airflow management packages and a wide range of accessories, air leakage and recirculation, and in turn excessive changes in temperature, can be avoided. This optimizes the reliability of the IT equipment, and ensures that less energy is required to enable the technical room or data center to operate. This can lead to cost savings.

## 19" CABLING RACKS AND CABINETS

With the development of connected solutions comes an ever-growing need for secure data and secure access, as well as reliability of the infrastructure. Legrand's VDI enclosures for LANs have been designed to adapt to these developments and accommodate increasingly high-performance solutions, both for your small installations and highly critical structures.

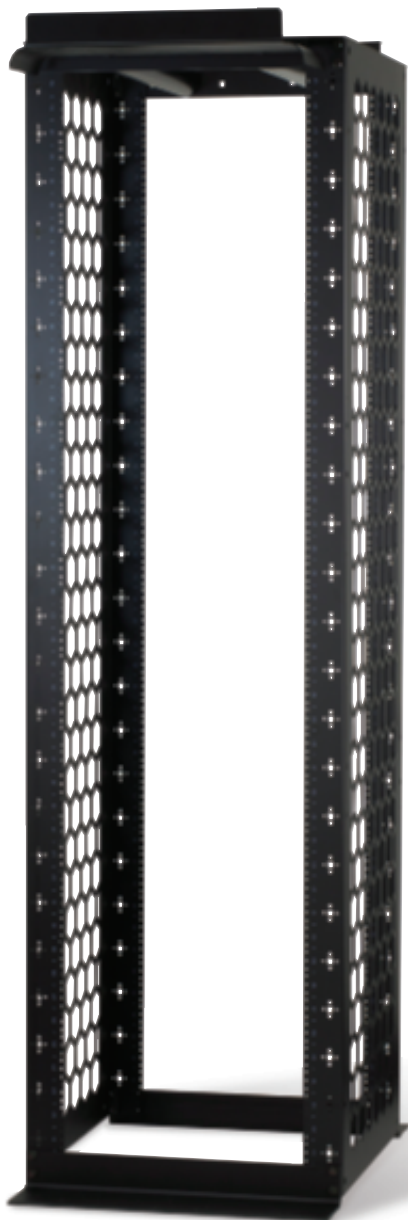

### LCS<sup>3</sup> CABLING OPENRACK

Open racks provide greater flexibility and optimum efficiency in any data center. The fixed racks provide an economical mounting platform for switches and servers while the adjustable rack allows all 4 mounting rails to be adjusted even after the rack has been fastened to the floor. Front waterfalls allow for equipment patching and server patching. Vertical managers can be mounted front and rear for a perfect management of patch cords.





### LCS<sup>3</sup> CABLING CABINET

Given how quickly IT technology evolves, a flexible, future-proof concept is essential. The LCS<sup>3</sup> cabling cabinet is specifically designed to meet these needs and stands out due to its versatility, ease of installation and ease of use.

The LCS<sup>3</sup> cabling cabinet is a multifunctional system, specifically designed for ease of installation.

The system is ultimately suitable for housing copper patch panels, fiber optic drawers, telephone panels, switches, routers and other IT equipment. Of course it is also possible to include a small number of servers.

### LCS<sup>3</sup> WALL-MOUNTING CABINETS

The basic frame is made up of a wall-mounting plate with integrated strain relief bar, four depth rails, two cable-entry plates (base and top) and a set of 19-inch rails. The assembly consists of two equal top and base panels with ventilation slots to the rear, two equal side panels and a safety glass door with an EK-333 cylinder lock with grip.



## Flexibility

The PDU offer combines Legrand's quality and innovation with a wide range of applications. A standalone solution, this range integrates seamlessly into any installation, ensuring compliance with applicable standards.

### SOLUTIONS FOR ANY CONFIGURATION



#### ZERO-U PDU

##### For data centers/server rooms

These are used in server cabinets where:

- there is a high density of active equipment
- electrical distribution quality is crucial

*For vertical installation*



#### 1-U PDU 19"

##### For data centers, edge server rooms and computer rooms

These are used in patching and server enclosures where:

- there is a low density of active equipment to be powered
- ease of installation is an advantage

*For vertical or horizontal installation*

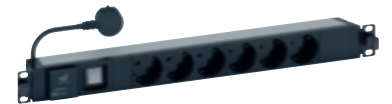

#### 1-U PDU 10"

##### For small IT environments

These are mainly used in small-scale commercial applications where there are a limited number of computer workstations and a 10" cabinet is sufficient: small businesses, freelance professions, administrative services, etc.

*For horizontal installation*



## ABOUT LEGRAND'S PDUS

### GENERAL CHARACTERISTICS

- Anodized aluminium chassis: high-quality material, lightweight and rigid
- Modular design: expandable socket and function modules

### SAFETY

- High-quality electrics
- High-quality connection
- Sockets equipped with safety shutter
- Cord Locking system

### POWER SUPPLY

- 16 A to 32 A, single - or three - phase
- PDUs incorporating both international and local type sockets

### SOCKET STANDARDS



C13



C19



German



French-Belgian



British



Nema S20



Swiss T13



Swiss T23



Italian



Chinese SP

### STANDARDS

**IEC 60950** - Information technology equipment - Safety

**IEC 60297-3** - Dimensions of mechanical structures of the 482.6 mm series (19 in)

**IEC 60320-2-2** - Appliance couplers for C13 and C19 electrical equipment

**IEC 60884-1** - French/Belgian and German standard plugs/sockets

**BS 1363-2** - British standard plugs/sockets

**IEC 60309** - Industrial plugs

**Certification: CE, TSE, CCC**

**Environmentally-friendly products**  
Eco-design



# LCS<sup>3</sup>

A GLOBAL  
OFFER

## Power Distribution Units

# Reliability & Safety

By bringing intelligence and innovation to the heart of networks, Legrand's PDU range ensures both reliability and safety in all types of infrastructure, from complete data centers to small-scale deployments.

### CORD LOCKING SYSTEM INNOVATION AT THE HEART OF PDUS FOR C13 & C19 SOCKET OUTLETS

Security of cable connection at rack level is a critical element which must be considered to ensure longevity of the installation. All Legrand PDUs have a power supply cord locking system which prevents accidental disconnection due to human error or vibration and guarantees absolute safety.



### EASY IDENTIFICATION

Very easy to identify thanks to the orange buttons next to each socket outlet

AN INNOVATIVE TECHNICAL SOLUTION

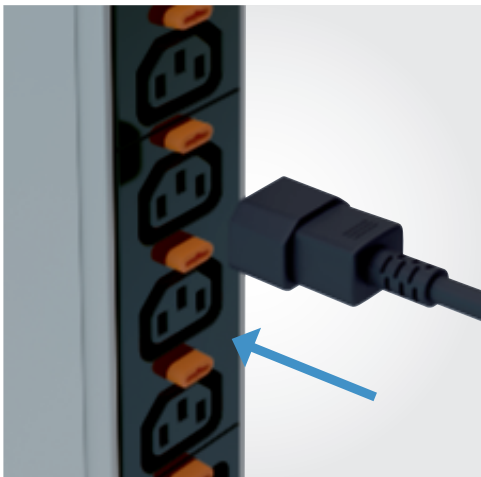

**CORD CONNECTION**

The cord is connected to the socket naturally in one smooth action

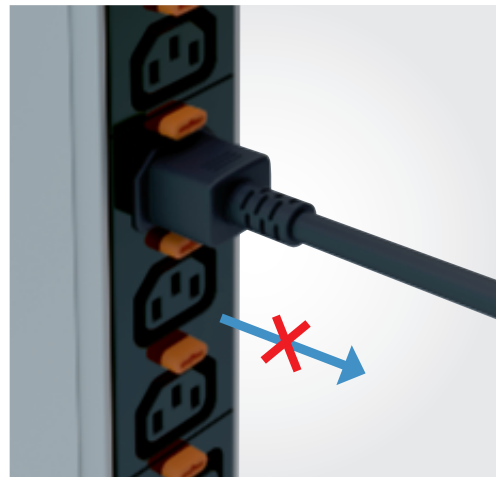

**AUTO LOCKING**

Cord held in place: once the power supply cord is connected, it locks automatically and cannot be removed

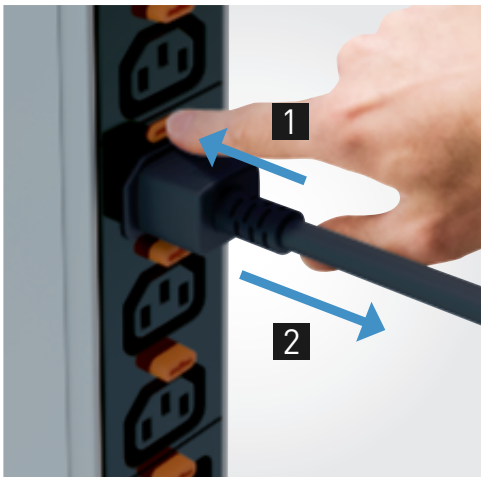

**UNLOCKING**

Easy removal: simply pressing the unlock button releases the cord from the socket

UNIVERSAL SYSTEM

Takes all cords for standard C13 and C19 sockets

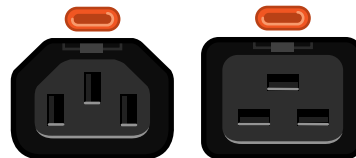

✓ EXCLUSIVE TO LEGRAND

## ZERO-U PDUS INNOVATION & PERFORMANCE: EXCLUSIVE INNOVATIONS

Every detail matters! Legrand's unique and original innovations help ensure optimum performance for the ZERO-U range of PDUs, in terms of safety, simplified setup and integration, consumption indicators, etc.

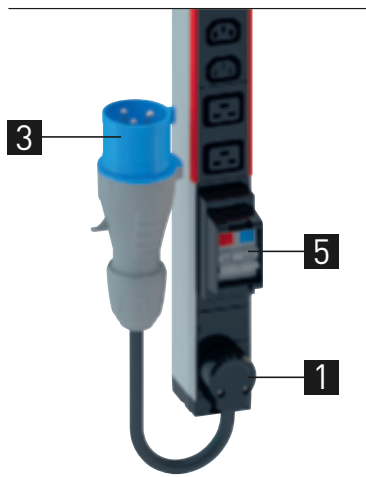
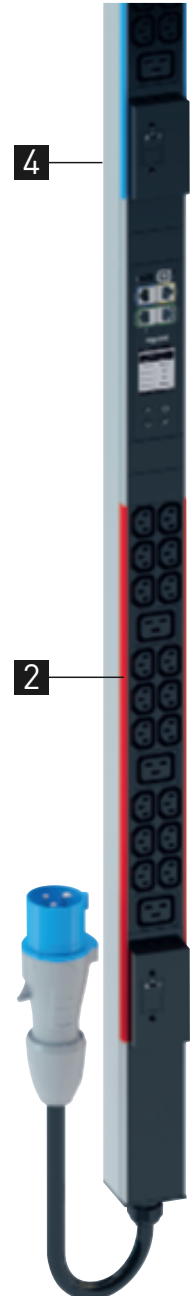



## STANDARD STRUCTURE FOR BASIC PDUS

### ROTATIVE CABLE ENTRY

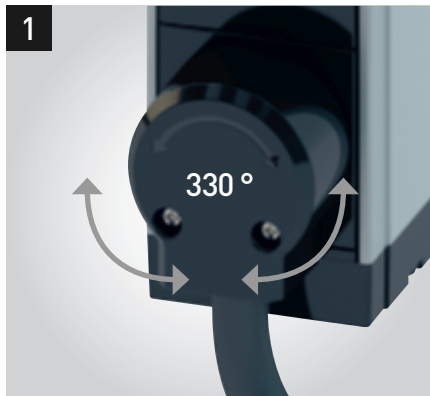

#### Cable orientation

330° rotatable cable entry for perfect cable orientation and no interference in the cabinet

### CIRCUIT MARKING

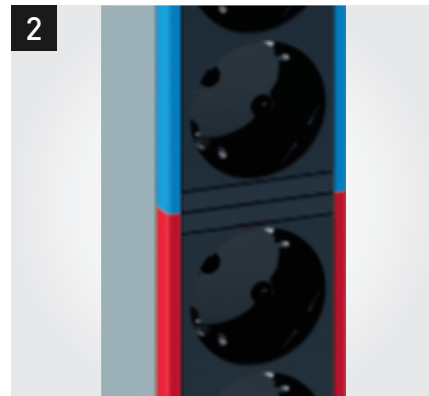

#### Circuit identification

Each circuit is colour-coded, with the colour visible on the front panel and along the edges of a module. The colour corresponds to the specific MCB protecting the circuit.

### ROTATIVE CABLE ENTRY

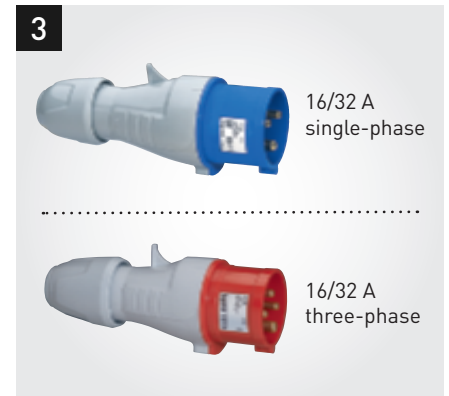

#### Enhanced protection

There are multiple solutions depending on power supply requirements

### SCREWLESS MOUNTING

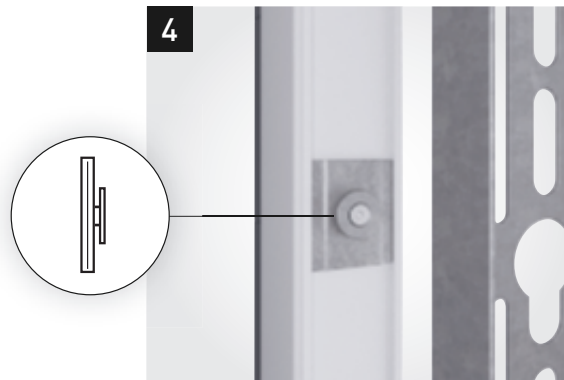

#### Fixed in buttonhole slots

ZERO-U PDUs simply clip vertically into buttonhole slots on the mounting bracket without the need for any screws.

### CIRCUIT BREAKER HOLDER



#### Enhanced protection

Circuits protected by a circuit breaker. Holder with overhanging edges to prevent accidental breakages. (Cover available on request)

## 1-U PDUS INNOVATION & CONVENIENCE: SIMPLE SETUP & INTEGRATION

The 19" PDUs designed for installation in server cabinets and patch panels also incorporate the latest innovations for facilitating integration and maintenance, with clever mounting and operating features.

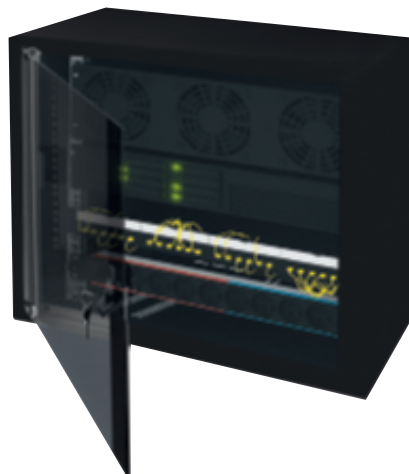
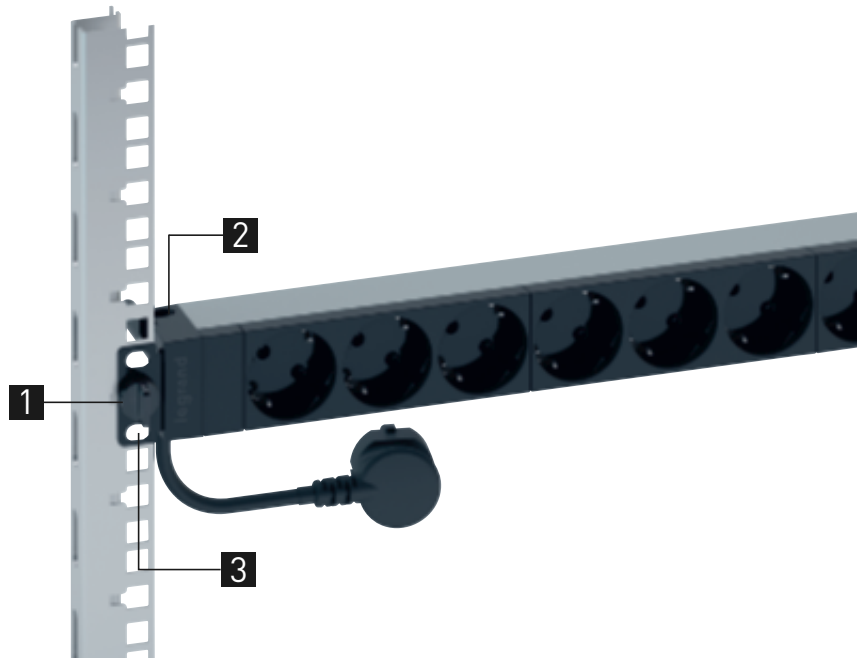

### PDU 1 U 10"

Specially designed for local area networks, these PDUs feature the same innovations as the 19" range.

**HORIZONTAL  
INSTALLATION**



HORIZONTAL  
OR VERTICAL  
INSTALLATION

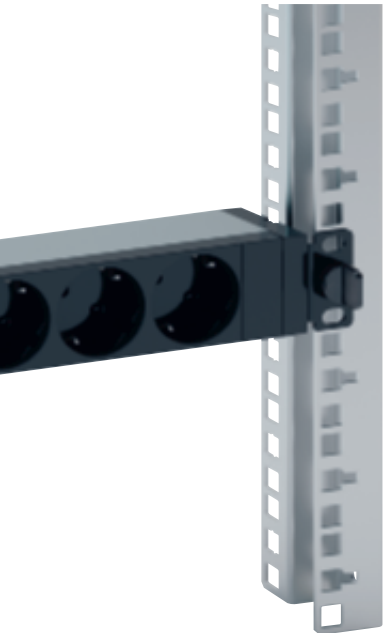

### SNAP-ON FIXING

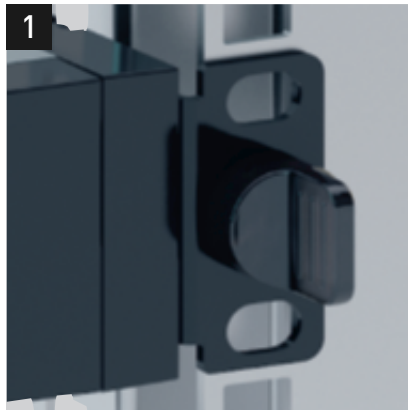

**Toolless installation**  
Snap-on fixing on 19" uprights  
No need for screws or nuts.  
Toolless installation.

### CABLE GUIDE



**Optimising space**  
Cables are held firmly in place by a cable guide.

### MOUNTING BRACKETS

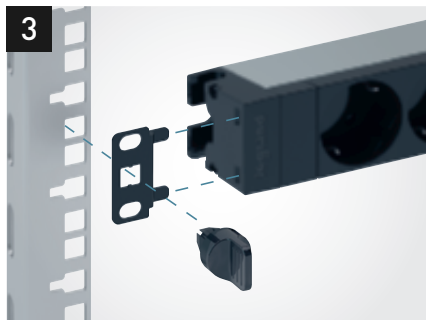

**Horizontal or vertical**  
Designed for horizontal toolless mounting, 1-U PDUs can also be mounted vertically simply by rotating the mounting lugs.

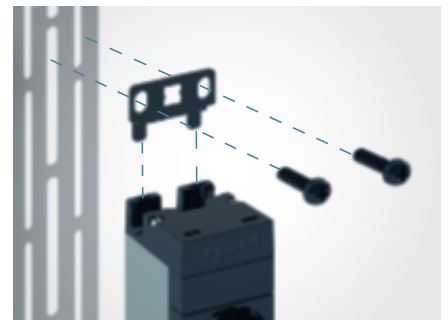

Vertical mounting requires a bolt and nut to fix the PDU securely to the bracket.

 EXCLUSIVE TO LEGRAND

## ACCESSORIES FOR PROTECTION: ENHANCED SAFETY CONTROL

Compatible with all the PDUs in the Legrand range, the complementary accessories allow you to control the socket power supply and protect against overvoltages.

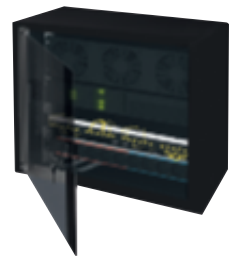

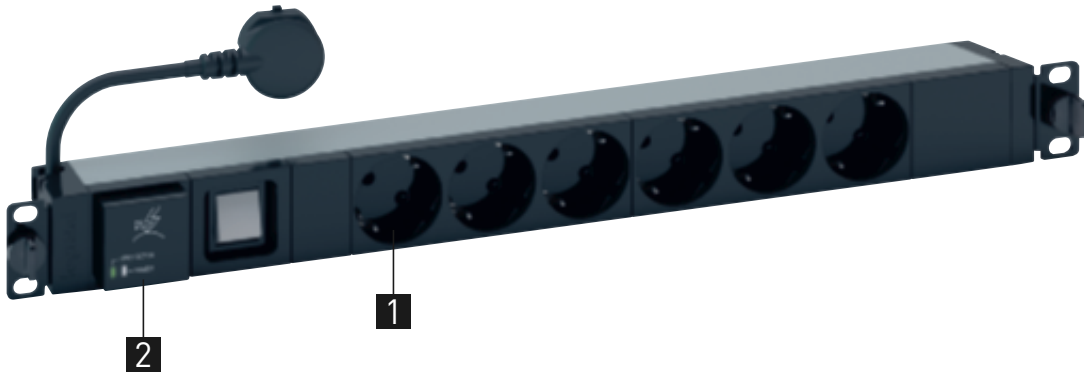

## SOCKET LOCKING CAP



### Controlling access to the power supply

The locking cap can be used to lock access to a socket. A special key is required to unlock it. Locking caps are available for the following socket standards: C13, C19, German, French-Belgian, British.



## SURGE PROTECTIVE DEVICE



### Modular Surge Protection

The surge protection module protects equipment against overvoltages and incorporates hot swap technology. It can be used to replace a used module without interrupting the power supply to the other equipment connected to the PDU.

This is an essential accessory for business servers which need continuous protection. The module is equipped with a warning LED which indicates when it needs replacing.

EXCLUSIVE TO LEGRAND

## Support you can rely on

It takes more than just sophisticated technological solutions to manage international projects successfully. What is really needed is the comprehensive and expert support of an experienced partner: from project design and choice of the right solution through to on-site logistics, installation and configuration, including any subsequent troubleshooting and maintenance.

### YOUR PARTNER EVERY STEP OF THE WAY!

Legrand is ideally placed to offer this type of support, as all its products and solutions are developed and produced in close proximity to its customers.

Legrand also offers a wide range of special services and support tools which create genuine added value by making customers' day-to-day business significantly easier. This support is available at every stage of the project, whatever the customer touchpoint.

**A diverse range of digital tools** including websites, social media and news feeds so you can contact Legrand at any time and stay up to date with all essential news that is relevant to your projects.





**Personal advice, technical support and documents**, white papers, catalogues and e-catalogues, and BIM objects to help with product choice or drawing up bills of materials.



**Training courses** covering actual product expertise as well as the latest developments in technology, standards and regulations. Customized training courses available on request, either face to face or in virtual online classes.



**Confident in the quality of its solutions, Legrand offers to warranty continuity of performance of its cabling system for copper and/or fiber optic over 25 years.**



—  
**Technical  
appendices**  
—





# Standards

## Introduction to standards

Standards, by definition, are voluntary. Projects must always be compliant to:

- Laws
- Regulations
- Codes

Then standards are used as methods to ensure inter-operability of the systems used. These are chosen according to the needs of the project.

The international standard for telecommunications cabling infrastructure is the ISO/IEC 11801 series.

This standard is adopted by many countries after eventual translation.

The EN 50173 series is the equivalent European standard. It is adopted by all European countries.

While there are multiple national standards, the most significant is the ANSI/TIA, from North America (for both USA and Canada), and is voluntarily used in many other countries. These 3 series are described below.

In general, a project should be compliant to the national standard, if existing, and it may also be chosen to be compliant to the international standard to ensure full compatibility. But it would be unusual for a project in a country with a national standard to require only compliance to a national standard for another country. This would increase risks of noncompliance

to national regulations and could add difficulty to source the products.

For example, some of the installation standards are adapted to specific construction methods or fire codes.

Below is a table of recommended and not recommended compliance options, for a project in country "A":

| Condition  | Recommended   | Not recommended   |
|--|---|---|
| <b>Country "A" has a national standard</b>           | Compliance to country "A" standard only*                      | Compliance to country "B" standard only                     |
|  | Compliance to country "A" standard and international standard | Compliance to country "A" standard and country "B" standard |
| <b>Country "A" does not have a national standard</b> | Compliance to international standard only                     | Compliance to country "B" standard only                     |

\* This is assuming that country "A" has absolutely all requirements in the standards. This is extremely rare and very often the national standards will cite international standard for information not available in national documents.

For performance measurements, compliance to multiple standards can be required for specific customer needs, provided that they can be done with a harmonized test method and compared to various test limits in the software after testing.

Because PoE compliance is linked not only to the performance standards, but also to electrical standards, codes and regulations, it is critical to always choose the correct framework to avoid safety risk.

This document does not state all standards but only the primary ones needed for a compliant installation.

**In the process of a Legrand 25-year warranty outside of North America, compliance to ISO/IEC or CENELEC is required.**

This warranty is not applicable in North America. Contact Legrand local support to obtain the correct documents if needed for this region.

## ISO/IEC 11801 series

### GENERAL INFORMATION

ISO/IEC 11801 series is the international standard for generic cabling for customer premises. It is the most extensive series and is directly linked to IEC documents.

### GENERAL REQUIREMENTS

The general architectures and the performance are in the **ISO/IEC 11801-1**: General requirements. It covers:

- Balanced cabling channels and links performance
- Coaxial cabling channels and links performance
- Fiber cabling channels and links performance
- Component requirements to meet those needs, citing the IEC documents for details

### DEFINITION OF THE PROJECT

First the project type must be selected:

- **ISO/IEC 11801-2**: Office premises
- **ISO/IEC 11801-3**: Industrial premises
- **ISO/IEC 11801-4**: Single tenant homes
- **ISO/IEC 11801-5**: Data centers

The **ISO/IEC 11801-6**: Distributed building services, may also be added as part of the project requirements if the cabling infrastructure covers not only cabling for information technology but also building services.

### DESIGN AND INSTALLATION

These following 3 standards are required for compliance:

- **ISO/IEC 14763-2**: Planning and installation implementation.
- **ISO/IEC 14763-2-1**: Identifiers within administration systems
- **ISO/IEC 30129**: Telecommunications bonding networks for buildings and other structures

The ISO/IEC 11801-6: Distributed building services, may also be added as part of the project requirements if the cabling infrastructure covers not only cabling for information technology but also building services.

### TESTING

The copper testing is found in an IEC document: **IEC 61935-1**: Installed balanced cabling as specified in ISO/IEC 11801-1 and related standards.

**ISO/IEC 14763-4** is a new addition covering limits for MPTL (Modular Plug Terminated Links).

The fiber testing is found in **ISO/IEC 14763-3**: Testing of optical fiber cabling.

## DIAGRAM

The diagram of compliance is the following:

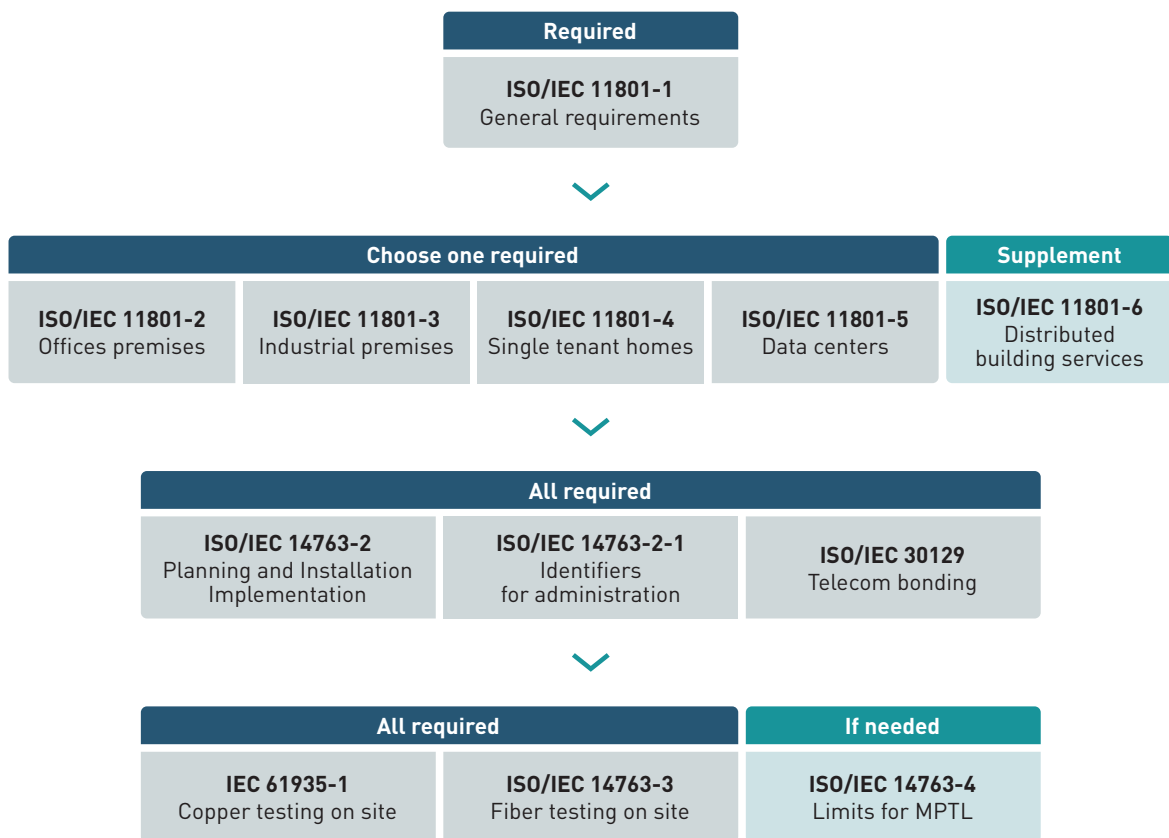

## CENELEC EN 50173 series

### GENERAL INFORMATION

The CENELEC EN 50173 series is the European standard for generic cabling for customer premises. It is extremely similar to ISO/IEC 11801 series with some adaptation for the European market. It is also linked to the IEC standards.

### GENERAL REQUIREMENTS

The general architectures and the performance are in the EN 50173-1: General requirements. It covers:

- Balanced cabling channels and links performance
- Coaxial cabling channels and links performance
- Fiber cabling channels and links performance
- Component requirements to meet those needs, citing the IEC documents for details

### DEFINITION OF THE PROJECT

First the project type must be selected:

- **EN 50173-2:** Office premises
- **EN 50173-3:** Industrial premises
- **EN 50173-4:** Single tenant homes
- **EN 50173-5:** Data centers

The **EN 50173-6:** Distributed building services, may also be added as part of the project requirements if the cabling infrastructure covers not only cabling for information technology but also building services.

### DESIGN AND INSTALLATION

These following 4 standards are required for compliance:

- **EN 50174-1:** Installation specifications and quality assurance
- **EN 50174-2:** Planning and installation implementation
- **EN 50174-3:** Installation planning and practices outside buildings
- **EN 50310:** Telecommunications bonding networks for buildings and other structures

Indeed, the system must be installed properly, and the bonding network needs to be adapted.

### TESTING

Testing is mostly absent or obsolete in the CENELEC documents. So testing should follow the same documents as ISO/IEC: **IEC 61935-1, ISO/IEC 14763-3, and ISO/IEC 14763-4.**

## DIAGRAM

The diagram of compliance is the following:

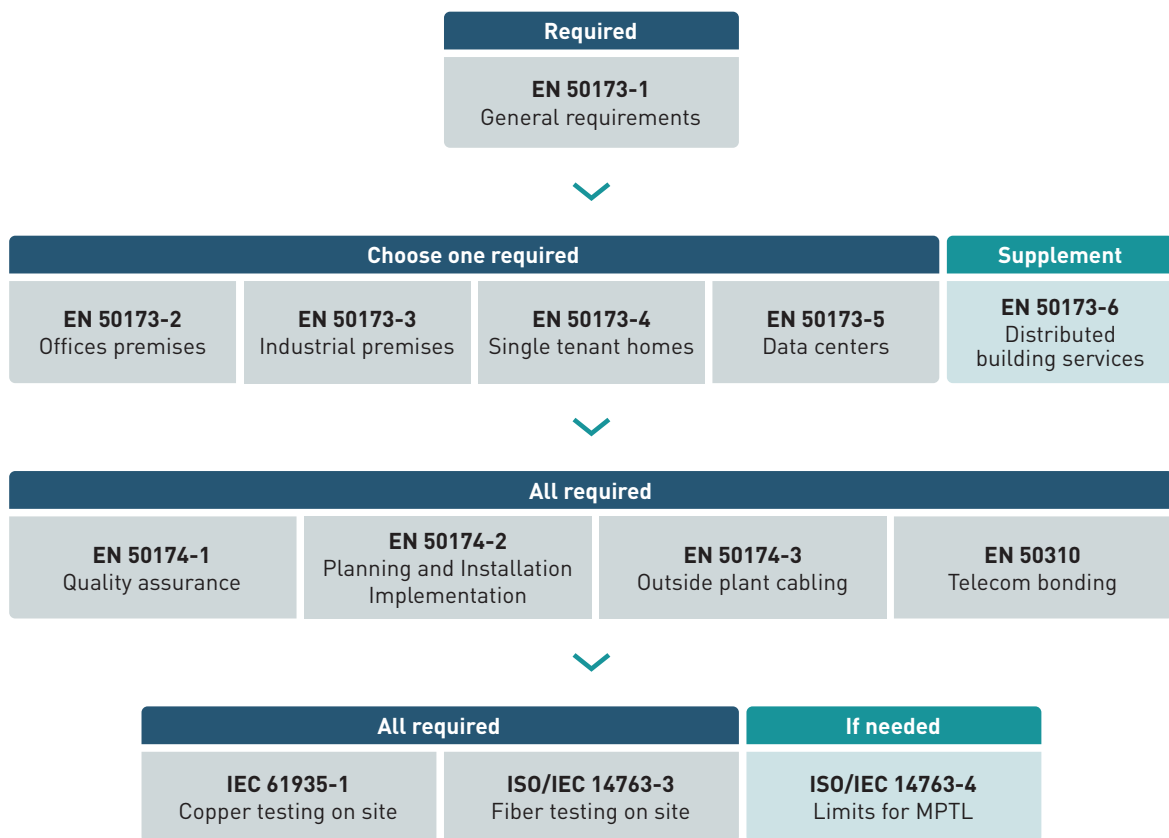

## ANSI/TIA 568 series

### GENERAL INFORMATION

The ANSI/TIA 568 series is the North American standard for generic cabling for customer premises. It is also similar to ISO/IEC 11801 series but with some variations in the structure and details of performance. It is also linked to the IEC standards for copper inter-operability and reliability as well as for fiber performance and testing.

### GENERAL REQUIREMENTS

The general architectures are found in the ANSI/TIA 568.0. The performances are in the:

- **ANSI/TIA 568.2:** Balanced cabling channels and links performance
- **ANSI/TIA 568.3:** Fiber cabling channels and links performance
- **ANSI/TIA 568.4:** Coaxial cabling channels and links performance

These include the component requirements to meet those needs, citing the IEC documents for details of reliability and inter-operability.

### DEFINITION OF THE PROJECT

The ANSI/TIA documents have the following premise definitions:

- **ANSI/TIA 568.1:** Commercial buildings
- **ANSI/TIA 1005:** Industrial premises
- **ANSI/TIA 570:** Residential
- **ANSI/TIA 942:** Data centers
- **ANSI/TIA 1179:** Healthcare
- **ANSI/TIA 4966:** Educational

The **ANSI/TIA 862:** Intelligent building systems may also be added as part of the project requirements if the cabling infrastructure covers not only cabling for information technology but also building services.

### DESIGN AND INSTALLATION

These following 4 standards are required for compliance:

- **ANSI/TIA 569:** Pathways and spaces
- **ANSI/TIA 606:** Administration
- **ANSI/TIA 758:** Outside plant cabling
- **ANSI/TIA 607:** Telecommunications bonding networks

Indeed, the system must be installed properly, and the bonding network needs to be adapted.

### TESTING

Copper testing limits are found in the **ANSI/TIA 568-2**, but the equipment requirements and the measurement methods are in the ANSI/TIA 1152.

Fiber testing is defined in the **ANSI/TIA 526-7** and **ANSI/TIA 526-14**. However, those are created from the **IEC 61280** series, which are also the base for the **ISO/IEC 14763-4** document.

The main concern of the ANSI/TIA documents is the lack of mandatory use of reference grade connectors for testing. The use of standard connectors leads to an uncertainty too high to ensure performance. So although there are currently available ANSI/TIA fiber testing documents, Legrand requires the use of reference cords for fiber testing, and therefore recommends the use of the **ISO/IEC 14763-3** standard, even for ANSI/TIA 568 compliance.

## DIAGRAM

The diagram of compliance is the following:

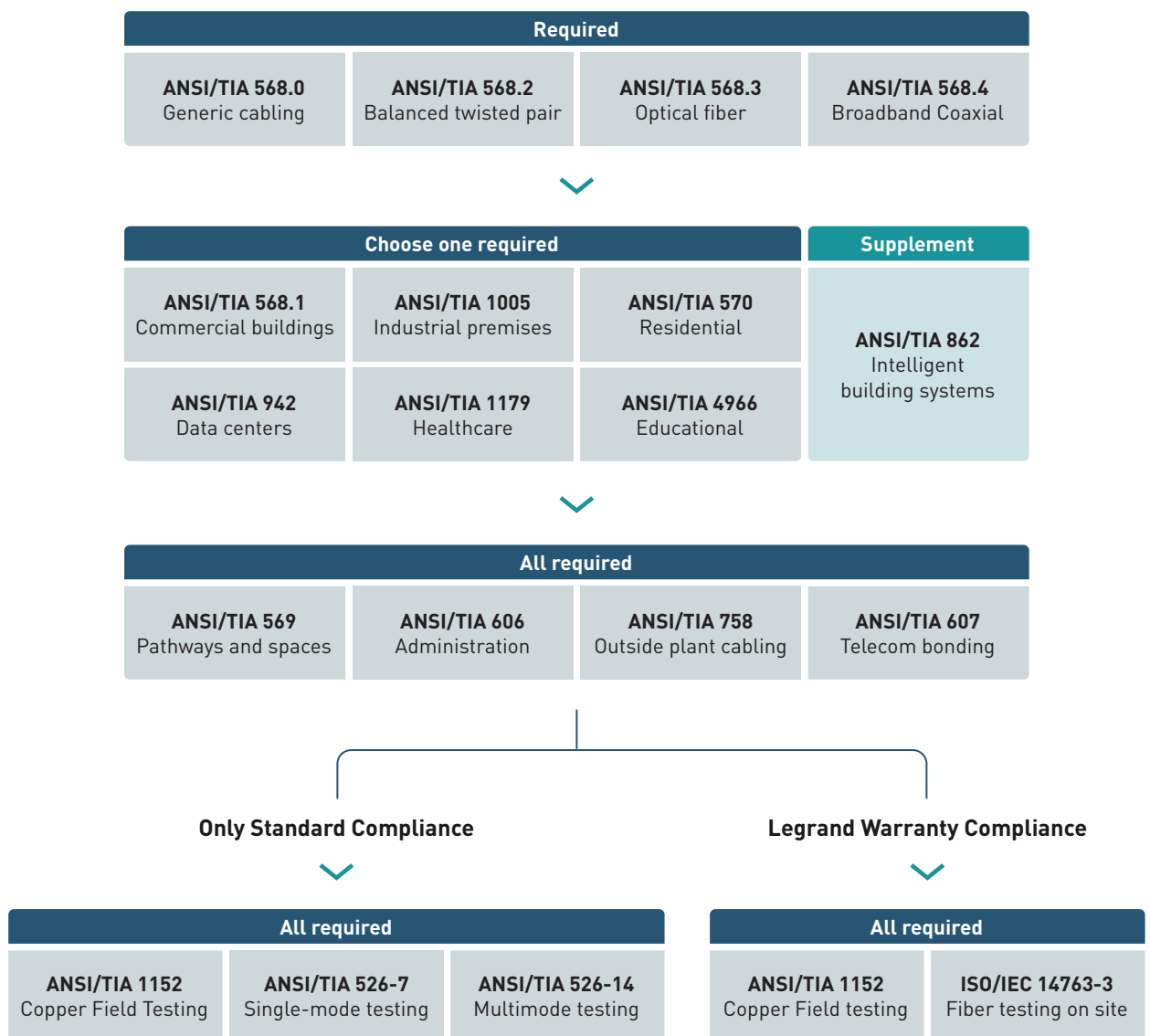

## Performance and architecture

Within customer premises, the importance of the cabling infrastructure is similar to that of other fundamental building utilities such as heating, lighting and mains power. As with other utilities, interruptions to service can have a serious impact. Poor quality of service due to lack of design foresight, use of inappropriate components, incorrect installation, poor administration or inadequate support can threaten an organization's effectiveness.

The standards for structured cabling systems provide:

- a) users with an application-independent generic cabling system capable of supporting a wide range of applications.
- b) users with a flexible cabling scheme making modifications both easy and economical.
- c) building professionals (for example, architects) with guidance allowing the accommodation of cabling before specific requirements are known; that is, in the initial planning for either new construction or refurbishment.
- d) industry and application standardization bodies with a cabling system which supports current products and provides a basis for future product development.

Such standards are, for example, ISO/IEC 11801 series, CENELEC 50173 series, ANSI/TIA 568 series.

They specify a multi-vendor cabling system which can be implemented with material from single and multiple sources, and related to:

- a) standards for cabling components developed by committees, for example copper cables and connectors as well as fiber optic cables and connectors.
- b) standards for the installation and operation of information technology cabling as well as for the testing of installed cabling (see Clause 2 and bibliography).
- c) applications such as those developed by study groups of IEEE 802,
- d) planning and installation standards which take into account the needs of specific applications for the configuration and the use of cabling systems on customer premises.

### ► FIBER OPTIC

In fiber, the following are recognized in the standards:

| Type        |      | Comments   |
|-------------|------|--|
| Multimode   | OM1  | Obsolete 62.5micron fiber. No longer recognized                                    |
|             | OM2  | Legacy 50micron fiber. No longer recommended                                       |
|             | OM3  | Original fiber designed for 10Gbps. Minimal recommended fiber                      |
|             | OM4  | Provides the same applications as OM3, but for longer distances                    |
|             | OM5  | New fiber optimized for multiple wavelengths (WDM) for new and future applications |
| Single-mode | OS1a | Indoor single-mode fiber   |
|             | OS2  | Outdoor single-mode fiber  |

In general, although it supports legacy applications to longer distances, OM4 is installed for short links up to 100m for current applications, while OM5 is installed to allow a wider recent and future application compatibility.

For long distance, OS1a/OS2 is used depending on the environment.



► **COPPER**

In copper, the following are recognized:

| ANSI/TIA    |             | ISO/IEC and CENELEC |          |
|-------------|-------------|---------------------|----------|
| Components  | Systems     | Components          | Systems  |
| Category 3  | Category 3  | Category 3          | Class C  |
| Category 5e | Category 5e | Category 5          | Class D  |
| Category 6  | Category 6  | Category 6          | Class E  |
| Category 6A | Category 6A | Category 6A         | Class EA |
|             |             | Category 7          | Class F  |
|             |             | Category 7A         | Class FA |
| Category 8  | Category 8  | Category 8.1        | Class I  |
|             |             | Category 8.2        | Class II |

However, for new installations, only Cat. 6 and better can be used for horizontal cabling, while only Cat. 6A and better can be used for data centers.

Categories 7, 7A and 8.2 are not recognized in ANSI/TIA standards since they do not use the universal RJ45 connector but rather 2 alternative non-compatible connectors that are not existing on active equipment. Legrand recommends not using those solutions as the global market share of less than 1% (source BSRIA) proves the lack of interest of the industry.

These Categories allow the following applications:

|            | Class D (Cat.5e)        | Class E (Cat.6)         | Class EA (Cat.6A)       | Class I (Cat.8) |
|------------|-------------------------|-------------------------|-------------------------|-----------------|
| 1000Base-T | 100m                    | 100m                    | 100m                    | 100m            |
| 2.5Gbase-T | Possible <sup>(1)</sup> | Possible <sup>(1)</sup> | 100m                    | 100m            |
| 5Gbase-T   | Possible <sup>(1)</sup> | Possible <sup>(1)</sup> | 100m                    | 100m            |
| 10Gbase-T  | N/A <sup>(3)</sup>      | Possible <sup>(2)</sup> | 100m                    | 100m            |
| 25Gbase-T  | N/A <sup>(3)</sup>      | N/A <sup>(3)</sup>      | Possible <sup>(4)</sup> | 30m             |
| 40Gbase-T  | N/A <sup>(3)</sup>      | N/A <sup>(3)</sup>      | Possible <sup>(4)</sup> | 30m             |

<sup>(1)</sup> Follow ISO/IEC TR 11801-9904 or TIA TSB 5021 to evaluate possibility on installed links. Distance will depend on many factors

<sup>(2)</sup> Follow ISO/IEC TR 24750 or TIA TSB 155-A to evaluate possibility on installed links. Distance will depend on many factors

<sup>(3)</sup> Not Available

<sup>(4)</sup> Follow ISO/IEC TR 11801-9905 to evaluate possibility on installed links. Distance will depend on many factors

## HORIZONTAL CABLING TOPOLOGIES

The standards recognize 2 main types of RJ45 copper connectors:

- The Fixed Connector: this is the female, also called a jack, that would be found in the patch panel or in the outlet
- The Free Connector: this is the male, also called a plug, that is used in cords

Until recently, a fixed cable of the Permanent Link could only be terminated on fixed connectors. This allowed testing of the permanent part of the cabling. Cords could then be connected on both sides to create a Channel to allow connection of the equipment.

Below is the basic configuration.

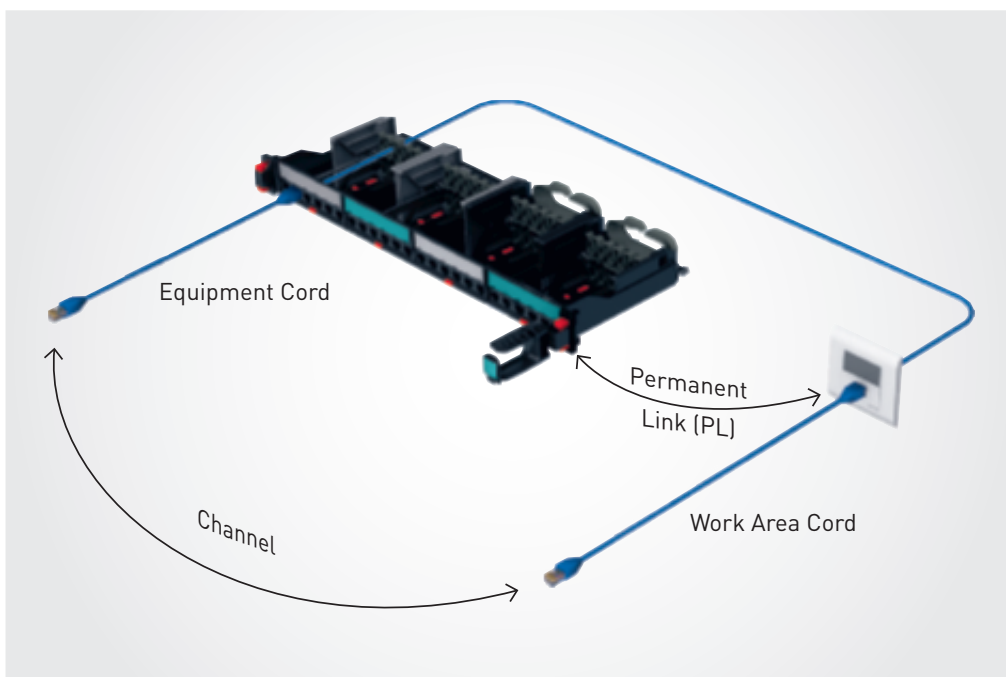

To provide better flexibility, the Channels were allowed up to 4 connectors as shows in the diagram below:

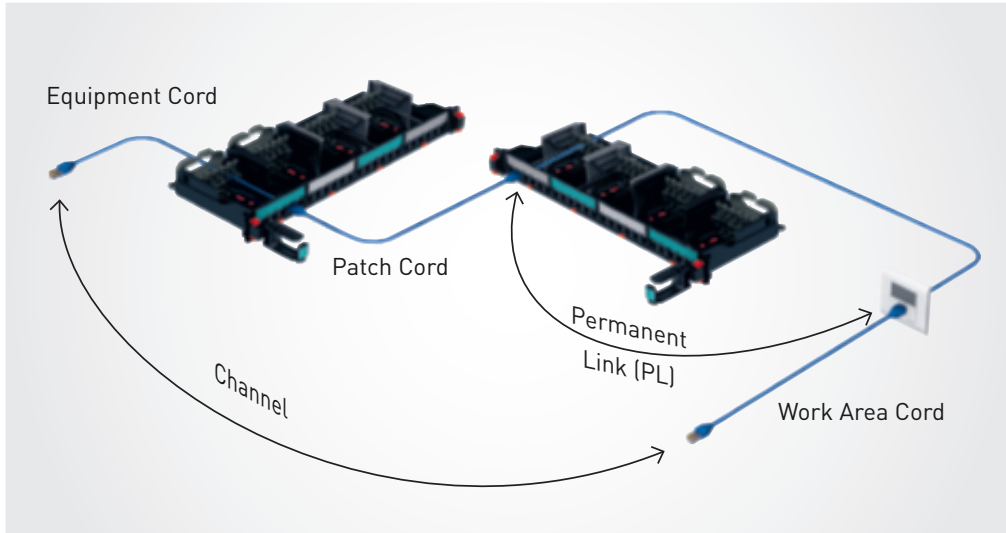

But they were never allowed fewer than the 2 connectors in the basic configuration.

The evolution of technologies has led to a growth of devices connected semi-permanently. This is generally in the false ceiling, and a connection is always done by a professional, rather than by anyone for typical outlets. Examples of such devices are Wi-Fi access points and IP cameras.

This leads to questions whether the mandatory outlet is justified: why not avoid it and connect a plug (free connector) at the end of the cable to directly attach the end device? This is called the Modular Plug Terminated Link (MPTL) and has been recently added as a recognized solution in the standards. Below is a diagram of an MPTL:

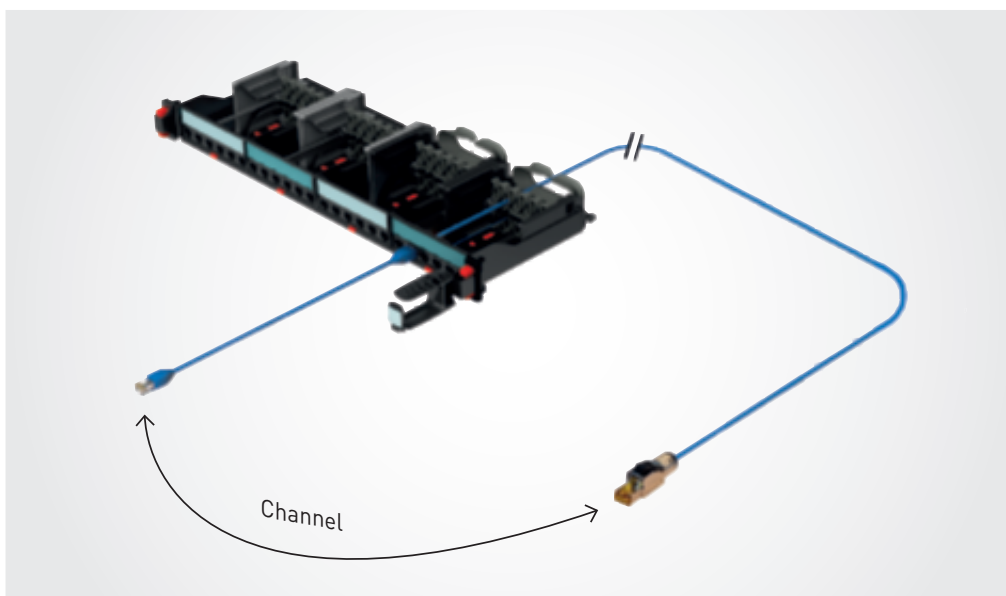

The MPTL requires a specific plug (free connector) of the same Category of the link. In exchange for lowering the flexibility which is not required in such application, it provides an increased reliability with fewer products, less space required, simplified compliance to fire reaction requirements, and last but not least, a cost saving.

### Legrand field installable plugs for MPTL



Cat. 5e & Cat. 6 UTP  
RJ 45 field plugs



Cat. 5e & Cat. 6 FTP  
RJ 45 field plugs

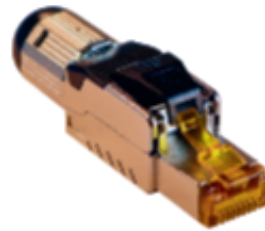

Cat. 6A STP toolless  
RJ 45 field plug

Caution must be used when testing such links. It is not a Permanent Link and is not a Channel. It must be tested as an MPTL with the correct adaptors and test limits.

For certification of a new cabling, only Permanent Link, and now MPTL, are recognized.

Below is the diagram of the Permanent Link testing:

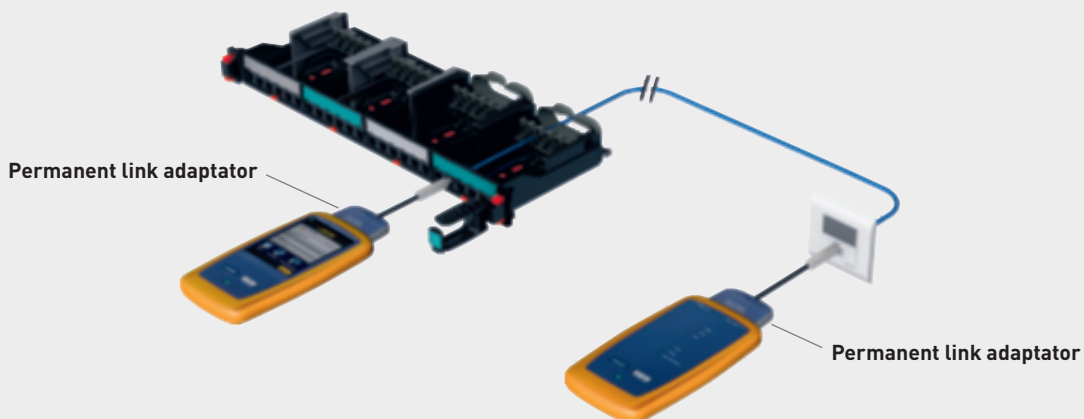

Below is the diagram of the MPTL testing:

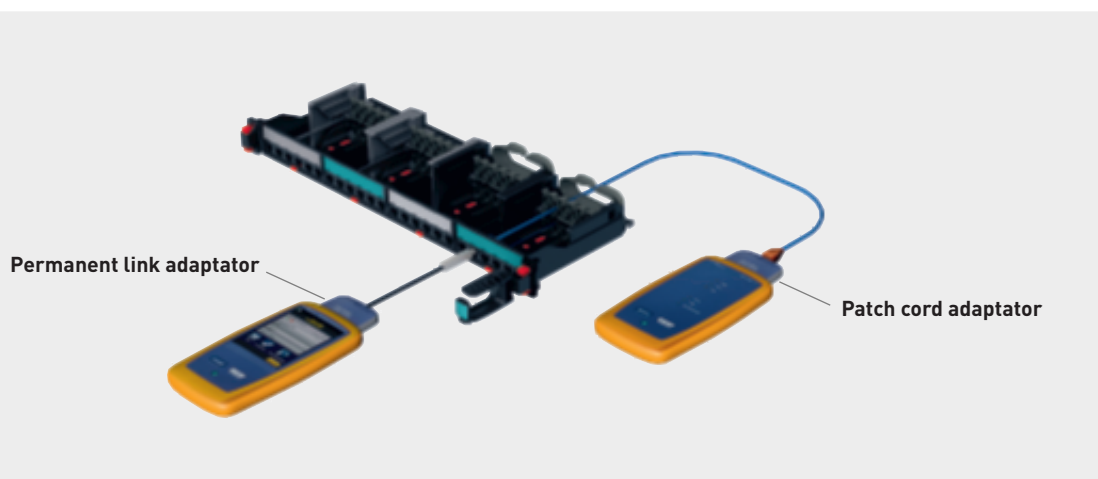

Channel can be tested for verification only, before connection of the active equipment, but it is not a certification test as it's linked to the cords used.

---

## CONCLUSION

Structured cabling standards are intended to provide interoperability and flexibility in the communications infrastructure. Since technologies evolve, so do standards.

Customers should always consider using the latest products for the best life expectancy of the infrastructure.

They should also consider the recent architectures to provide solutions best adapted to their needs, such as the MPTL extremely well adapted for devices connected semi permanently.

# Fiber considerations when migrating to 100 Gigabit Ethernet and higher

Multimode fiber systems have been the most cost-effective fiber solution to use in the data center because the transceivers are much less expensive than single-mode transceivers. Multimode transceivers use a vertical cavity surface emitting laser (VCSEL) light source, which is easy to manufacture and package. Multimode fiber systems have a shorter reach than single-mode systems, however most distances are less than 150 m; surveys have shown that more than 80% of data centers extend to 100 m or less. Although single-mode cable is less expensive, after factoring in the total system cost of multimode versus single-mode, multimode is still much less expensive.

Some common approaches used in data centers are summarized in Table 6. Each approach uses short-wavelength (850 nm) transmission over multimode fiber.

The fiber system should be designed around OM3 or better MMF if there are plans to support applications beyond 10 Gbps.

OM3 supports 10 GbE up to 300 m, but only supports 40 GbE up to 100 m. OM3 supports the 100GBASE-SR10 PMD up to 100 m but only supports 100GBASE-SR4 up to 70 m so that is another important consideration. OM4 supports 10 GbE up to 400 m, but only supports 40 GbE up to 150 meters. OM4 supports the 100GBASE-SR10 PMD up to 150 m but only supports 100GBASE-SR4 up to 100 m.

If planning to support 100 GbE and higher in the future, the channel cannot be designed for the maximum distances over which 10G can be supported. Always design for the application that has the most stringent requirements (usually the fastest data rates) even if the application is a future installation.

In addition to selecting the type of fiber, there are several other important considerations when selecting components for a fiber optic cabling system. These include channel insertion loss, polarity and alignment pins.

## Channel Insertion Loss/Loss Budget

The channel insertion loss is made up of the insertion loss (IL) of the cable, specified as decibels per kilometer (dB/km), the insertion loss of all mated connector pairs and the insertion loss of splices in that channel. As can be seen in the Table 7, as the data rate increases from 10 Gbps to 40/100 Gbps, the total channel insertion loss or loss budget decreases noticeably.

**Table 6: Common Data Center Approaches Using Short Wavelength Transmission**

| Data rate (Gbps) | IEEE standard     | Fiber pairs | Wavelengths |
|------------------|-------------------|-------------|-------------|
| 25               | Ratified Standard | 1           | 1           |
|                  | Ratified Standard | 4           | 1           |
| 40               | Non-Standard      | 1           | 2           |
|                  |                   | 1           | 4           |
| 50               | Ratified Standard | 1           | 1           |
|                  | Ratified Standard | 10          | 1           |
| 4                |                   | 1           |             |
| 2                |                   | 1           |             |
| 1                |                   | 4           |             |
| 100              | Non-Standard      | 1           | 2           |
|                  |                   | 1           | 1           |
| 200              | Ratified Standard | 4           | 1           |
|                  | Draft Standard    | 2           | 1           |
| 400              | Ratified Standard | 4           | 2           |
|                  |                   | 16          | 1           |
|                  |                   | 8           | 1           |
|                  | Draft Standard    | 4           | 1           |

**Table 7: Maximum Channel Insertion Loss for short wavelengths applications**

|  | Application               | Fiber type | Maximum distance | Maximum channel loss |
|--|---------------------------|------------|------------------|----------------------|
| 2-core applications<br>LC duplex or equivalent | 10GBASE-SR                | OM3        | 300m             | 2.6dB                |
|  |                           | OM4/OM5    | 400m             | 2.6dB                |
|  | 25GBASE-SR                | OM3        | 70m              | 1.8dB                |
|  |                           | OM4/OM5    | 100m             | 1.9dB                |
|  | 40G-SWDM4 <sup>(1)</sup>  | OM3        | 240m             | 2.1dB                |
|  |                           | OM4        | 350m             | 2.5dB                |
|  |                           | OM5        | 440m             | 2.5dB                |
|  | 50GBASE-SR                | OM3        | 70m              | 1.8dB                |
|  |                           | OM4/OM5    | 100m             | 1.9dB                |
|  | 100G-BIDI <sup>(1)</sup>  | OM3        | 70m              | 1.8dB                |
|  |                           | OM4        | 100m             | 1.9dB                |
|  |                           | OM5        | 150m             | 2.0dB                |
| 100G-SWDM4 <sup>(1)</sup>                      | OM3                       | 70m        | 1.8dB            |                      |
|  | OM4                       | 100m       | 1.9dB            |                      |
|  | OM5                       | 150m       | 2.0dB            |                      |
| 4-core applications<br>LC duplex or equivalent | 100GBASE-SR2              | OM3        | 70m              | 1.8dB                |
|  |                           | OM4/OM5    | 100m             | 1.9dB                |
| 8-core applications<br>Typically MPO           | 40GBASE-SR4               | OM3        | 100m             | 1.9dB                |
|  |                           | OM4/OM5    | 150m             | 1.5dB                |
|  | 100GBASE-SR4              | OM3        | 70m              | 1.8dB                |
|  |                           | OM4/OM5    | 100m             | 1.9dB                |
|  | 200GBASE-SR4              | OM3        | 70m              | 1.8dB                |
|  |                           | OM4/OM5    | 100m             | 1.9dB                |
|  | 400G-BD4.2 <sup>(1)</sup> | OM3        | 70m              | 1.8dB                |
|  |                           | OM4        | 100m             | 1.9dB                |
|  |                           | OM5        | 150m             | 2.0dB                |
|  | 400GBASE-SR4.2            | OM3        | 70m              | 1.8dB                |
|  |                           | OM4        | 100m             | 1.9dB                |
|  |                           | OM5        | 150m             | 2.0dB                |
| 16-core applications<br>Typically MPO          | 400GBASE-SR8              | OM3        | 70m              | 1.8dB                |
|  |                           | OM4/OM5    | 100m             | 1.9dB                |
| 20-core applications<br>Typically MPO          | 100GBASE-SR10             | OM3        | 100m             | 1.9dB                |
|  |                           | OM4/OM5    | 150m             | 1.5dB                |
| 32-core applications<br>Typically MPO          | 400GBASE-SR16             | OM3        | 70m              | 1.9dB                |
|  |                           | OM4/OM5    | 100m             | 1.9dB                |

<sup>(1)</sup> Not an IEEE standard. Application available as multi-source agreement

Understanding the impact of each component in the channel loss budget is extremely important when selecting cables and connectors. Often, the cable attenuation performance and bandwidth drive the design of the channel. The impact that a connector can have on the total channel budget can be significant.

The figure below shows the total loss budgets for a 100 m channel at different data rates common to current Ethernet applications. As data rates progress from 100 Mbps Ethernet-based systems to today's 10 Gbps Ethernet-based systems, the fiber optic loss budgets have shrunk considerably from 11 dB to 2.6 dB. 40/100 Gbps Ethernet systems have an even smaller budget of 1.9 dB when using OM3 or 1.5 dB when using OM4.

**Total Channel Insertion Loss by Application**

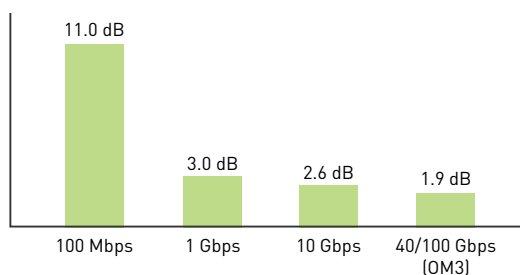

If we look at two channel insertion loss budget examples for 2 and 3 mated pairs, including the cable loss for a 100 m link at 850 nm, the importance of connector loss is apparent. Using the standard loss for a multimode fiber cable (OM3/OM4, 850 nm) of 3 dB/km (ISO/IEC 11801 3rd Edition-Q2 2017) and an average of 0.50 dB loss per mated connector pair (standards allow up to a maximum 0.75 dB loss and up to 4 connections), the calculated loss for a 100 m channel with 2 mated connector pairs is 1.35 dB  $[(3.5\text{dB/km} * 0.1\text{km}) + (0.5 * 2)]$ . Applied to the loss budgets, as shown in the figure below, this is not significant for 100 Mbps systems. However, the insertion loss takes up a little more than half of the 10G budget and almost three-quarters of the 40/100 Gbps budget.

**Channel Insertion Loss In a 100 M Channel with 2 Mated Connector Pairs**

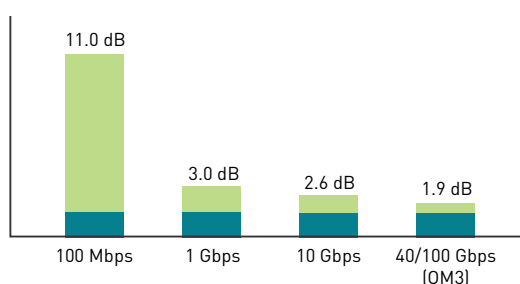

■ Margin between the link loss and the application limit  
■ Link insertion loss (1.35 dB)

If we look at a 3-connector-pair channel, the loss budget rises to 1.85 dB  $[(3.5\text{dB/km} * 0.1\text{km}) + (0.5 * 3)]$ , as shown in the figure below. This is more than 70% of the 10 Gbps budget and almost the entire 40/100 Gbps budget. This would exceed the loss budget using OM4 for 150 m, which is 1.5 dB because of the longer distance, proving the insertion loss of a connector is very important.

**Channel Insertion Loss In a 100 M Channel with 3 Mated Connector Pairs**

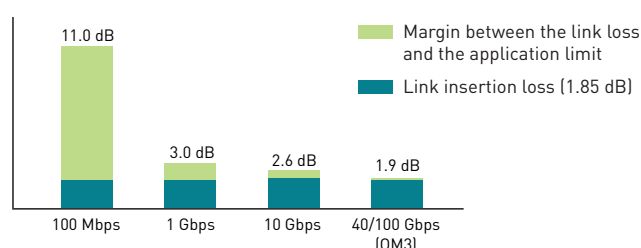

It is important to consider the trade-off. If the IL of one component can be reduced, there will be room for extra loss in another component. For example, if using OM4 at only 100 m instead of 150 m, the loss of the cable will be less because IL is directly related to distance (dB/km). This can make room for more mated connector pairs. However, all of the IL gain can easily be negated with inferior connector components.

### Polarity

Don't forget to plan for the correct polarity. Maintaining correct polarity guarantees an optical path from the transmit port of one device to the receive port of another device, known as the polarity flip. There are several different methods to maintain polarity, but the different methods may not be interoperable. There are three methods depicted in the standard ISO/IEC 14763-2 "planning and installation"; methods A, B and C. There are other proprietary methods used by various manufacturers.

Each method requires a specific combination of components to maintain polarity. Assuming duplex signaling, using an MPO backbone cable, cassettes and patch cords, the following list shows the component options that are used in specific combinations for each of the polarity methods.

The options for components are:

- MPO-to-MPO backbone cables: Type A, B or C
- MPO-to-LC cassettes: Method A or Method B
- Patch cords: Type A-to-A or Type A-to-B

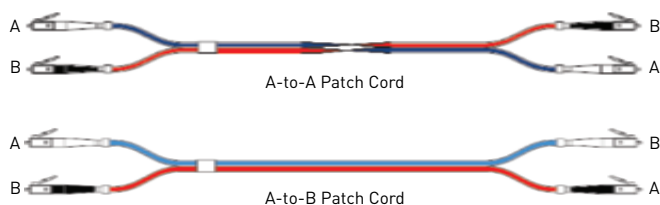

# Fiber considerations when migrating to 100 Gigabit Ethernet and higher

For example, with duplex signaling, a Method A polarity scheme uses a Method A cassette, Type A trunk cable and a type A-to-B patch cord on one end of the channel and a type A-to-A patch cord on the other end. The transmit to receive flip occurs in the patch cord at one end. Method B uses a Method B cassette and trunk cable and an A-to-B patch cord at each end because the flip occurs in the cassette and trunk cable. Method C uses a Method A cassette with a Type C trunk cable and A-to-B patch cords at each end. The flip occurs in the trunk cable only.

Polarity becomes more complicated when migrating to 40/100 GbE because parallel transmission replaces duplex transmission. Parallel fiber optic links integrate multiple transmitters in one transmitter module, multiple fibers in fiber array connectors and multiple receivers in one receiver module. Multiple transmitters and receivers may also be integrated together in a transceiver module.

The three methods, A, B and C, are expanded in the ISO/IEC 14763-2 standard to include links that use parallel signaling in one row. Array connectors are keyed to maintain polarity. A keyed MPO connector is shown in the figure below.

**MPO Plug Fiber Positions Looking at the Ferrule End with Key Up**

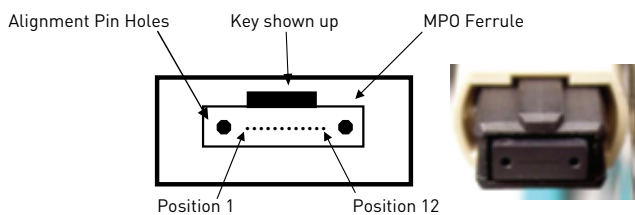

## Alignment pins

When mating connector plugs that use alignment pins, like the MPO connector, it is critical that one plug is pinned and the other plug is unpinned. Because all known transceivers that accept MPO plugs are pinned, they accept only unpinned plugs.

**MPO Connector With Pins Installed**

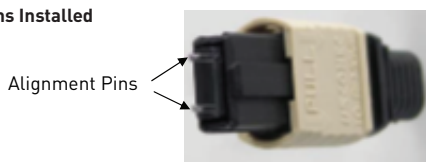

The pinned connector is typically located inside the panel to help protect the pins from being damaged (i.e. the fixed connector is pinned and the connector that is frequently removed and handled is unpinned). For example, cassettes are typically pinned and trunk cables are typically unpinned.

**Consult the manufacturer since there may be exceptions required for your design.**

**If not properly cleaned, alignment pins can collect debris around the pins, resulting in the two components not mating correctly.**

## A new fiber

The wideband MMF TIA standard was approved for publication in the middle of 2016. The standard specifies high bandwidth 50  $\mu\text{m}$  core diameter/125  $\mu\text{m}$  cladding diameter, laser-optimized optical fiber that is optimized to enhance performance for single wavelength or multi-wavelength transmission systems with wavelengths in the vicinity of 850 nm to 950 nm. The actual operating band is from 850 nm to 953 nm. The effective modal bandwidth (EMB) for this new fiber is specified at the lower and upper wavelengths: 4700 MHz•km at 850 nm and 2470 MHz•km at 953 nm. ISO/IEC has assigned the OM5 designation for this type of fiber and it was ratified under IEC 60793-2-10 type A1a.4.

This is a significant standard for multimode fiber because it makes wavelength division multiplexing (WDM) possible over multimode fiber. Since the fiber is optimized for short wavelengths, the wavelength division multiplexing used over multimode fiber is commonly called short wavelength division multiplexing (SWDM). Up until now, WDM has only been used with single-mode fiber. WDM is important because it is one of four ways to increase the data rate: WDM, parallel transmission with multiple fibers, increased modulation and using multi-level coding.

To show how this new standard can influence fiber optic plant for current and in-progress Ethernet standards refer to Table 8. The current 40 GbE (40GBASE-SR4) standard, using short wavelength over multimode fiber (MMF), uses a channel rate of 10 Gbps with eight fibers; four fibers for transmission and four fibers for reception. Using OM5 that supports four wavelengths (in effect four channels) the four transmit fibers are reduced to one fiber, as are the receive fibers. The fiber optic cable plant is reduced from eight fibers to two. 100GbE is an even better example because the original standard released in 2010 (100GBASE-SR10) required a total of 20 fibers, 10 transmit and 10 receive, using a 10Gbps channel rate. A new 100GbE standard (100GBASE-SR4) was published in 2015 specifying a 25Gbps channel rate which allowed the fiber count to be reduced to a total of eight fibers; the same fiber count as 40GbE. This is an example of how increased modulation reduces the fiber count. Using SWDM with the new OM5 can reduce the fiber optic plant to two fibers for 100 GbE using a 25 Gbps channel rate. With the 50Gbps channel rate, it can allow 200Gbps on 2 cores, and with the future 100Gbps channel rate, it could allow 400Gbps on 2 cores.

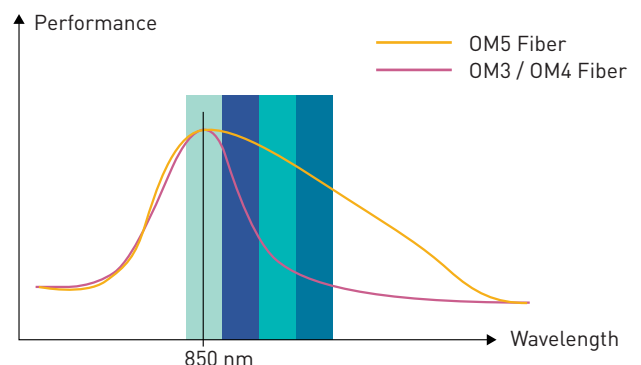



As was mentioned, Phase I of the 400GbE (IEEE 802.3bs) standard ratified transmission over multimode using parallel transmission with a channel rate of 25 Gbps. This requires a total of 32 fibers. Employing SWDM over OM5 reduces the fiber count to 8 fibers, 25% of the number of fibers required in Phase I.

## What's coming?

IEEE 802.3 has provided the 50Gbps channel rate, allowing 100Gbps on 4 cores and 200Gbps on 8 cores using parallel optics, and later on 400Gbps on 16 cores.

IEEE 802.3db working group has now started work on the 100Gbps channel rate which will be used to create the following applications:

- 100Gbps on 2 cores
- 200Gbps on 4 cores
- 400Gbps on 8 cores

These are specifically designed for end-of-row cabling, with 2 distances: 50m and 100m variations.

In the meantime, a new architecture as developed in the active equipment: Breakout mode. This involves using a single MPO connection in a switch, which then is split into multiple connections with duplex connectors. The advantages are multiple:

- Fewer switch ports needed for a given number of devices connected.
- Fewer ports needed on the fiber patching
- Fewer cords needed for patching
- Lower connector attenuation than when using parallel-to-duplex (MPO-to-LC) cassettes on both sides.

An example is a current 200G port that can breakout into 4 duplex ports of 50Gbps each.

These new IEEE 802.3db applications are specifically designed to allow the breakout mode, for example allowing a 400Gbps port to breakout into 4 ports of 100G.

Example of cabling for Breakout mode:

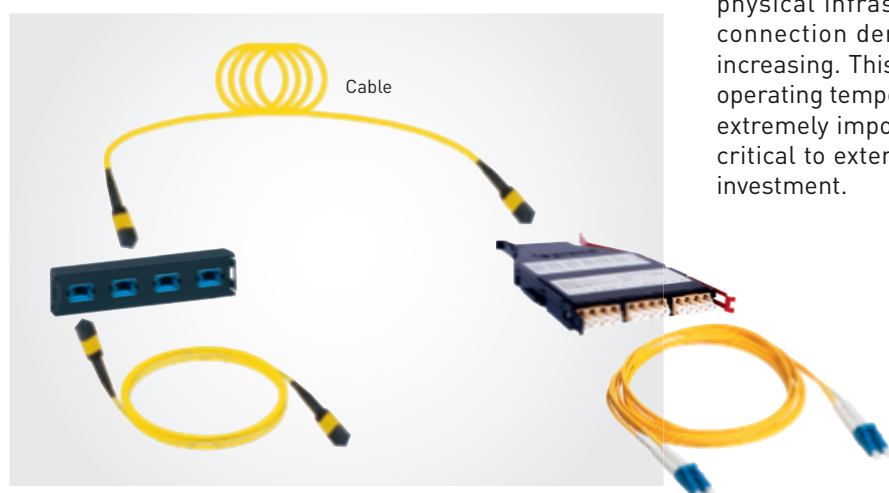

This leads to a new cabling architecture, where instead of having the same connectors on both ends, would have an MPO/MTP connector at one end, and duplex connectors of type LC or equivalent on the other end. This architecture can allow the following evolutions on multimode fiber:

- 40Gbps to 4 x 10Gbps
- 100Gbps to 4 x 25Gbps
- 200Gbps to 4 x 50Gbps

## Conclusion

Before selecting a product for your data center design, establish the fastest application your structured cabling will need to support. Multimode fiber systems are more common than single-mode systems for short distances because they are more cost-effective. Selecting OM4 will provide longer-distance support or more connections over shorter distances compared to OM3. And selecting OM5 will additionally ensure compatibility for new SWDM applications that allow the increase of data rates without increasing the number of fibers needed.

The type of connector is determined by the transmission; LC for duplex transmission and MPO/MTP® for parallel transmission. And new architectures take advantage of the breakout mode, allowing the reduction of ports on the switches.

Channel insertion loss is the foundation for design, so consider high-performance, low-loss components.

You will also need to consider the polarity method to be used and then select the correct components to support that method. If using array connectors for parallel transmission, consider which components require pins and which do not. The best option is to work with the manufacturer to make sure the correct components are selected.

Don't forget to put as much thought into designing your physical infrastructure as the structured cabling. The connection density in switches, servers and routers is increasing. This means more cable to manage and higher operating temperatures, making properly managed airflow extremely important. The correct infrastructure design is critical to extend the life of the network and protect your investment.

# The next step in fiber connectors

Fiber connectivity has gone through a couple of evolutions. First generation in data networking were the SC and the ST connectors. The next generation, providing higher density, were the Small Form Factor (SFF) duplex connectors. This was our introduction to the LC connector. The MPO came later for supporting parallel transmission. There were other fiber connectors in both the 1st generation and SFF footprint, however the ones mentioned have become the most common in data networks.

Data center growth and transceiver design that requires a duplex optical connector with a smaller footprint, than the LC, are driving a 3rd generation of duplex connectivity—very small form factor (VSFF) optical fiber connectors. These new VSFF connectors include the CS, SN and MDC. All are a push-pull style to make insertion and extraction easier. The CS was developed as a replacement for the LC connector enabling higher density. The SN fiber connector provides increased density over the CS and enables breakout at the transceiver. The MDC connector supports the highest density of the three, supports breakout at the transceiver and enables simple polarity reversal in the field.

| Connector | Density in 1 RU (rack unit)   | Comparison  |
|-----------|-------------------------------|---|
| LC        | 72-duplex ports / 144 fibers  | Highest density available today                   |
| CS        | 168-duplex ports / 336-fibers | More than 2x LC density                           |
| SN        | 192-duplex ports / 384-fibers | Higher density than CS                            |
| MDC       | 216-ports / 432-fibers        | Highest density; 3x LC density; polarity reversal |

Along with these new VSFF connectors, new ways to breakout parallel to duplex transmission is becoming available. Traditionally, breakout from a higher to a lower data rate was done with a cassette or a harness. Cassettes make management easier but add two connections to the channel. Harnesses only add one connection however, they are more difficult to manage than patch cords. New solutions in the market are providing options that offer the advantages of the cassette and harness in one—breakout to patch cords for easy management with only one connection added.

The example shown breaks out an 8-fiber trunk to four MDC connectors. This provides very high density with only one connection in the channel. Yes, you can have your cake and eat it too! Use of the MDC connector makes polarity easily reversible without the need for special tools. Polarity can be changed for both multimode and single-mode, which is usually not possible because of the angled polish.

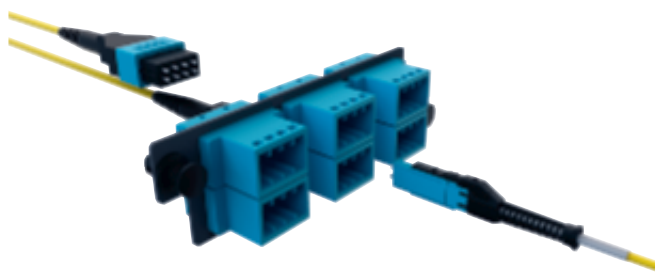

Historically, equipment has driven the adoption of new connectors. With new breakout options, like the one shown here, both connectivity and the equipment manufacturers will drive market adoption.

Knowing the right questions to ask is the key. Technology is always evolving, inspiring new ideas and ways to do things. Keeping up with changes can be challenging and time consuming. You don't need to know every option available; you just need to ask the right questions to select the best connectivity for your application. Nothing is "future-proof" but making the right connectivity decisions lengthens the life of the structured cabling through several generations of equipment.

# Cable fire ratings - Construction Projects Regulation (CPR) Applied to Structured Cabling

## What is the CPR?

The Construction Projects Regulation (CPR) is a European law published in 2011, with a classification ratified in 2016, to impose minimum fire performance to products installed permanently in buildings. It covers, among other items, the communications cables fixed in the building, but not the removable items such as patch cords and user cords. Vendors are required to comply since July 1st, 2017 and the fire rating must be identified on the cable packaging along with the CE mark. The associated declaration of performance (DoP) must be made available to customers.

The EU regulation enforcing the standard by law is applicable to all European Economic Area (E.E.A.) member states: Austria, Belgium, Bulgaria, Croatia, Cyprus, the Czech Republic, Denmark, Estonia, Finland, France, Germany, Greece, Hungary, Ireland, Italy, Latvia, Lithuania, Luxembourg, Malta, the Netherlands, Poland, Portugal, Romania, Slovakia, Slovenia, Spain, Sweden, the United Kingdom.

It also applies in the countries voluntarily participating to be part of the single market: Iceland, Liechtenstein, Norway and Switzerland. In addition, four other countries are E.U. candidates and in the process of incorporating EU legislation into national law: Montenegro, Macedonia, Serbia and Albania. Finally, Turkey is an associate member, voluntarily following EU regulations.

## Details of the CPR

The CPR now classifies cables according to the characteristics of flame propagation and heat release, as well as additional characteristics: smoke production, smoke acidity, and flaming particles. Then it also introduces various levels of conformity control over the results. As an example, a CPR classification

## Why do we care since we already have LSZH?

Previously, cables sold in Europe were classified in 2 types depending on their outer jacket:

- PVC: Poly Vinyl Chloride. A type of plastic that, in case of fire, usually burns very fast and emits large amounts of thick and irritating smoke. Translation: fire spreading quickly, people can't see the exit because of the smoke, and can't breathe because that smoke is burning their lungs.
- LSZH: Low Smoke Zero Halogens. The "Low Smoke" means that people should be able to still see in case of fire. Fluorine, Chlorine, Bromine, Iodine and Astatine are highly reactive in case of fire and are the principal irritating components of the cable sheaths. The "Zero Halogens" means avoiding them and thus cables are less irritating to the human lungs in case of fire.

The problem is that these terms imply only the type of material of the jacket, but not the conductor isolation material, and do not impose any actual fire resistance of the cable. Some manufacturers chose to comply with certain IEC fire rating tests, but those were insufficient and not mandatory.

A second issue was discovered more recently with less reputable suppliers: non-compliance. Some cables claimed to meet the ratings, but when tested they failed miserably. So, there was a necessity to also introduce a solution to guarantee the rating rather than simply rely on manufacturer claims.

is written "D<sub>CA</sub> s2 d2 a1". D<sub>CA</sub> is the Euroclass and "s2 d2 a1" are additional criteria.

The classification consists of 7 Euroclasses which define the fire reaction performance. Below is a table summarizing the classification:

### TESTING AND LEVEL OF CONTROL:

|                       |   | A <sub>CA</sub> | B1 <sub>CA</sub> | B2 <sub>CA</sub> | C <sub>CA</sub> | D <sub>CA</sub> | E <sub>CA</sub> | F <sub>CA</sub> |
|-----------------------|---|-----------------|------------------|------------------|-----------------|-----------------|-----------------|-----------------|
| Euro classification   | Gross heat of combustion                          | yes             |                  |                  |                 |                 |                 |                 |
|                       | Flame propagation                                 |                 | yes              | yes              | yes             | yes             | yes             | no              |
|                       | Heat release                                      |                 | yes              | yes              | yes             | yes             | no              | no              |
| Additional criteria   | Smoke production, flaming droplets, smoke acidity |                 | yes              | yes              | yes             | yes             | no              | no              |
| Control of compliance | Type Testing by independent lab                   | yes             | yes              | yes              | yes             | yes             | yes             | no              |
|                       | Production sampling by certification body         | yes             | yes              | yes              | yes             | no              | no              | no              |

# Cable fire ratings - Construction Projects Regulation (CPR) Applied to Structured Cabling

## EXPLANATION OF THE EUROCLASSES:

| Euroclass        | Reaction to fire                                    | Comments   |
|------------------|---|--|
| A <sub>CA</sub>  | Non combustible                                     | It is near-impossible to produce non-combustible communication cable.  |
| B1 <sub>CA</sub> | Various level of flame propagation and heat release | D <sub>CA</sub> is the lowest cable type with all aspect tested and certified by an independent laboratory. Higher classes offer improved resistance to flame propagation and heat release but their additional criteria could be identical. |
| B2 <sub>CA</sub> |   |  |
| C <sub>CA</sub>  |   |  |
| D <sub>CA</sub>  |   |  |
| E <sub>CA</sub>  | Minimum flame propagation testing                   | Heat release is not tested. Additional requirements are not tested, so the spread of fire is controlled, but the evacuation of people is limited due to toxic fumes. This is the first level of cable to require independent testing.        |
| F <sub>CA</sub>  | No testing  | Offers absolutely no guarantees. Should be avoided.  |

## DEFINITIONS OF THE ADDITIONAL CRITERIA:

| Smoke production | Performance  |
|------------------|--|
| s1               | Very low smoke production                          |
| s1a              | Very low smoke production and high transmittance   |
| s1b              | Very low smoke production and medium transmittance |
| s2               | Average smoke production                           |
| s3               | No performance guaranteed                          |

| Particles / Droplets | Performance                      |
|----------------------|----------------------------------|
| d0                   | No droplets / flaming particles  |
| d1                   | Low droplets / flaming particles |
| d2                   | No performance guaranteed        |

| Smoke acidity | Performance               |
|---------------|---------------------------|
| a1            | Very low smoke acidity    |
| a2            | Low smoke acidity         |
| a3            | No performance guaranteed |

These additional criteria are added after the letter of the Euroclass in order s, d, a. and they allow for more than 200 combinations. For obvious reasons, most will not exist, and only the most useful ones will be used.

It is important to understand that the lowest rating in each type means that the product actually does not meet the requirements.

The smoke production can impair visibility and restrict people from finding the exit. If the cable is compliant to "s1", then an additional test of transmittance measure exactly how far a person can see. This factor can be important in fire escape routes, but less in closed rooms where the exit is known.

The acidity is the primary danger in case of evacuation and is the main cause of death.as it seriously impairs breathing. However, it's only an important factor with large quantities of cables in area where people cannot exit rapidly.

The flaming particles pose two risks: spreading the fire to other areas and burning people nearby. So, when contained inside cable management, this aspect has far lower risk than with apparent cables.

## How to choose?

The European Union imposes the cables to comply with this classification, but it does not impose any specific requirement. This is the decision of each country and will depend on building types. Some countries have already defined their requirements, but for the others, the advice below can help designers make informed decisions.

If it were possible, all installations would use only the highest fire resistance possible. Unfortunately, there are always tradeoffs to obtain an optimal balance between safety, ease of installation and cost.

Euroclass A<sub>CA</sub> will most likely not exist in communication cables.

Euroclass B1<sub>CA</sub> and B2<sub>CA</sub> are generally limited to “protected” emergency exits. These are areas used strictly for emergency and with no burning material inside. The only cables entering this space are to connect fire safety equipment such as fire escape signs or fire detection. Any other cables crossing that space should be enclosed in a fire rated pathway.

Euroclass C<sub>CA</sub> is the first level to require regular product sampling by a certification body, so the cable not only has added cost of manufacturing but also cost of control. This can be justified for high density public areas, or when mandated by law.

Euroclass D<sub>CA</sub>, offers adequate reaction to fire with a certification of compliance from an independent lab. This is the most common cable.

At the bottom of the list, Euroclass F<sub>CA</sub> is not guaranteed for anything, and Euroclass E<sub>CA</sub>, although tested for fire propagation, is not tested for heat or for any additional criteria. These cannot be recommended, although E<sub>CA</sub> could be used where a very limited quantity of cables is installed as these would have a low impact in case of fire.

Then additional criteria must be decided. In Europe, the majority of cables are installed either in the false ceiling, in walls or in closed wall mount containment. This is an important aspect for selecting the right options. The smoke should be controlled but it's not so critical in most areas since there are already barriers.

We can generally see the D<sub>CA</sub> associated with the “s2”, and C<sub>CA</sub> and above associated with the “s1” requirement. The “s1a” and “s1b” are generally applied only in very specific contained fire exits and associated to the highest Euroclasses.

While the cables are not directly inside the user space, the particles have marginal influence on the ability for people to evacuate. These could have an impact in an open containment directly above a main exit corridor where flaming droplets could pose a threat, but in most cases, “d2” is perfectly acceptable. If the cables are crossing a critical area, the simplest is to enclose them in fire resistant containment for that area.

Acidity: it's obvious that a single cable enclosed in a conduit does not have the same effect as a bundle on an open cable tray in a corridor. The general market acceptance is that some acidity is tolerated for low quantity of cables in conduits in residential but is never allowed for any common areas or public buildings. “a1” is the only safe choice if acidity needs to be controlled.



# Cable fire ratings - Construction Projects Regulation (CPR) Applied to Structured Cabling

## Design

The CPR is a European regulation to categorize cables according to their reaction to fire. Each country in E.U. can define its own requirements for each type of building based on the classification provided.

In countries where no specification is imposed, it is up to the designers to lead the industry in providing secure installations, allowing people to safely exit building in case of fire.

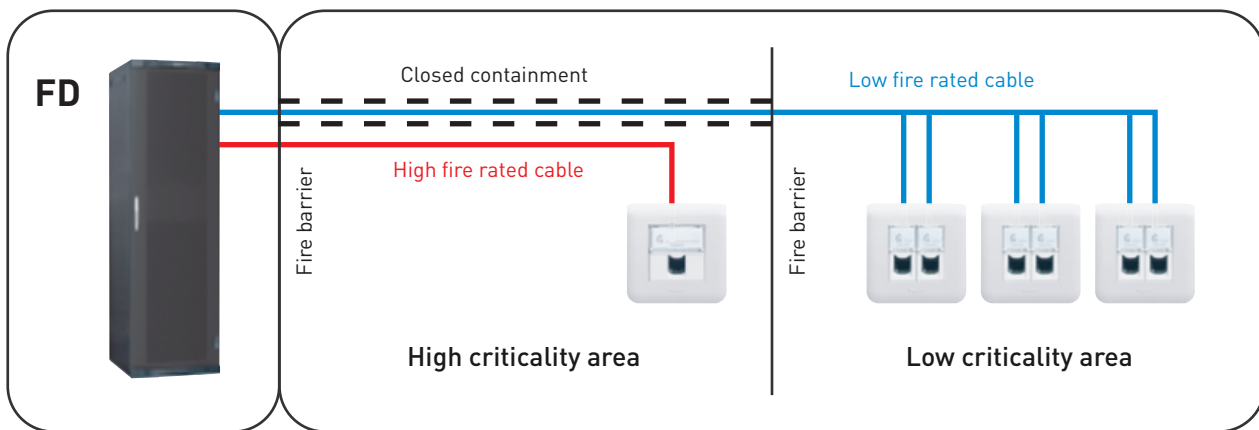

Unlike electrical cables, data cables cannot be spliced, so it's impossible to have a single circuit with various fire ratings according to areas crossed. It could seem simplest to always use the cable with the highest fire rating for the complete installation, but this will have significant impacts on cost and installation methods. The most practical solution is to choose the lowest acceptable rated cable for most of the project, then adapt to specific cases such as containment when crossing a sensitive area or specific cables only for certain needs. A smarter design can improve both costs and safety.

# PoE standards and architecture

## Standards

Applications converging over IP allow communications to occur over Ethernet, a common standard which has evolved to support both data and low voltage power over industry standard category cabling. Many of the applications mentioned previously are also leveraging devices that have become more power efficient. With these devices having lower power requirements, they are now able to be powered using low-voltage direct current (DC) over a single Ethernet cable.

The IEEE sets the standard for Power over Ethernet (PoE) which allows for the simultaneous transmission of data and low-voltage power over Ethernet cabling.

With the ratification of 4-pair PoE, 802.3bt, the latest IEEE standard allow up to almost 100 Watts of DC power to be delivered from the power source equipment alongside data transmissions in a single category cable.

## STANDARDS AND APPLICATIONS

| Organisation/standard               | Watts from power source equipment |
|-------------------------------------|-----------------------------------|
| IEEE 802.3af<br>2-pair PoE          | Up to 15.4 W                      |
| IEEE 802.3at<br>2-pair PoE+         | Up to 30 W                        |
| IEEE 802.3bt (Type 3)<br>4-pair PoE | Up to 60 W                        |
| IEEE 802.3bt (Type 4)<br>4-pair PoE | 90 W                              |



When considering a connected infrastructure design, it is important to start by determining the type of applications that will be implemented, both now and in the future, and then determine the power supply requirements needed to power the connected devices.

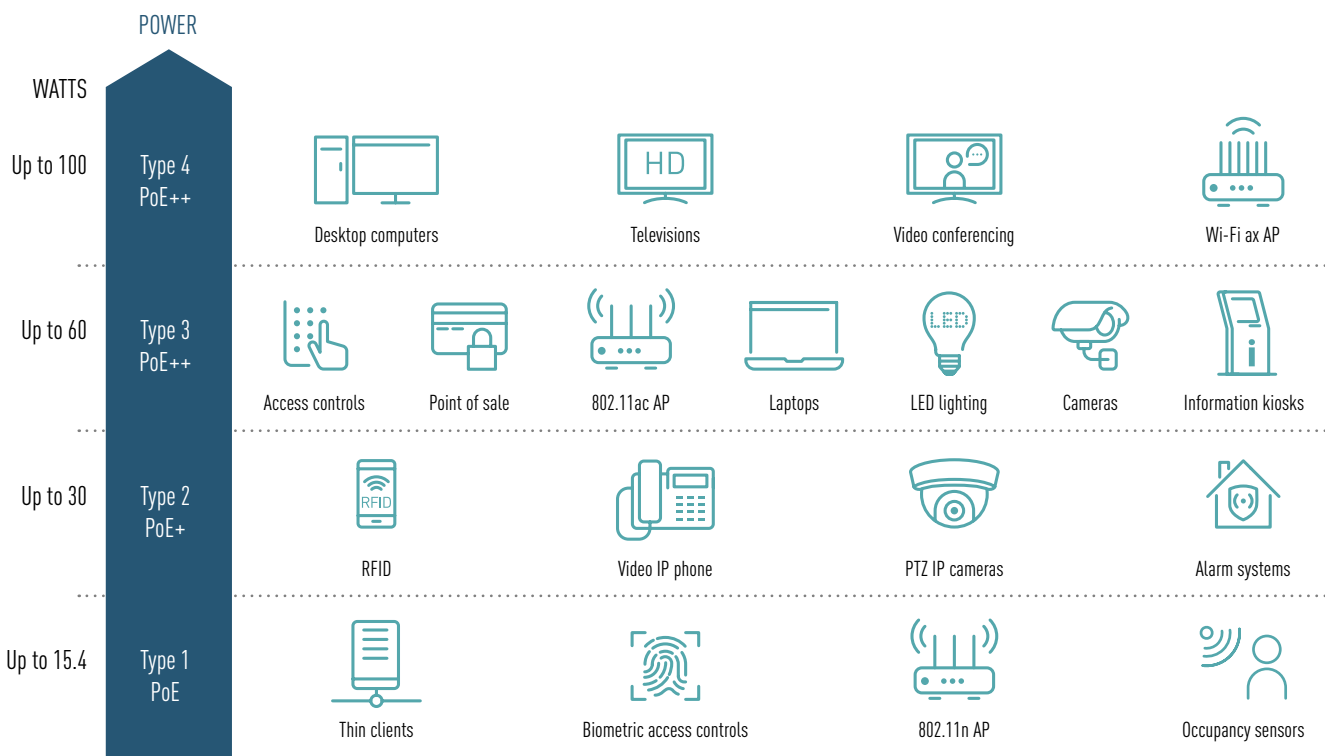

## Architecture

### BUILDING SYSTEMS ARE MOVING TO A SINGLE IP NETWORK

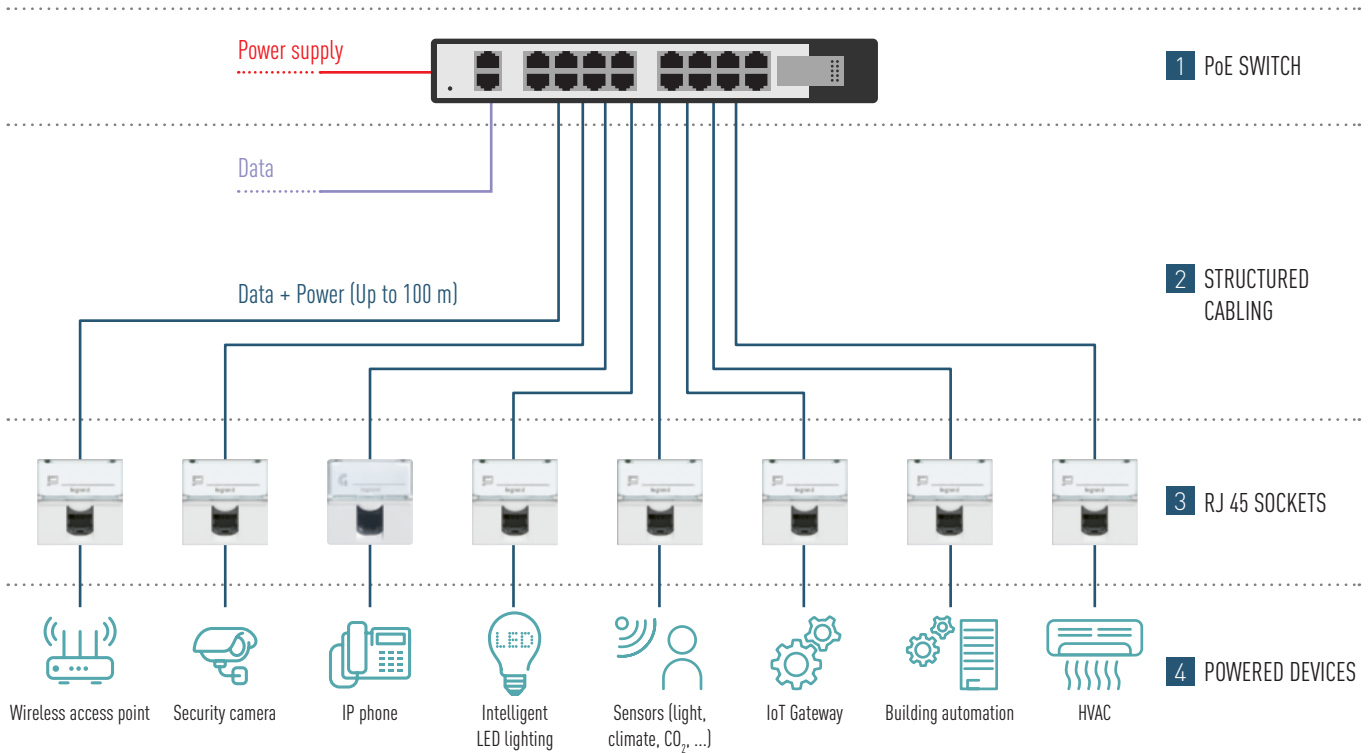

#### 1 PoE SWITCH

A Power over Ethernet switch is a device which supplies power and data on Ethernet cabling. It draws power from its own conventional power source and provides power to the rest of the PoE system.



#### 2 STRUCTURED CABLING

The twisted pairs cable is the power and data transmission medium of a PoE system. It is used to provide the link between two devices enabling bi-directional communication and uni-directional supply of power.



**Shielded Category 6A cabling is recommended for optimum future-proofing and is the best choice for the Internet of Things and is recommended by current design standards for BIoT.**

#### 3 RJ 45 SOCKETS

Universal RJ 45 socket to connect devices.



#### 4 POWERED DEVICES

A powered device is a device which receives power from the power sourcing equipment. It does not require its own conventional power source.



## Compliance of the cabling to PoE

The international installation standard ISO/IEC 14763-2 imposes consideration of PoE for any new installation.

It defines three Categories:

| Category | $I_c$ - average          | $i_c$         | Controls required during...             |   |
|----------|--------------------------|---------------|---|---|
|          |                          |               | attachment of remote powering equipment | planning of subsequent cabling installation |
| RP1      | $\leq 212$ mA            | $\leq 500$ mA | Yes                                     | Yes   |
| RP2      | $> 212$ mA<br>$< 500$ mA | $\leq 500$ mA | Yes                                     | Yes   |
| RP3      | -                        | $\leq 500$ mA | No                                      | Yes   |

The infrastructure must be of type RP3 to comply to residential, commercial and industrial environments.

“For installation of cabling in accordance with ISO/IEC 11801-2, ISO/IEC 11801-3, ISO/IEC 11801-4 and ISO/IEC 11801-6, the planning, installation and administration requirements of Category RP3 shall be applied.”

This means that it allows the maximum PoE (Type 4 90w) on 100% of the links without overheating and without disrupting the Ethernet signal.

In order to achieve the RP3 category, multiple heat calculations must be made considering the environment temperature, types of cables, type of cable management, the number of cables per bundles, shape of the bundles and separation of the bundles. This is then used to calculate the maximum achievable distance of the channels at the estimated cable temperature.

Legrand has made the PoE guide for simplified installation conditions by making some assumptions. Following this guide provides guaranteed distances and compliance to RP3 Category.

As a reminder, all PoE assumption and calculations must be documented and kept in the technical specifications for reference in future additions to the cabling.

**WANT TO KNOW MORE ABOUT  
PoE AND INCREASE THE  
POWER OF YOUR NETWORK?**



► **CONTACT YOUR LOCAL SALES  
REP TO GET OUR PoE GUIDE!**

# Structured cabling: the Legrand 25-year application warranty

Almost all manufacturers now offer their warranty on the structured cabling systems. Because these warranties can have significant difference, and with promises ranging from 15 years to 25 years or even “lifetime”, it can be complicated for the end user to understand the concept.

## What the warranty really means

The duration of the warranty is actually the least important part of the contract. Anyone can assume that a warranty above 15 years simply means that the manufacturer trusts his product. In fact, products are only a part of the warranty, but not the main aspect. It's actually about creating a trust relationship between the end user and the manufacturer. It's about the manufacturer making the following statement: “If you choose my products, I will ensure that everything functions properly so that you don't have to worry about any risks.” Now let's look at what needs to be covered.

“IF YOU CHOOSE MY PRODUCTS, I WILL ENSURE THAT EVERYTHING FUNCTIONS PROPERLY SO THAT YOU DON'T HAVE TO WORRY ABOUT ANY RISKS.”

## Actors

Since the objective is for the end user to obtain support from the manufacturer, he must be the beneficiary of the contract. The installation company can and must be stated in the contract but can be neither the benefactor nor the beneficiary. In either of those two cases, the end user would lose the relationship with the manufacturer.



## Questions to ask about the manufacturer

How long has the manufacturer been in existence? Will that company still exist in 25 years to honor the warranty? Does the company have local legal representation in the country to support this warranty? And do they have the sufficient financial strength in case of warranty claim?

The end user should therefore first verify the capacity of the manufacturer to honor that warranty based on the size of company, historical background, and reputation.

## What about the labor?

The best of products cannot guarantee any performance unless the installation is done in the proper way. For this reason, manufacturers have created a training and certification program for installers.

It generally includes hands-on product practices, but most important, it covers the standards and rules of installation. This ensures the manufacturer that his products will be installed according to best practices and therefore offer the optimal performance. And by having the tight relationship with the installer, the manufacturer is aware of the progress of the installation and may make site visits and on-site support.



## THE COMMON PERFORMANCE WARRANTY THEREFORE LEAVES SIGNIFICANT RESPONSIBILITY ON THE END USER

Generally, each person having passed the training receives a certificate of success, and the company obtains a “Certified Installer” certificate. It is not uncommon for end users to verify these documents during the tender process. In this sense, by requesting a warranty, the end user is actually ensuring the right technical support as well as project control from the manufacturer.

### Local support

Local support is a critical aspect of a warranty program. In case of technical problem, how long will it take the manufacturer to visit the site? What legal rights does the end user have when he received a warranty from an overseas supplier without a local office. In most countries, the company legally responsible is the importer, which might be the distributor and not the manufacturer. The end user should always consider how he will be able to communicate with the manufacturer, how he'll obtain the right support, and what means he may have to protect his interests in case of disagreement.

### The application warranty

The most common warranty is the Performance Warranty. In this version, the manufacturer ensures that the installer is properly trained, and request him to sign a contract where he confirms that he has followed the proper methods.

A very simplistic explanation of this warranty is the following:

- The products are all compliant
- The installation is compliant
- The performance of the links is compliant (Class EA for example)

At first glance this may seem sufficient, but although this does confirm the confidence of the manufacturer in his products and in the installation from the installer, it may not actually correspond to the expectations of the customer. Here are some details not covered:

- In fiber, the links are only required to meet standard values, which may not actually allow the applications expected. For example, multimode OM4 links of 3 connectors with Insertion Loss 2.25dB are perfectly compliant to standards, but none of the recent applications will function due to a budget limited to around 1.8dB.
- In copper, a Channel is defined for 100m maximum. But this is only at 20°C. As temperature increases, due to environment or to PoE, performance degrades. If the link no longer functions because the temperature increased, the manufacturer does not consider this a defect and will remind the customer that he's responsible for respecting standards during operations. The customer would therefore be expected to either maintain the temperature at 20°C, or to have designed with shorter links to compensate for temperature.

The common Performance Warranty therefore leaves significant responsibility on the end user. For this reason, Legrand has innovated with a 25-year Application Warranty. It's intended to ensure the customer that not only everything is compliant, but also that all applications will function on the system.

WARRANTY  
25  
YEARS  
PERFORMANCE



# Structured cabling: the Legrand 25-year application warranty

Here are the key features:

## ► FIBER

Legrand supervises the design and architecture to ensure that all the fiber links have adequate lengths to support the applications. Then the standard test limit used for testing are replaced with far stricter limits not only reflecting the superior performance of Legrand products, but also assuring all the requested applications.

A list of applications is made available to the customer.

## ► COPPER

The temperature has never been such an issue until the appearance of PoE. Sending power in a cable always creates heat, which in the case of PoE, could increase the temperature of more than 30°C. The installation standards provide all necessary information to ensure that the applications still function under PoE. But in some cases, the customer may need to assess the existing power through the cables for every new connection of a device. This can be extremely complex to implement in the operations processes. Below is a table of the Remote Powering Categories as defined in the International installation standard ISO/IEC 14763-2:

| Category | $I_c$ - average          | $i_c$         | Controls required during...             |   |
|----------|--------------------------|---------------|---|---|
|          |                          |               | attachment of remote powering equipment | planning of subsequent cabling installation |
| RP1      | $\leq 212$ mA            | $\leq 500$ mA | Yes                                     | Yes   |
| RP2      | $> 212$ mA<br>$< 500$ mA | $\leq 500$ mA | Yes                                     | Yes   |
| RP3      | -                        | $\leq 500$ mA | No                                      | Yes   |

Compliance to the ISO/IEC 11801 series requires an installation compliant to ISO/IEC 14763-3, which mandates compliance to Category RP3.

This allows the maximum PoE (Type 4 90w) on 100% of the links without overheating and without disrupting the Ethernet signal, but most of all, without the need to control during connection of devices.

In order to achieve the RP3 category, multiple heat calculations must be made considering the environment temperature, types of cables, type of cable management, the number of cables per bundles, shape of the bundles and separation of the bundles. This is then used to calculate the maximum achievable distance of the channels at the estimated cable temperature.



THE CUSTOMER MAY NEED  
TO ASSESS THE EXISTING  
POWER THROUGH THE  
CABLES FOR EVERY NEW  
CONNECTION OF A DEVICE

This can be quite a challenging work, so Legrand has made a guide for simplified installation conditions by making some assumptions. Following this guide provides guaranteed distances and compliance to RP3 Category.

As part of the Application Warranty, Legrand provides the customer with the initial installation conditions so that the installer can provide a compliant installation. This information is recorded as part of the warranty, and all measurements are verified to comply to stated lengths. This means that Legrand is guaranteeing all applications, including PoE on the structured cabling, as part of the 25-year Application Warranty.

Legrand is therefore able to remove this responsibility from the customer and include it in the warranty.

The customer can then be confident that all stated applications function on the copper cabling, including PoE, if the environment remains within the assumptions stated.



LEGRAND IS GUARANTEEING ALL APPLICATIONS, INCLUDING PoE ON THE STRUCTURED CABLING, AS PART OF THE 25-YEAR APPLICATION WARRANTY

### Conclusion

Warranties are not all alike. The customer should check the details such as the local presence and reliability of the manufacturer, and most important, the warranty coverage.

**The Legrand 25-year Application Warranty goes far beyond the traditional Performance Warranties and offers what's really important to the customer: peace of mind.**



THE LEGRAND 25-YEAR APPLICATION WARRANTY GOES FAR BEYOND THE TRADITIONAL PERFORMANCE WARRANTIES AND OFFERS WHAT'S REALLY IMPORTANT TO THE CUSTOMER: PEACE OF MIND

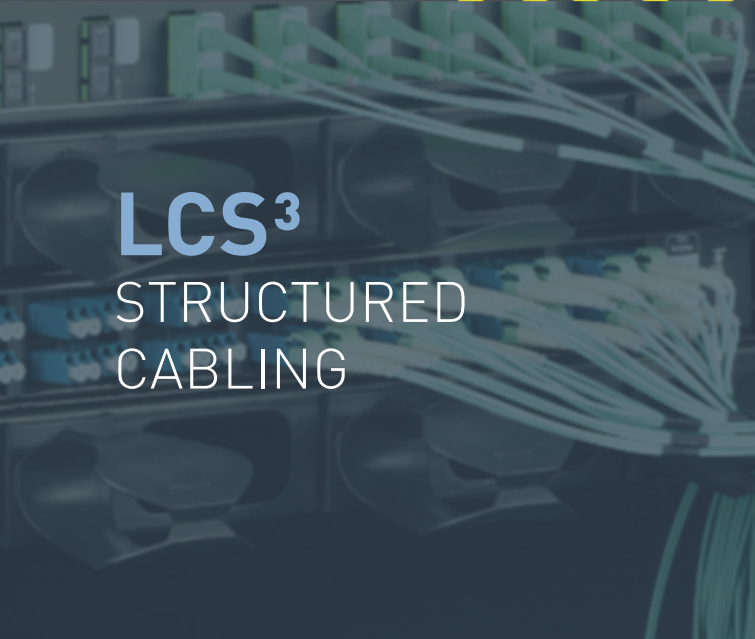
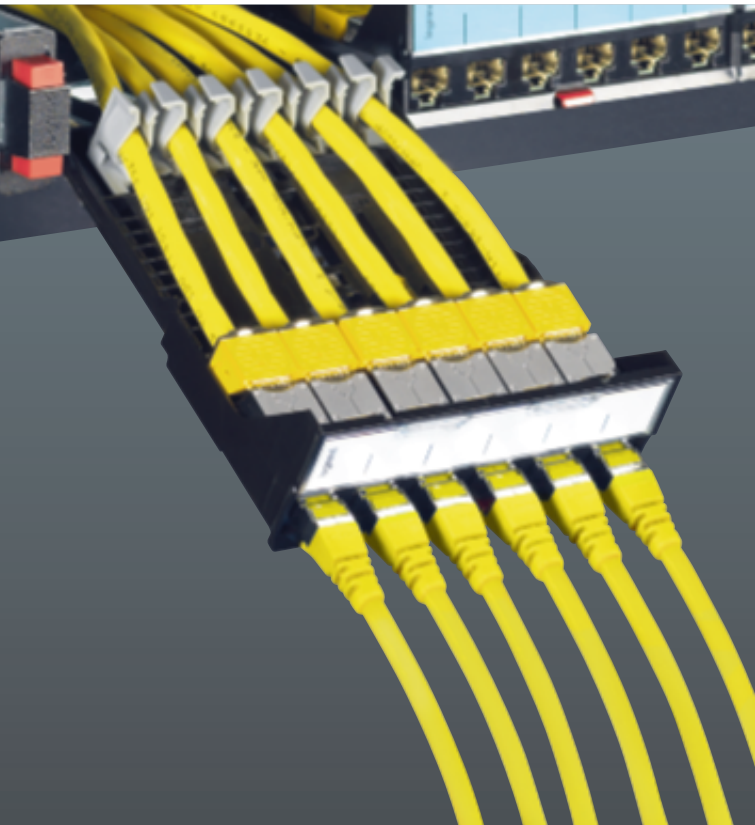

# LCS<sup>3</sup> STRUCTURED CABLING

## Selection charts

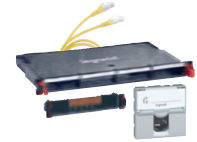

**P. 94**  
LCS<sup>3</sup>  
connectivity solutions

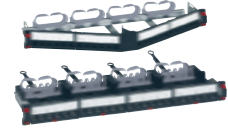

**P. 114**  
Cat. 8  
LCS<sup>3</sup> patch panels

## LCS<sup>3</sup> Copper

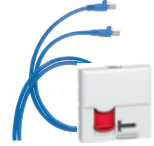

**P. 123**  
Cat. 6  
LCS<sup>3</sup> cables,  
cords and RJ 45  
sockets

## LCS<sup>3</sup> Fiber optic



**P. 135**  
LCS<sup>3</sup> cables and  
preterminated links



**P. 141**  
LCS<sup>3</sup> pigtails, case  
and quick-connect  
connectors

## Audio/video system



**P. 144**  
Multiparticipant  
HDMI projection  
and MediaHub

## LCS<sup>3</sup> Enclosures



**P. 149**  
Server cabinets



**P. 152**  
Wall-mounting  
cabinets and  
accessories

## LCS<sup>3</sup> Energy distribution

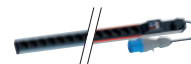

**P. 154**  
Zero-U Basic PDUs

## NEW PRODUCTS

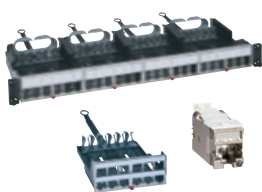

**LCS<sup>3</sup> copper system**  
LCS<sup>3</sup> Series HDJ flat  
panels, cassettes and RJ  
45 HD Jack connectors  
**(p. 132)**



**LCS<sup>3</sup> copper system**  
PoE Ethernet tablet  
switches, 5 ports :  
- with EU power supply cord  
- with BS power supply cord  
**(p. 133)**



**P. 112**  
LCS³ enclosures



**P. 113**  
LCS³ Power  
Distribution Units



**P. 115**  
Cat. 8  
LCS³ connector,  
cables and cords



**P. 116**  
Cat. 6A  
LCS³ patch panels  
and connectors



**P. 118**  
Cat. 6A  
LCS³ cables, cords  
and RJ 45 sockets



**P. 121**  
Cat. 6  
LCS³ patch panels  
and connectors



**P. 127**  
Cat. 5e  
LCS³ patch  
panels and  
connectors



**P. 129**  
Cat. 5e  
LCS³ cables,  
cords and  
RJ 45 sockets



**P. 132**  
LCS³ Series HDJ:  
panels, cassettes  
and connectors



**P. 133**  
PoE WAP/switches,  
doublers, adaptors  
and accessories



**P. 137**  
LCS³ 19" fiber  
optic drawers  
and blocks

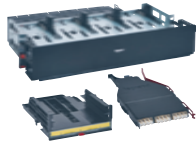

**P. 138**  
LCS³ High  
Density panels,  
slim cassettes,  
cassettes and  
patching kits



**P. 139**  
LCS³ Meet-Me  
Room solutions



**P. 140**  
LCS³ UHD drawers  
and cassettes



**P. 142**  
LCS³  
patch cords and  
feedthrough sockets



**P. 145**  
HDMI and  
HD15 sockets,  
HDMI extender



**P. 146**  
Jack, RCA and XLR  
sockets, loudspeaker  
sockets



**P. 147**  
Cords and  
adaptors



**P. 148**  
USB Type-C adaptors  
and cords, data cords,  
data sockets and  
Type-A extender



**P. 149**  
Cabling cabinets

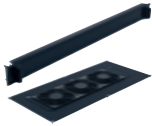

**P. 150**  
Accessories for  
server cabinets and  
cabling cabinets

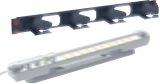

**P. 153**  
19" accessories



**P. 153**  
Cabling openrack  
and accessories



**P. 155**  
1U/2U horizontal  
Basic PDUs



**P. 156**  
1U Basic PDUs



**P. 157**  
PDUs to be  
equipped and  
accessories



**LCS³ fiber optic**  
Meet-Me Room solutions:  
cassettes, frames and  
accessories  
**(p. 139)**

# Legrand cabling system, LCS<sup>3</sup> copper selection chart



## patch panels and connectors

|  |  |                     | Cat. 8   | Cat. 6A  | Cat. 6   | Cat. 5e  |
|--|--|---------------------|----------|----------|----------|----------|
| <b>LCS<sup>3</sup> 1U 19" FLAT PATCH PANELS</b>                      |  |                     |          |          |          |          |
|  | 1U patch panels equipped with 24 connectors              | STP                 | 0 337 82 | 0 337 72 | 0 337 62 | -        |
|  |  | UTP                 | -        | 0 337 70 | 0 337 60 | 0 337 50 |
|  |  | FTP                 | -        | -        | 0 337 61 | 0 337 51 |
|  | 1U patch panels to be equipped                           | With cassette       | 0 337 90 | 0 337 90 | 0 337 90 | 0 337 90 |
|  |  | Without cassette    | 0 337 91 | 0 337 91 | 0 337 91 | 0 337 91 |
|  | 1U High Density patch panel to be equipped with 48 ports |                     | -        | 0 337 93 | 0 337 93 | 0 337 93 |
| <b>LCS<sup>3</sup> 1U 10" FLAT PATCH PANELS</b>                      |  |                     |          |          |          |          |
|  | 1U 10" patch panels to be equipped                       | Up to 6 connectors  | 0 337 98 | 0 337 98 | 0 337 98 | 0 337 98 |
|  |  | Up to 12 connectors | 0 337 99 | 0 337 99 | 0 337 99 | 0 337 99 |
| <b>LCS<sup>3</sup> 1U 19" ANGLED PATCH PANELS</b>                    |  |                     |          |          |          |          |
|  | 1U angled patch panel to be equipped                     |                     | 0 337 92 | 0 337 92 | 0 337 92 | 0 337 92 |
|  | 1U High Density angled patch panel to be equipped        |                     | -        | 0 337 94 | 0 337 94 | 0 337 94 |
| <b>LCS<sup>3</sup> RJ 45 CONNECTORS AND CASSETTES TO BE EQUIPPED</b> |  |                     |          |          |          |          |
|  | 6 RJ 45 connectors for flat and angled panel             | STP                 | 0 337 85 | 0 337 75 | 0 337 65 | -        |
|  |  | UTP                 | -        | 0 337 73 | 0 337 63 | 0 337 53 |
|  |  | FTP                 | -        | -        | 0 337 64 | 0 337 54 |
|  | Cassette for flat panels to be equipped                  |                     | 0 337 55 | 0 337 55 | 0 337 55 | 0 337 55 |
|  | Cassette with shutters for flat panels to be equipped    |                     | 0 337 66 | 0 337 66 | 0 337 66 | 0 337 66 |
|  | High Density cassette for flat panels to be equipped     |                     | -        | 0 337 95 | 0 337 95 | 0 337 95 |
| <b>ACCESSORIES</b>   |  |                     |          |          |          |          |
|  | Cord guide   |                     |          | 0 337 59 |          |          |
|  | Blanking cassette  |                     |          | 0 337 57 |          |          |
|  | Port blanking modules                                    |                     |          | 0 337 56 |          |          |
|  | Cover  |                     |          | 0 337 58 |          |          |



# Legrand cabling system, LCS<sup>3</sup> copper selection chart

telephone patch panels, PoE switches and Wi-Fi Access Point

| LCS <sup>3</sup> 1U 19" TELEPHONE PATCH PANEL                                     |   |  |          |
|---|---|--|----------|
|  | 1 U telephone patch panel<br>50 ports 110 connect | 0 335 79   |          |
| PoE SWITCHES  |   |  |          |
|  | Tablet PoE Gigabit switches - non manageable      | 6 ports (4 PoE+ RJ 45 outputs) -<br>EU power supply cord         | 0 334 93 |
|   |   | 5 RJ 45 ports (4 PoE+ RJ 45 outputs) -<br>EU power supply cord   | 4 131 11 |
|   | 19" PoE Gigabit switches - manageable             | 5 RJ 45 ports (4 PoE+ RJ 45 outputs) -<br>BS power supply cord   | 4 131 13 |
|   |   | 10 RJ 45 ports (8 PoE+ RJ 45 outputs) -<br>EU power supply cord  | 0 334 90 |
|   |   | 26 RJ 45 ports (24 PoE+ RJ 45 outputs) - EU<br>power supply cord | 0 334 92 |
| PoE WI-FI ACCESS POINT  |   |  |          |
|  | PoE Wi-Fi Access Point                            | 0 335 23   |          |

# Legrand cabling system, LCS<sup>3</sup> copper selection chart

## RJ 45 patch cords and user cords

| RJ 45 PATCH CORDS AND USER CORDS |       |                 |       |                 | LCS <sup>3</sup>                                      |   |   |   |   |
|----------------------------------|-------|-----------------|-------|-----------------|---|---|---|---|---|
|                                  |       |                 |       |                 | Cat. 8  | Cat. 6A   | Cat. 6  | Cat. 5e   |   |
|                                  | S/FTP | 100 Ω impedance | 0.5 m | -               | ● 0 515 50 <sup>(1)</sup>                             | -   | -   |   |   |
|                                  |       |                 | 1 m   | -               | ● 0 518 70<br>● 0 518 66<br>● 0 515 51 <sup>(1)</sup> | -   | -   |   |   |
|                                  |       |                 |       | 2 m             | ● 0 337 03  | ● 0 518 71<br>● 0 518 67<br>● 0 515 52 <sup>(1)</sup>               | -   | -   |   |
|                                  |       |                 |       |                 | 3 m   | ● 0 337 04  | ● 0 518 72<br>● 0 518 68<br>● 0 515 53 <sup>(1)</sup>               | -   | -   |
|                                  |       |                 | 5 m   | -               |   | ● 0 518 73<br>● 0 518 69<br>● 0 515 54 <sup>(1)</sup>               | -   | -   |   |
|                                  |       |                 | F/UTP | 100 Ω impedance | 0.5 m   | -   | -   | ● 0 515 40 <sup>(1)</sup>                             | -   |
|                                  |       |                 |       |                 | 1 m   | -   | -   | ● 0 515 41 <sup>(1)</sup><br>● 0 518 54<br>● 0 518 50 | -   |
|                                  |       |                 |       |                 |   | 2 m   | -   | -   | ● 0 515 42 <sup>(1)</sup><br>● 0 518 55<br>● 0 518 51 |
|                                  |       |                 |       |                 | 3 m   |   | -   | -   | ● 0 515 43 <sup>(1)</sup><br>● 0 518 56<br>● 0 518 52 |
|                                  |       |                 |       |                 |   | 5 m   | -   | -   | ● 0 515 44 <sup>(1)</sup><br>● 0 518 57<br>● 0 518 53 |
|                                  | U/UTP | 100 Ω impedance |       |                 | 0.5 m   | -   | -   | ● 0 515 45 <sup>(1)</sup>                             | -   |
|                                  |       |                 | 1 m   | -               | -   | ● 0 515 46 <sup>(1)</sup><br>● 0 518 78<br>● 0 518 62<br>● 0 518 58 | -   |   |   |
|                                  |       |                 |       | 2 m             | -   | -   | ● 0 515 47 <sup>(1)</sup><br>● 0 518 79<br>● 0 518 63<br>● 0 518 59 | -   |   |
|                                  |       |                 | 3 m   |                 | -   | -   | ● 0 515 48 <sup>(1)</sup><br>● 0 518 80<br>● 0 518 64<br>● 0 518 60 | -   |   |
|                                  |       |                 |       | 5 m             | -   | -   | ● 0 515 49 <sup>(1)</sup><br>● 0 518 81<br>● 0 518 65<br>● 0 518 61 | -   |   |

1: High Density

# Legrand cabling system, LCS<sup>3</sup> copper selection chart











## RJ 45 patch cords and user cords, copper cables

| RJ 45 PATCH CORDS AND USER CORDS (CONTINUED) |   |         |                          |       | LCS <sup>3</sup> |                           |            |            |
|--|---|---------|--------------------------|-------|------------------|---------------------------|------------|------------|
|  |   |         |                          |       | Cat. 8           | Cat. 6A                   | Cat. 6     | Cat. 5e    |
|  | PVC   | S/FTP   | 100 Ω impedance          | 0.5 m | -                | ● 0 518 16                | -          | -          |
|  |   |         |                          | 1 m   | -                | ● 0 517 80                | -          | -          |
|  |   |         |                          | 2 m   | -                | ● 0 517 81                | -          | -          |
|  |   |         |                          | 3 m   | -                | ● 0 517 82                | -          | -          |
|  |   |         |                          | 5 m   | -                | ● 0 517 83                | -          | -          |
|  |   | SF/UTP  | 100 Ω impedance          | 1 m   | -                | -                         | ● 0 517 52 | -          |
|  |   |         |                          | 2 m   | -                | -                         | ● 0 517 53 | -          |
|  |   |         |                          | 3 m   | -                | -                         | ● 0 517 54 | -          |
|  |   |         |                          | 5 m   | -                | -                         | ● 0 517 55 | -          |
|  |   | F/UTP   | 100 Ω impedance          | 0.5 m | -                | -                         | ● 0 518 15 | ○ 0 518 14 |
|  |   |         |                          | 1 m   | -                | -                         | ● 0 517 62 | ○ 0 516 40 |
|  |   |         |                          | 2 m   | -                | -                         | ● 0 517 63 | ○ 0 516 41 |
|  |   |         |                          | 3 m   | -                | -                         | ● 0 517 64 | ○ 0 516 42 |
|  |   |         |                          | 5 m   | -                | -                         | ● 0 517 65 | ○ 0 516 43 |
|  |   | U/UTP   | 100 Ω impedance          | 0.5 m | -                | -                         | ● 0 518 18 | ○ 0 518 17 |
|  | 1 m   |         |                          | -     | ● 0 518 82       | ● 0 517 72                | ○ 0 516 36 |            |
|  | 2 m   |         |                          | -     | ● 0 518 83       | ● 0 517 73                | ○ 0 516 37 |            |
|  | 3 m   |         |                          | -     | ● 0 518 84       | ● 0 517 74                | ○ 0 516 38 |            |
|  | 5 m   |         |                          | -     | ● 0 518 85       | ● 0 517 75                | ○ 0 516 39 |            |
|  | <b>COPPER CABLES (305 M OR 500 M REELS)</b> |         |                          |       |                  |                           |            |            |
|  | LSZH  | S/FTP   | 4 pairs                  | 500 m | ● 0 337 88       | ● 0 327 77 <sup>(1)</sup> | -          | -          |
|  |   |         | 4 pairs (indoor/outdoor) | 500 m | -                | ● 0 338 90                | -          | -          |
|  |   |         | 2 x 4 pairs              | 500 m | -                | ● 0 327 79 <sup>(1)</sup> | -          | -          |
|  |   | SF/UTP  | 4 pairs                  | 500 m | -                | -                         | ● 0 327 57 | -          |
|  |   | F/UTP   | 4 pairs                  | 305 m | -                | -                         | ● 0 328 56 | ○ 0 327 52 |
|  |   |         | 4 pairs                  | 500 m | -                | ● 0 327 78                | ● 0 327 56 | ○ 0 328 50 |
|  |   |         | 2 x 4 pairs              | 500 m | -                | ● 0 328 78                | ● 0 327 76 | -          |
|  |   | F/FTP   | 4 pairs                  | 500 m | -                | ● 0 327 99                | -          | -          |
|  |   |         | 2 x 4 pairs              | 500 m | -                | ● 0 327 98                | -          | -          |
|  | U/UTP                                       | 4 pairs | 305 m                    | -     | -                | ● 0 327 54                | ○ 0 327 50 |            |
|  |   |         | 500 m                    | -     | ● 0 327 87       | ● 0 328 61                | ○ 0 328 53 |            |
|  | U/FTP                                       | 4 pairs | 500 m                    | -     | ● 0 328 84       | -                         | -          |            |
| PVC  | PVC   | SF/UTP  | 4 pairs                  | 500 m | -                | -                         | ● 0 327 59 | -          |
|  |   | F/UTP   | 4 pairs                  | 305 m | -                | -                         | ● 0 328 57 | ○ 0 327 53 |
|  |   |         | 4 pairs                  | 500 m | -                | -                         | ● 0 327 58 | -          |
|  |   | U/UTP   | 4 pairs                  | 305 m | -                | -                         | ● 0 327 55 | ○ 0 327 51 |

1: Cat. 7 cable



# Legrand cabling system, LCS<sup>3</sup> copper selection chart

RJ 45 sockets

| WHITE MOSAIC RANGE RJ 45 SOCKETS  |                              |     | Cat. 6A  | Cat. 6   | Cat. 5e  |
|---|------------------------------|-----|----------|----------|----------|
|    | 1 module                     | STP | 0 765 73 | 0 765 63 | -        |
|   |                              | UTP | 0 765 71 | 0 765 61 | 0 765 51 |
|   |                              | FTP | -        | 0 765 62 | 0 765 52 |
|    | 2 modules                    | STP | 0 765 76 | 0 765 66 | -        |
|   |                              | UTP | 0 765 74 | 0 765 64 | 0 765 54 |
|   |                              | FTP | -        | 0 765 65 | 0 765 55 |
|    | 2 x 45° tilted modules       | STP | 0 765 08 | 0 765 07 | -        |
|   |                              | UTP | 0 765 09 | 0 765 03 | 0 765 01 |
|   |                              | FTP | -        | 0 765 05 | -        |
|    | 90° socket                   | STP | -        | 0 765 93 | -        |
|   |                              | FTP | -        | 0 765 92 | -        |
|    | Antimicrobial                | STP | 0 765 84 | 0 765 83 | -        |
|   |                              | UTP | -        | 0 765 81 | -        |
|   |                              | FTP | -        | 0 765 82 | -        |
|   | Controlled access            | STP | 0 765 99 | 0 765 96 | -        |
|   |                              | UTP | 0 765 90 | 0 765 94 | 0 765 97 |
|   |                              | FTP | -        | 0 765 95 | 0 765 98 |
|  | Green flap                   | STP | 0 765 24 | -        | -        |
|   |                              | UTP | 0 765 26 | -        | -        |
|   |                              | FTP | -        | 0 765 22 | -        |
|  | Orange flap                  | STP | 0 765 25 | -        | -        |
|   |                              | UTP | 0 765 27 | -        | -        |
|   |                              | FTP | -        | 0 765 23 | -        |
|  | 2 RJ 45 sockets for trunking | FTP | -        | 0 765 46 | 0 765 42 |
|  | Copper feedthrough           | STP | 0 786 28 | -        | -        |
|   |                              | UTP | -        | 0 786 22 | 0 786 20 |
|   |                              | FTP | -        | 0 786 23 | 0 786 21 |

# Legrand cabling system, LCS<sup>3</sup> copper selection chart

## zone distribution boxes

| ZONE DISTRIBUTION BOXES / CONSOLIDATION POINT                                      |                                      |                 |                |      | Cat. 6A  | Cat. 6   | Cat. 5e  |
|--|--------------------------------------|-----------------|----------------|------|----------|----------|----------|
|   | Zone distribution box to be equipped | 12 ports        |                |      | 0 337 96 | 0 337 96 | 0 337 96 |
|  |                                      | 24 ports        |                |      | 0 337 97 | 0 337 97 | 0 337 97 |
| RJ 45 CONNECTORS FOR ZONE DISTRIBUTION BOXES                                       |                                      |                 |                |      |          |          |          |
|   | 6 RJ 45 connectors                   | STP             |                |      | 0 337 75 | 0 337 65 | -        |
|  |                                      | UTP             |                |      | 0 337 73 | 0 337 63 | 0 337 53 |
|  |                                      | FTP             |                |      | -        | 0 337 64 | 0 337 54 |
| RJ 45 CORDS FOR ZONE DISTRIBUTION BOXES  |                                      |                 |                |      |          |          |          |
|  | S/FTP cords                          | 100 Ω impedance | RJ 45/stripped | 8 m  | 0 517 86 | -        | -        |
|  |                                      |                 |                | 15 m | 0 517 87 | -        | -        |
|  |                                      |                 |                | 20 m | 0 517 88 | -        | -        |
|  |                                      |                 | RJ 45 - RJ 45  | 8 m  | 0 515 23 | -        | -        |
|  |                                      |                 |                | 15 m | 0 515 24 | -        | -        |
|  |                                      |                 |                | 20 m | 0 515 25 | -        | -        |
|  | U/UTP cords                          | 100 Ω impedance | RJ 45/stripped | 8 m  | -        | 0 517 57 | -        |
|  |                                      |                 |                | 15 m | -        | 0 517 58 | -        |
|  |                                      |                 |                | 20 m | -        | 0 517 59 | -        |
|  |                                      |                 | RJ 45 - RJ 45  | 8 m  | -        | 0 515 10 | 0 515 00 |
|  |                                      |                 |                | 15 m | -        | 0 515 11 | 0 515 01 |
|  |                                      |                 |                | 20 m | -        | 0 515 12 | 0 515 02 |
|  | F/UTP cords                          | 100 Ω impedance | RJ 45/stripped | 8 m  | -        | 0 517 96 | -        |
|  |                                      |                 |                | 15 m | -        | 0 517 97 | -        |
|  |                                      |                 |                | 20 m | -        | 0 517 98 | -        |
| RJ 45 - RJ 45  |                                      |                 | 8 m            | -    | 0 515 13 | 0 515 03 |          |
|  |                                      |                 | 15 m           | -    | 0 515 14 | 0 515 04 |          |
|  |                                      |                 | 20 m           | -    | 0 515 15 | 0 515 05 |          |

# Legrand cabling system, LCS<sup>3</sup> fiber optic selection chart

19" standard solutions

## CONFIGURE YOUR LCS<sup>3</sup> FIBER OPTIC SYSTEM

Example:

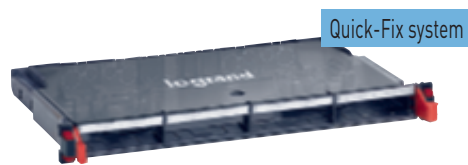

Modular drawer

+

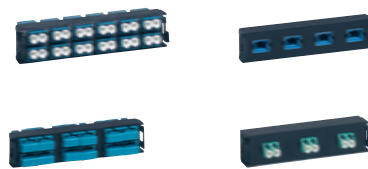

Blocks

+

## DRAWERS TO BE EQUIPPED (p. 137)

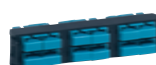
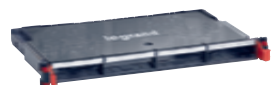

| FIBER OPTIC DRAWERS |  |          |                       | FIBER OPTIC BLOCKS |           |             |              |             |               |           |             |
|---------------------|--|----------|-----------------------|--------------------|-----------|-------------|--------------|-------------|---------------|-----------|-------------|
| Size                | Type                                   | Cat.No   | Max. number of blocks | Number of fibers   | SC duplex |             | SC duplex HD |             | SC APC duplex | LC duplex |             |
|                     |  |          |                       |                    | Multimode | Single-mode | Multimode    | Single-mode | Single-mode   | Multimode | Single-mode |
| 19" modular         | FLAT DRAWERS - QUICK-FIX SYSTEM        |          |                       |                    |           |             |              |             |               |           |             |
|                     | To be equipped with fiber optic blocks | 0 321 00 | 4                     | 6                  | 0 321 20  | 0 321 10    | -            | -           | 0 321 12      | 0 321 23  | 0 321 13    |
|                     |  |          |                       | 12                 | -         | -           | 0 321 21     | 0 321 11    | -             | 0 321 24  |             |
|                     |  |          |                       | 24                 | -         | -           | -            | -           | -             | -         | -           |
|                     | ANGLED DRAWERS - QUICK-FIX SYSTEM      |          |                       |                    |           |             |              |             |               |           |             |
|                     | To be equipped with fiber optic blocks | 0 321 01 | 4                     | 6                  | 0 321 20  | 0 321 10    | -            | -           | 0 321 12      | 0 321 23  | 0 321 13    |
| 12                  |  |          |                       | -                  | -         | 0 321 21    | 0 321 11     | -           | 0 321 24      | 0 321 14  |             |
| 24                  |  |          |                       | -                  | -         | -           | -            | -           | -             |           | -           |

## EQUIPPED DRAWERS (p. 137)

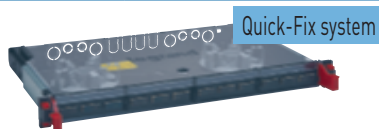

| Size         | Type             | Capacity (fibers) | SC duplex |             | SC APC duplex |
|--------------|------------------|-------------------|-----------|-------------|---------------|
|              |                  |                   | Multimode | Single-mode | Single-mode   |
| 19" modular  | SLIDING          |                   |           |             |               |
|              | Quick-Fix system | 24                | 0 321 02  | 0 321 06    | -             |
|              |                  | 48                | -         | -           | -             |
| 19"          | SLIDING          |                   |           |             |               |
|              | Screw fixing     | 24                | 0 321 61  | 0 321 64    | 0 321 66      |
|              |                  | 48                | -         | -           | -             |
|              | ROTATING         |                   |           |             |               |
| Screw fixing | 36               | 0 321 72          | 0 321 74  | -           |               |
|              | 72               | -                 | -         | -           |               |

1 : MTP is a registered trademark of US Conec Ltd

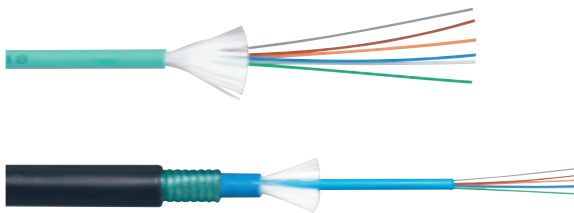

Cables

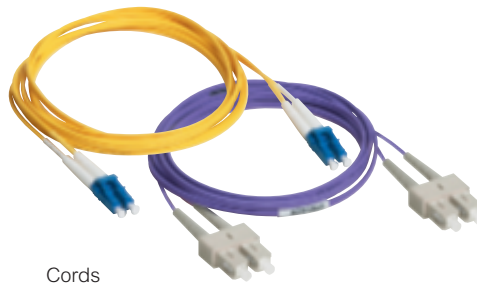

Cords



Pigtails (p. 141)



ACCESSORIES

| LC duplex HD |             | LC APC duplex | ST        |             | 4 MTP <sup>(1)</sup> feedthrough adaptor |             | Blanking plate | Copper block for 5 RJ 45 | Cassette for pigtail | Coiling kit | Accessory for fan-out |
|--------------|-------------|---------------|-----------|-------------|--|-------------|----------------|--------------------------|----------------------|-------------|-----------------------|
| Multimode    | Single-mode | Single-mode   | Multimode | Single-mode | Multimode                                | Single-mode |                |                          |                      |             |                       |
| -            | -           | -             | 0 321 27  | 0 321 17    | 0 321 34                                 | 0 321 33    | 0 321 29       | 0 321 32                 | 0 321 30             | 0 321 31    | 0 321 28              |
| -            | -           | 0 321 16      | -         | -           |  |             |                |                          |                      |             |                       |
| 0 321 25     | 0 321 15    | -             | -         | -           |  |             |                |                          |                      |             |                       |
| -            | -           | -             | 0 321 27  | 0 321 17    | 0 321 34                                 | 0 321 33    | 0 321 29       | -                        | 0 321 30             | 0 321 31    | 0 321 28              |
| -            | -           | 0 321 16      | -         | -           |  |             |                |                          |                      |             |                       |
| 0 321 25     | 0 321 15    | -             | -         | -           |  |             |                |                          |                      |             |                       |

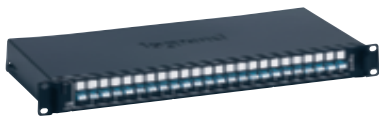

| LC duplex |             | LC APC duplex | ST        |
|-----------|-------------|---------------|-----------|
| Multimode | Single-mode | Single-mode   | Multimode |
| -         | -           | -             | -         |
| 0 321 04  | -           | -             | -         |
| -         | -           | -             | 0 321 63  |
| 0 321 62  | 0 321 65    | 0 321 67      | -         |
| -         | -           | -             | -         |
| 0 321 71  | 0 321 73    | -             | -         |

# Legrand cabling system, LCS<sup>3</sup> fiber optic selection chart

## 19" High Density solutions

### CONFIGURE YOUR LCS<sup>3</sup> HIGH DENSITY FIBER OPTIC SYSTEM

Example:



Modular panel

+

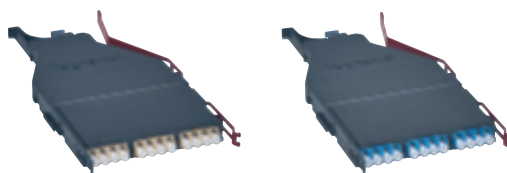

Cassettes

+

### HIGH DENSITY PANELS TO BE EQUIPPED (p. 138)

| HIGH DENSITY PANELS                |  |          |                        |                              |                                    |   |   |                   |                   |                        |                       |             |           |                   |                        |                        |   |   |
|------------------------------------|--|----------|------------------------|------------------------------|------------------------------------|---|---|-------------------|-------------------|------------------------|-----------------------|-------------|-----------|-------------------|------------------------|------------------------|---|---|
| Size                               | Type   | Cat.No   |                        |                              | Capacity for 1U                    | Cat.No  | Number of fibers                                    | SC                |                   | SC HD                  |                       | SC APC      |           | LC                |                        |                        |   |   |
|                                    |  | 1 U      | 2 U                    | 4 U                          |                                    |   |   | Multimode         | Single-mode       | Multimode              | Single-mode           | Single-mode | Multimode |                   |                        |                        |   |   |
| High Density 19" modular           | To be equipped with cassettes to be equipped with fiber optic blocks                   | 0 321 75 | 0 321 76               | 0 321 77                     | CASSETTES TO BE EQUIPPED           |   | FIBER OPTIC BLOCKS                                  |                   |                   |                        |                       |             |           |                   |                        |                        |   |   |
|                                    |  |          |                        |                              | 4                                  | 0 321 41  | 6   | 0 321 20 (duplex) | 0 321 10 (duplex) | -                      | -                     | 0 321 12    | -         | -                 | 0 321 23 (duplex)      | 0 321 36 (duplex-aqua) | - | - |
|                                    |  |          |                        |                              |                                    |   | 12  | -                 | -                 | 0 321 21 (duplex)      | 0 321 11 (duplex)     | -           | -         | 0 321 24 (duplex) | 0 321 37 (duplex-aqua) | -                      | - |   |
|                                    | 24   | -        | -                      | -                            |                                    |   | -   | -                 | -                 | -                      | -                     | -           | -         |                   |                        |                        |   |   |
|                                    | To be equipped with pre-equipped cassettes (supplied with set of 6 or 12 OM3 pigtails) | 0 321 75 | 0 321 76               | 0 321 77                     | PRE-EQUIPPED CASSETTES             |   | PRETERMINATED (A/C POLARITY)                        |                   |                   |                        |                       |             |           |                   |                        |                        |   |   |
|                                    |  |          |                        |                              | 4                                  | -   | 12  | -                 | -                 | 0 321 43 (OM4)         | 0 321 45 (OS2)        | -           | -         | 0 321 48 (OM4)    | -                      | -                      |   |   |
|                                    |  |          |                        |                              |                                    |   | 24  | -                 | -                 | 0 321 59 (OM4)         | 0 321 60 (OS2)        | -           | -         | -                 | -                      |                        |   |   |
|                                    |  |          |                        |                              | WITH FIBER OPTIC BLOCKS + PIGTAILS |   | 6   | -                 | -                 | 0 321 80 (duplex-OM3); | 0 321 84 (duplex-OM3) | -           | -         | -                 | -                      |                        |   |   |
|                                    | 12   | -        | -                      | 0 321 82 (duplex-OM3);       | 0 321 86 (duplex-OM3)              | -   | -   | -                 | -                 |                        |                       |             |           |                   |                        |                        |   |   |
|                                    | To be equipped with slim cassettes   | 0 321 75 | 0 321 76               | 0 321 77                     | SUPPORT FOR SLIM CASSETTES         |   | PRETERMINATED - SLIM CASSETTES (UNIVERSAL POLARITY) |                   |                   |                        |                       |             |           |                   |                        |                        |   |   |
| 4                                  |  |          |                        |                              | 0 321 38                           | 12  | -   | -                 | -                 | -                      | -                     | -           | -         | -                 |                        |                        |   |   |
| Zero-U kit                         | To be equipped with slim cassettes   | 0 321 03 |                        | SUPPORT FOR SLIM CASSETTES   |                                    | PRETERMINATED - SLIM CASSETTES (UNIVERSAL POLARITY) |   |                   |                   |                        |                       |             |           |                   |                        |                        |   |   |
|                                    |  |          |                        | 1                            | 0 321 38                           | 12  | -   | -                 | -                 | -                      | -                     | -           | -         |                   |                        |                        |   |   |
|                                    | PRE-EQUIPPED CASSETTES   |          |                        | PRETERMINATED (A/C POLARITY) |                                    |   |   |                   |                   |                        |                       |             |           |                   |                        |                        |   |   |
|                                    | 1  |          |                        | -                            | 12                                 | -   | -   | -                 | -                 | -                      | -                     | -           | -         | -                 |                        |                        |   |   |
|                                    |  |          |                        |                              | 24                                 | -   | -   | -                 | -                 | -                      | -                     | -           | -         | -                 |                        |                        |   |   |
| WITH FIBER OPTIC BLOCKS + PIGTAILS |  | 6        | -                      | -                            | 0 321 80 (duplex-OM3);             | 0 321 84 (duplex-OM3)                               | -   | -                 | -                 | -                      |                       |             |           |                   |                        |                        |   |   |
| 12                                 | -  | -        | 0 321 82 (duplex-OM3); | 0 321 86 (duplex-OM3)        | -                                  | -   | -   | -                 |                   |                        |                       |             |           |                   |                        |                        |   |   |

1 : MTP is a registered trademark of US Conec Ltd





Links (p. 136)



Cords



Pigtails (p. 141)

|                   |                                  |                       |             |           |             |           |  |          |   | ACCESSORIES   |   |   |
|-------------------|----------------------------------|-----------------------|-------------|-----------|-------------|-----------|--|----------|---|---|---|---|
|                   |                                  | LC HD                 |             | LC APC    | ST          |           | 8 MTP <sup>(1)</sup> feedthrough adaptor |          | Blanking cassette                                   | RJ 45 copper cassette to be equipped                              | Cable management accessory  | Front management HD modular panel                                 |
| Single-mode       | Multimode                        | Single-mode           | Single-mode | Multimode | Single-mode | Multimode | Single-mode                              |          |   |   |   |   |
| 0 321 13          | -                                | -                     | -           | -         | 0 321 27    | 0 321 17  | 0 321 18                                 | 0 321 19 | 0 337 57  | 0 337 55<br>(to be equipped with copper connectors)               | 0 321 46<br>(for 1 U panel only, supplied for 2 U and 4 U panels) | 0 321 78<br>(for 1 U panel only, supplied for 2 U and 4 U panels) |
| 0 321 14 (duplex) | -                                | -                     | 0 321 16    | -         | -           |           |  |          |   |   |   |   |
| -                 | 0 321 25 (duplex)                | 0 321 15 (duplex)     | -           | -         | -           |           |  |          |   |   |   |   |
| 0 321 49 (OS2)    | -                                | -                     | -           | -         | -           | -         | -  | -        | 0 337 57  | 0 337 55<br>(to be equipped with copper connectors)               | 0 321 46<br>(for 1 U panel only, supplied for 2 U and 4 U panels) | 0 321 78<br>(for 1 U panel only, supplied for 2 U and 4 U panels) |
| -                 | 0 321 42 (OM4)                   | 0 321 44 (OS2)        | -           | -         | -           |           |  |          |   |   |   |   |
| -                 | 0 321 81 (duplex-OM3)            | 0 321 85 (duplex-OM3) | -           | -         | -           |           |  |          |   |   |   |   |
| -                 | 0 321 83 (duplex-OM3)            | 0 321 87 (duplex-OM3) | -           | -         | -           |           |  |          |   |   |   |   |
| -                 | 0 321 69 (OM4)<br>0 321 68 (OM3) | 0 321 70 (OS2)        | -           | -         | -           | -         | -  | 0 321 39 | 0 337 55<br>(to be equipped with copper connectors) | 0 321 46<br>(for 1 U panel only, supplied for 2 U and 4 U panels) | 0 321 78<br>(for 1 U panel only, supplied for 2 U and 4 U panels) |   |
| -                 | 0 321 69 (OM4)<br>0 321 68 (OM3) | 0 321 70 (OS2)        | -           | -         | -           | -         | -  | 0 321 39 | -   | -   | -   |   |
| -                 | 0 321 48 (OM4)                   | 0 321 49 (OS2)        | -           | -         | -           | -         | -  | -        | -   | 0 337 55<br>(to be equipped with copper connectors)               | -   | -   |
| -                 | 0 321 42 (OM4)                   | 0 321 44 (OS2)        | -           | -         | -           |           |  |          |   |   |   |   |
| -                 | 0 321 81 (duplex-OM3)            | 0 321 85 (duplex-OM3) | -           | -         | -           |           |  |          |   |   |   |   |
| -                 | 0 321 83 (duplex-OM3)            | 0 321 87 (duplex-OM3) | -           | -         | -           |           |  |          |   |   |   |   |

# Legrand cabling system, LCS<sup>3</sup> fiber optic selection chart

## 19" Ultra High Density solutions

**CONFIGURE YOUR LCS<sup>3</sup> ULTRA HIGH DENSITY FIBER OPTIC SYSTEM**

Example:

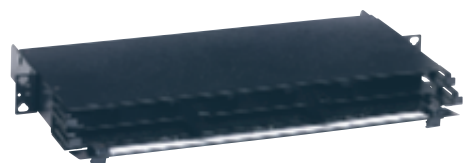

Modular drawer

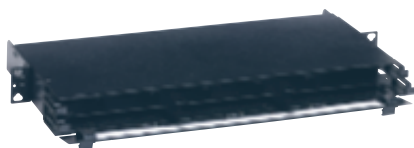

Cassettes

**ULTRA HIGH DENSITY DRAWERS TO BE EQUIPPED (p. 140)**

Ultra High Density drawers

Ultra High Density cassettes

| Size                           | Type  | Height | Number of cassettes per U | Cat.No   | Number of fibers (links) | Multimode OM4 |  |  |
|--------------------------------|---|--------|---------------------------|----------|--------------------------|---------------|--|--|
| Ultra High Density 19" modular | Cord management from the front and the back |        |                           |          |                          |               |  |  |
|                                | To be equipped with 8-fiber cassettes       | 1 U    | 18                        | 0 321 90 | 8                        | 0 321 93      |  |  |
|                                |   | 2 U    |                           | 0 321 91 |                          |               |  |  |
|                                |   | 4 U    |                           | 0 321 92 |                          |               |  |  |
|                                | To be equipped with 12-fiber cassettes      | 1 U    | 12                        | 0 321 50 | 12                       | 0 321 54      |  |  |
|                                |   | 2 U    |                           | 0 321 52 |                          |               |  |  |
|                                |   | 4 U    |                           | 0 321 53 |                          |               |  |  |
|                                | Cord management from the front              |        |                           |          |                          |               |  |  |
|                                | To be equipped with 12-fiber cassettes      | 1 U    | 12                        | 0 321 51 | 12                       | 0 321 54      |  |  |

1 : MTP is a registered trademark of US Conec Ltd



Links (p. 136)

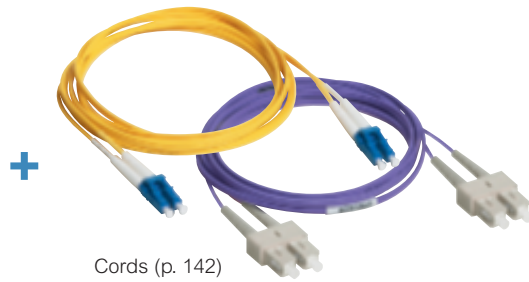

Cords (p. 142)



Adaptors

| Single-mode OS2 | LC        |             | 4 MPO (MTP <sup>(1)</sup> ) compatible |           |             |  |
|-----------------|-----------|-------------|--|-----------|-------------|--|
|                 | Multimode | Single-mode | APC single-mode                        | Multimode | Single-mode |  |
| 0 321 94        | 0 321 97  | 0 321 98    | 0 321 99                               | 0 321 95  | 0 321 96    |  |
| 0 321 55        | 0 321 58  | -           | -                                      | 0 321 56  | 0 321 57    |  |
| 0 321 55        | 0 321 58  | -           | -                                      | 0 321 56  | 0 321 57    |  |

# Legrand cabling system, LCS<sup>3</sup> fiber optic selection chart

pigtails, cables and patch cords

| PIGTAILS (p. 141) |                |          |          |  |          |                 |  |          |
|-------------------|----------------|----------|----------|--|----------|-----------------|--|----------|
| Length (m)        | OS2 - 9/125 μm |          |          |  |          | OM3 - 50/125 μm |  |          |
|                   | SC - APC       | LC - APC | SC - UPC | LC - UPC                                     | ST - UPC | SC              | LC   | ST       |
| 1                 | 0 322 40       | 0 322 42 | 0 322 41 | 0 322 43<br>0 326 24<br>(set of 12 pigtails) | 0 322 44 | 0 322 20        | 0 322 21<br>0 326 26<br>(set of 12 pigtails) | 0 322 22 |
| 2                 | 0 322 45       | 0 322 48 | 0 322 46 | 0 322 47                                     | 0 322 49 | 0 322 23        | 0 322 24                                     | -        |

| CABLES (p. 135)   |                  |          |          |          |                                  |
|---|------------------|----------|----------|----------|----------------------------------|
| Drum 2000m except information                                       | OS2 - 9/125 μm   |          |          |          |                                  |
|   | Number of fibers |          |          |          |                                  |
|   | 4                | 6        | 8        | 12       | 24                               |
| <b>Tightbuffer LSZH sheath</b><br>Indoor/Outdoor                    |                  |          |          | 0 325 50 |                                  |
| <b>Loose LSZH sheath</b><br>Indoor/Outdoor                          |                  | 0 325 02 | 0 325 12 | 0 325 03 | 0 325 14 (Dca)<br>0 325 26 (Cca) |
| <b>Loose PE sheath corrugated steel</b><br>OUTDOOR CORRUGATED STEEL |                  | 0 325 23 | 0 325 13 | 0 325 24 | 0 325 15                         |

| PATCH CORDS (p. 142) |                         |              |              |                          |              |              |                      |
|----------------------|-------------------------|--------------|--------------|--------------------------|--------------|--------------|----------------------|
| Length (m)           | OS2 - 9/125 μm          |              |              |                          |              |              |                      |
|                      | Core™ fiber patch cords |              |              | Ultra™ fiber patch cords |              |              |                      |
|                      | SC/SC duplex            | SC/LC duplex | LC/LC duplex | SC/SC duplex             | SC/LC duplex | LC/LC duplex | LC/LC Uniboot duplex |
| 0.5                  | -                       | -            | 0 326 28     | -                        | -            | -            | -                    |
| 1                    | 0 326 00                | 0 326 03     | 0 326 06     | 0 325 27                 | 0 325 30     | 0 325 33     | 0 326 86             |
| 2                    | 0 326 01                | 0 326 04     | 0 326 07     | 0 325 28                 | 0 325 31     | 0 325 34     | 0 326 87             |
| 3                    | 0 326 02                | 0 326 05     | 0 326 08     | 0 325 29                 | 0 325 32     | 0 325 35     | 0 326 88             |
| 5                    | -                       | -            | 0 326 29     | -                        | -            | 0 325 36     | 0 326 89             |
| 10                   | -                       | -            | -            | -                        | -            | -            | 0 326 92             |

|                 |  |          |                                  |   |          |               |           |
|-----------------|--|----------|----------------------------------|---|----------|---------------|-----------|
|                 |  |          |                                  |   |          |               |           |
| OM4 - 50/125 µm |  |          | Heat-shrinkable sleeve           | 50/125 and 62.5/125 µm glue-on connectors |          | Fan-out units |           |
| SC              | LC   | ST       |                                  | SC  | LC       | 6 fibers      | 12 fibers |
| 0 322 30        | 0 322 31<br>0 326 71<br>(set of 12 pigtails) | 0 322 32 | 0 327 44<br>(pack of 50 sleeves) | 0 331 47                                  | 0 331 00 | 0 330 48      | 0 330 49  |
| 0 322 33        | 0 322 34                                     | -        |                                  |   |          |               |           |

| OM3 - 50/125 µm  |          |          |          |          | OM4 - 50/125 µm  |   |          |  |                             |
|------------------|----------|----------|----------|----------|------------------|---|----------|--|-----------------------------|
| Number of fibers |          |          |          |          | Number of fibers |   |          |  |                             |
| 4                | 6        | 8        | 12       | 24       | 4                | 6   | 8        | 12                                     | 24                          |
|                  | 0 325 10 |          | 0 325 11 | 0 325 52 |                  | 0 326 65<br>(drum of 500m)<br>0 326 66<br>(drum of 1000m) |          | 0 325 67<br>(drum of 1000m)            | 0 326 68<br>(drum of 1000m) |
| 0 325 37         |          | 0 325 38 | 0 325 39 | 0 325 53 | 0 325 43         |   | 0 325 44 | 0 325 45<br>(Dca)<br>0 325 49<br>(Cca) |                             |
|                  |          | 0 325 40 | 0 325 41 | 0 325 42 | 0 325 46         |   | 0 325 47 | 0 325 48                               |                             |

| OM3 - 50/125 µm         |              |              | OM4 - 50/125 µm         |              |              |                          |              |                      |
|-------------------------|--------------|--------------|-------------------------|--------------|--------------|--------------------------|--------------|----------------------|
| Core™ fiber patch cords |              |              | Core™ fiber patch cords |              |              | Ultra™ fiber patch cords |              |                      |
| SC/SC duplex            | SC/LC duplex | LC/LC duplex | SC/SC duplex            | SC/LC duplex | LC/LC duplex | SC/SC duplex             | LC/LC duplex | LC/LC Uniboot duplex |
| -                       | -            | -            | -                       | -            | -            | -                        | 0 326 33     | 0 326 95             |
| 0 326 09                | 0 326 12     | 0 326 15     | 0 322 60                | 0 322 63     | 0 322 66     | 0 326 30                 | 0 326 34     | 0 326 96             |
| 0 326 10                | 0 326 13     | 0 326 16     | 0 322 61                | 0 322 64     | 0 322 67     | 0 326 31                 | 0 326 35     | 0 326 97             |
| 0 326 11                | 0 326 14     | 0 326 17     | 0 322 62                | 0 322 65     | 0 322 68     | 0 326 32                 | 0 326 36     | 0 326 98             |
| -                       | -            | -            | -                       | -            | -            | -                        | 0 326 37     | 0 326 99             |
| -                       | -            | -            | -                       | -            | -            | -                        | -            | -                    |

Other configurations  
**On request**

Euroclasses  
**see p. 162**

# Legrand cabling system, LCS<sup>3</sup> fiber optic selection chart

simplex preterminated links and High Density preterminated links

## LCS<sup>3</sup> SIMPLEX PRETERMINATED LINKS (p. 136)



| Length (m) | Tight-buffer OM3 |               |  |
|------------|------------------|---------------|--|
|            | 6 SC - 6 SC      | 12 SC - 12 SC |  |
| 10         | 1 320 01         | 1 320 21      |  |
| 20         | 1 320 02         | 1 320 22      |  |
| 30         | 1 320 03         | 1 320 23      |  |
| 40         | 1 320 04         | 1 320 24      |  |
| 50         | 1 320 05         | 1 320 25      |  |
| 60         | 1 320 06         | 1 320 26      |  |
| 70         | 1 320 07         | 1 320 27      |  |
| 80         | 1 320 08         | 1 320 28      |  |
| 90         | 1 320 09         | 1 320 29      |  |
| 100        | 1 320 10         | 1 320 30      |  |
| 120        | 1 320 12         | 1 320 32      |  |
| 140        | 1 320 14         | 1 320 34      |  |
| 160        | 1 320 16         | 1 320 36      |  |
| 180        | 1 320 18         | 1 320 38      |  |
| 200        | 1 320 20         | 1 320 40      |  |

## LCS<sup>3</sup> HIGH DENSITY PRETERMINATED LINKS (p. 46)



| Length (m) | Fan-out - Fan-out OS2     |                             | Fan-out - Fan-out OM3     |                             |
|------------|---------------------------|-----------------------------|---------------------------|-----------------------------|
|            | 6 LC duplex - 6 LC duplex | 12 LC duplex - 12 LC duplex | 6 LC duplex - 6 LC duplex | 12 LC duplex - 12 LC duplex |
| 10         | 0 324 21                  | 0 324 31                    | 0 324 01                  | 0 324 11                    |
| 20         | 0 324 22                  | 0 324 32                    | 0 324 02                  | 0 324 12                    |
| 30         | 0 324 23                  | 0 324 33                    | 0 324 03                  | 0 324 13                    |
| 40         | 0 324 24                  | 0 324 34                    | 0 324 04                  | 0 324 14                    |
| 50         | 0 324 25                  | 0 324 35                    | 0 324 05                  | 0 324 15                    |

1 : MTP is a registered trademark of US Conec Ltd

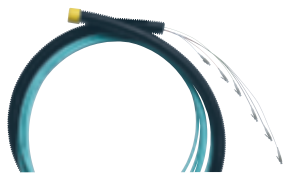

|  | 6 LC - 6 LC | 12 LC - 12 LC |
|--|-------------|---------------|
|  | 1 320 41    | 1 320 61      |
|  | 1 320 42    | 1 320 62      |
|  | 1 320 43    | 1 320 63      |
|  | 1 320 44    | 1 320 64      |
|  | 1 320 45    | 1 320 65      |
|  | 1 320 46    | 1 320 66      |
|  | 1 320 47    | 1 320 67      |
|  | 1 320 48    | 1 320 68      |
|  | 1 320 49    | 1 320 69      |
|  | 1 320 50    | 1 320 70      |
|  | 1 320 52    | 1 320 72      |
|  | 1 320 54    | 1 320 74      |
|  | 1 320 56    | 1 320 76      |
|  | 1 320 58    | 1 320 78      |
|  | 1 320 60    | 1 320 80      |

OM4 and OM5 simplex preterminated links  
**On request**



|  | MTP <sup>(1)</sup> OS2                            | MTP <sup>(1)</sup> OM3                            |
|--|---|---|
|  | MTP <sup>(1)</sup> - MTP <sup>(1)</sup> 12 fibers | MTP <sup>(1)</sup> - MTP <sup>(1)</sup> 12 fibers |
|  | 0 324 51  | 0 324 41  |
|  | 0 324 52  | 0 324 42  |
|  | 0 324 53  | 0 324 43  |
|  | 0 324 54  | 0 324 44  |
|  | 0 324 55  | 0 324 45  |

OM4 and OM5 High Density preterminated links  
**On request**

# Legrand cabling system, LCS<sup>3</sup> audio/video selection chart

## CORDS

| CORDS FOR AUDIO/VIDEO AND DATA APPLICATIONS |  |      |                                  |
|---|--|------|----------------------------------|
|   | High Speed HDMI cords with Ethernet    | 1 m  | 0 517 32/0 398 51 <sup>(1)</sup> |
|   |  | 2 m  | 0 517 33/0 398 52 <sup>(1)</sup> |
|   |  | 3 m  | 0 517 34/0 398 53 <sup>(1)</sup> |
|   |  | 5 m  | 0 517 27/0 398 54 <sup>(1)</sup> |
|   |  | 7 m  | 0 517 35/0 398 55 <sup>(1)</sup> |
|   | Standard HDMI cords with Ethernet      | 10 m | 0 517 20                         |
|   |  | 15 m | 0 517 36                         |
|   | HDMI to micro HDMI cord                | 2 m  | 0 398 56 <sup>(1)</sup>          |
|   | DisplayPort cords                      | 2 m  | 0 514 00/0 398 58 <sup>(1)</sup> |
|   | HD15 male/male cords                   | 2 m  | 0 517 29/0 398 50 <sup>(1)</sup> |
|   |  | 5 m  | 0 517 30                         |
|   |  | 10 m | 0 517 23                         |
|   |  | 15 m | 0 517 31                         |
|   | HD15 cord + Jack 3.5 mm                | 2 m  | 0 517 22                         |
|   | RCA male/male cords                    | 2 m  | 0 514 03/0 398 67 <sup>(1)</sup> |
|   |  | 5 m  | 0 514 04/0 398 68 <sup>(1)</sup> |
|   | Jack 3.5 mm male to 2 RCA male Y cords | 2 m  | 0 514 05/0 398 69 <sup>(1)</sup> |
|   |  | 5 m  | 0 514 06/0 398 70 <sup>(1)</sup> |
|   | Jack 3.5 mm male/male cords            | 2 m  | 0 514 07/0 398 71 <sup>(1)</sup> |
|   |  | 5 m  | 0 514 08/0 398 72 <sup>(1)</sup> |
|   | TOSLINK optical digital cable          | 2 m  | 0 398 73 <sup>(1)</sup>          |

1: Supplied in a plastic bag with hook



# Legrand cabling system, LCS<sup>3</sup> audio/video selection chart





## CORDS AND CABLES

| CORDS FOR AUDIO/VIDEO AND DATA APPLICATIONS (CONTINUED) |   |   |                         |                                  |
|---|---|---|-------------------------|----------------------------------|
|   | USB data cords                              | USB 3.0 A male / A male cords           | 2 m                     | 0 514 01/0 398 59 <sup>(1)</sup> |
|   |   | USB 3.0 A male / B male cords           | 2 m                     | 0 514 02/0 398 60 <sup>(1)</sup> |
|   |   | USB 2.0 A male / Micro B male cord      | 1 m                     | 0 398 61 <sup>(1)</sup>          |
|   |   | USB 3.0 A male / Lightning male cord    | 1 m                     | 0 398 62 <sup>(1)</sup>          |
|   |   | USB 3.1 male Type-C / male Type-C cords | 1 m                     | 0 514 10/0 398 63 <sup>(1)</sup> |
|   |   | USB 2.0 male Type-C / male USB-A cords  | 2 m                     | 0 514 11/0 398 64 <sup>(1)</sup> |
|   | USB 2.0 male Type-C / USB male Micro B cord | 1 m                                     | 0 398 65 <sup>(1)</sup> |                                  |
| Adaptors  | USB 3.1 male Type-C / HDMI female           |   |                         | 0 514 12/0 398 66 <sup>(1)</sup> |
| RJ 45 CABLES  |   |   |                         |                                  |
|   | Cat. 6 U/UTP                                |   | 2 m                     | 0 398 74 <sup>(1)</sup>          |
|   |   |   | 5 m                     | 0 398 75 <sup>(1)</sup>          |
|   |   |   | 10 m                    | 0 398 76 <sup>(1)</sup>          |
|   |   |   | 15 m                    | 0 398 77 <sup>(1)</sup>          |
|   |   |   | 20 m                    | 0 398 78 <sup>(1)</sup>          |
|   |   |   | 30 m                    | 0 398 79 <sup>(1)</sup>          |
| CABLES FOR AUDIO/VIDEO APPLICATIONS                     |   |   |                         |                                  |
|   | VGA cable                                   |   | 20 m                    | 0 327 81                         |
|   | Loudspeaker cable                           |   | 15 m                    | 0 514 09                         |



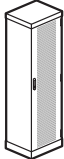
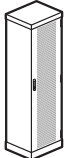

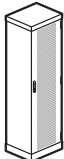

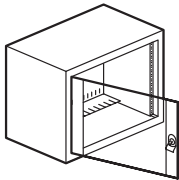
1: Supplied in a plastic bag with hook

## Legrand cabling system, LCS<sup>3</sup> enclosures selection chart

server cabinets, side panels, cabling and wall-mounting cabinets

| LCS <sup>3</sup> 19" SERVER CABINETS (WITHOUT SIDE PANELS)                            |      |              | Depth<br>1000 mm | Depth<br>1200 mm |
|---|------|--------------|------------------|------------------|
|      | 42 U | Width 600 mm | 4 464 00         | 4 464 01         |
|   | 42 U | Width 800 mm | 4 464 02         | 4 464 03         |
|   | 47 U | Width 600 mm | 4 464 04         | 4 464 05         |
|   | 47 U | Width 800 mm | 4 464 06         | 4 464 07         |
| LCS <sup>3</sup> 19" SERVER CABINETS (WITHOUT SIDE PANELS) - WITH AIR FLOW MANAGEMENT |      |              |                  |                  |
|      | 42 U | Width 600 mm | 4 464 10         | 4 464 11         |
|   | 42 U | Width 800 mm | 4 464 12         | 4 464 13         |
|   | 47 U | Width 600 mm | 4 464 14         | 4 464 15         |
|   | 47 U | Width 800 mm | 4 464 16         | 4 464 17         |
| LCS <sup>3</sup> 19" SIDE PANELS - SET OF 2, INCLUDING PLINTHS                        |      |              |                  |                  |
|      | 42 U | -            | 4 464 20         | 4 464 21         |
|   | 47 U | -            | 4 464 22         | 4 464 23         |
| LCS <sup>3</sup> 19" SERVER CABINETS - FLAT PACK (WITH SIDE PANELS)                   |      |              |                  |                  |
|     | 42 U | Width 800 mm | 4 464 25         | 4 464 26         |
| LCS <sup>3</sup> 19" CABLING CABINETS   |      |              | Depth<br>800 mm  | Depth<br>1000 mm |
|    | 24 U | Width 800 mm | 4 464 30         | 4 464 31         |
|   | 42 U | Width 800 mm | 4 464 32         | 4 464 33         |
|   | 47 U | Width 800 mm | 4 464 34         | 4 464 35         |
| LCS <sup>3</sup> 19" WALL-MOUNTING CABINETS   |      |              | Depth<br>525 mm  | Depth<br>625 mm  |
|    | 6 U  | Width 600 mm | 4 461 80         | -                |
|   | 9 U  | Width 600 mm | 4 461 81         | 4 461 82         |
|   | 12 U | Width 600 mm | 4 461 83         | 4 461 84         |
|   | 15 U | Width 600 mm | 4 461 85         | 4 461 86         |
|   | 21 U | Width 600 mm | -                | 4 461 87         |

## Legrand cabling system, LCS<sup>3</sup> Power Distribution Units selection chart

| BASIC POWER DISTRIBUTION UNITS (PDUS)   |                    |                                     |                  |          |          |          |
|---|--------------------|-------------------------------------|------------------|----------|----------|----------|
|    | IEC 60320 standard | 6 sockets (C19)                     | Aluminium 1U 19" | 3.7 kW   | Cordless | 6 468 07 |
|   |                    | 10 sockets (C13)                    | Aluminium 1U 19" | 3.7 kW   | Cordless | 6 468 44 |
|   |                    | 12 sockets (C13)                    | Aluminium 1U 19" | 3.7 kW   | 3 m cord | 6 468 15 |
|   |                    | 24 sockets (C13)                    | Aluminium Zero-U | 7.4 kW   | 3 m cord | 6 468 57 |
|   |                    |                                     |                  |          | Cordless | 6 468 56 |
|   |                    | 8 sockets (6 C13 + 2 C19)           | Aluminium 1U 19" | 3.7 kW   | 3 m cord | 6 468 09 |
|   |                    | 24 sockets (20 C13 + 4 C19)         | Aluminium Zero-U | 7.4 kW   | 3 m cord | 6 468 61 |
| Cordless  | 6 468 60           |                                     |                  |          |          |          |
| 24 sockets (18 C13 + 6 C19)   | Aluminium Zero-U   | 11 kW                               | 3 m cord         | 6 468 70 |          |          |
|   | French standard    | 4 sockets                           | Aluminium 1U 10" | 3.7 kW   | 1 m cord | 6 468 00 |
|   |                    | 6 sockets                           | Aluminium 19" 1U | 3.7 kW   | 3 m cord | 6 468 05 |
|   |                    | 6 sockets + MCB                     | Aluminium 1U 19" | 3.7 kW   | 3 m cord | 6 468 30 |
|   |                    | 6 sockets + RCBO                    | Aluminium 1U 19" | 3.7 kW   | 3 m cord | 6 468 33 |
|   |                    | 6 sockets + surge protection module | Aluminium 1U 19" | 3.7 kW   | 3 m cord | 6 468 35 |
|   |                    | 8 sockets                           | Aluminium 1U 19" | 3.7 kW   | 3 m cord | 6 468 22 |
|   |                    | 9 sockets                           | Aluminium 1U 19" | 3.7 kW   | 3 m cord | 6 468 10 |
|   |                    | 9 red tamperproof sockets           | Aluminium 1U 19" | 3.7 kW   | 3 m cord | 6 468 11 |
|   |                    | 9 sockets + power indicator         | Aluminium 1U 19" | 3.7 kW   | 3 m cord | 6 468 20 |
|   |                    | 24 sockets                          | Aluminium Zero-U | 7.4 kW   | 3 m cord | 6 468 51 |
|   |                    |                                     |                  |          | Cordless | 6 468 50 |
|  | German standard    | 4 sockets                           | Aluminium 1U 10" | 3.7 kW   | 1 m cord | 6 468 01 |
|   |                    | 6 sockets                           | Aluminium 1U 19" | 3.7 kW   | 3 m cord | 6 468 06 |
|   |                    | 6 sockets + MCB                     | Aluminium 1U 19" | 3.7 kW   | 3 m cord | 6 468 31 |
|   |                    | 6 sockets + surge protection module | Aluminium 1U 19" | 3.7 kW   | 3 m cord | 6 468 36 |
|   |                    | 8 sockets                           | Aluminium 1U 19" | 3.7 kW   | 3 m cord | 6 468 23 |
|   |                    | 9 sockets                           | Aluminium 1U 19" | 3.7 kW   | 3 m cord | 6 468 12 |
|   |                    | 9 sockets + power indicator         | Aluminium 1U 19" | 3.7 kW   | 3 m cord | 6 468 21 |
|   |                    | 9 sockets + MCB                     | Aluminium 2U 19" | 3.7 kW   | 3 m cord | 6 468 32 |
|   |                    | 24 sockets                          | Aluminium Zero-U | 7.4 kW   | 3 m cord | 6 468 53 |
|   |                    |                                     |                  |          | Cordless | 6 468 52 |
|  | British standard   | 6 sockets                           | Aluminium 1U 19" | 3 kW     | 3 m cord | 6 468 24 |
|   |                    | 8 sockets                           | Aluminium 1U 19" | 3 kW     | 3 m cord | 6 468 13 |
|   |                    | 24 sockets                          | Aluminium Zero-U | 7.4 kW   | Cordless | 6 468 54 |
|  | Italian standard   | 24 sockets                          | Aluminium Zero-U | 7.4 kW   | 3 m cord | 6 468 59 |
|  | Swiss standard     | 12 sockets (T13)                    | Aluminium 1U 19" | 3.7 kW   | 3 m cord | 6 468 18 |
|   |                    | 12 sockets (T23)                    | Aluminium 1U 19" | 3.7 kW   | 3 m cord | 6 468 19 |

## Legrand cabling system, LCS<sup>3</sup> cat. 8

flat patch panels - equipped and to be equipped

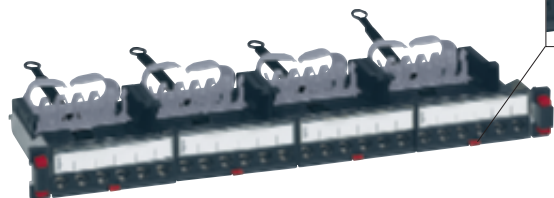

0 337 82

Automatic cassette removal



Equipped with new-generation Quick-Fix for automatic (screwless) mounting on enclosure and cabinet uprights  
 Universal mounting on all cabinets or enclosures  
 Panels ensure automatic earthing of each connector  
 Equipped with 4 bundles guides fixed at the rear

| Pack | Cat.Nos  |   |
|------|----------|---|
| 1    | 0 337 82 | <b>Cat. 8 patch panel equipped with 24 RJ 45 connectors</b><br>19" panel - 1U<br>Equipped with 4 cassettes of 6 pre-fitted Cat. 8 LCS <sup>3</sup> RJ 45 connectors<br>Automatic cassette removal by simple pressure<br>Each connector can be removed individually<br>T568A and B marking with colour codes<br>Equipped with rear cable guide to hold cable during maintenance<br>Supplied with coloured labels<br>Compliant with ISO/IEC 11 801, EN 50173 and ANSI/TIA 568 standards<br><b>Flat panel</b><br>STP panel - Metal shielding - PoE++ |
|      |          | <b>Patch panels 24 connectors - to be equipped</b><br>19" panels - 1U<br>Equipped with rear cable guide to hold cables during maintenance   |
| 1    | 0 337 90 | <b>Flat panel with empty cassettes to be equipped with connectors</b><br>With 4 automatically removable cassettes to be equipped with Cat. 5e to Cat. 8 RJ 45 connectors  |
| 1    | 0 337 91 | <b>Flat panel without connectors to be equipped with cassettes</b><br>Can take a maximum of 4 automatically removable cassettes:<br>- copper to be equipped with Cat. 5e to Cat. 8 RJ 45 connectors<br>- fiber optic  |

## Legrand cabling system, LCS<sup>3</sup> cat. 8

angled patch panel to be equipped with connectors



0 337 92

| Pack | Cat.Nos  |   |
|------|----------|---|
| 1    | 0 337 92 | <b>Angled patch panel with 24 connectors</b><br>19" panel - 1U<br>Equipped with new-generation Quick-Fix for automatic mounting (screwless) on cabinet and enclosure uprights<br>Universal mounting on all cabinets or enclosures<br>Panels ensure automatic earthing of each connector<br>Equipped with rear cable guide to hold cables during maintenance<br><b>Angled patch panel to be equipped with connectors</b><br>Can take up to 24 Cat. 5e to Cat. 8 RJ 45 connectors |

## Legrand cabling system, LCS<sup>3</sup> cat. 8

### connector, cords and cables

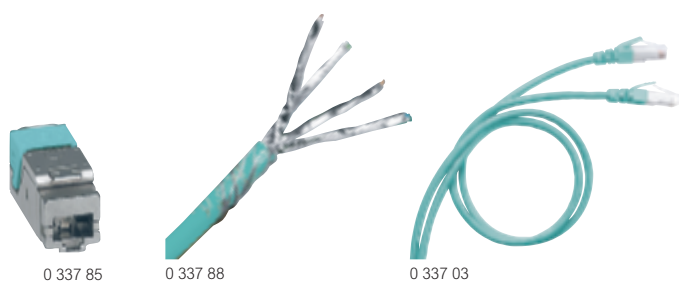

0 337 85

0 337 88

0 337 03

| Pack             | Cat.Nos   |   |
|------------------|---|---|
| 6                | 0 337 85  | <b>Cat. 8 RJ 45 connector for flat or angled STP panel</b><br>Set of 6 STP RJ 45 Quick-connect connectors (no tools required)<br>T568A and B marking with colour codes<br>Compliant with ISO/IEC 11 801, EN 50173 and ANSI/TIA 568 standards<br>To be installed in cassettes for flat panels or directly in an angled panel or a zone distribution box to be equipped |
| 500 <sup>1</sup> | 0 337 88  | <b>Cat. 8 cable for local networks</b><br>Performance 2000 MHz<br>Cable with 4 twisted pairs 100 Ω<br>LSZH sheath: zero halogen<br>EIA/TIA colour code<br>Compliant with ISO/IEC 11 801, EN 50173 and ANSI/TIA 568 standards<br>Product conforming to the CPR regulations<br><b>S/FTP - 4 pairs</b><br>Length 500 m, supplied on a drum<br>Weight 45 kg               |
| 1<br>1           | LSZH<br><br>RAL 6027<br>0 337 03<br>0 337 04 | <b>Cat. 8 RJ 45 patch cords</b><br>RJ 45/RJ 45 - straight<br>Compliant with ISO/CEI 11801 and EIA/TIA 568 standards<br><b>Shielded S/FTP, impedance 100 Ω</b><br>Length 2 m<br>Length 3 m   |
| 200              | 0 518 90  | <b>Marking kit</b><br>Kit of 200 coloured rings for marking RJ 45 cords<br>4 colors (green/red/yellow/blue). 50 pieces of each color<br>Rings to be clipped onto the patch cords  |

1: in metre(s)

## Legrand cabling system, LCS<sup>3</sup> cat. 8

### accessories



0 337 56

0 337 59

0 337 55

0 337 66

0 337 57

0 337 58

| Pack | Cat.Nos  |   |
|------|----------|---|
| 10   | 0 337 56 | <b>Common accessories for flat and angled panels</b><br><b>Port blanking modules</b><br>Separable blanking plate<br>For covering 1 to 6 ports or 1 to 12 ports individually (High Density solutions)  |
| 1    | 0 337 59 | <b>Cord management</b><br>2 cable guides to be clipped onto new-generation Quick-Fix<br>Provide side cord management<br>Label-holder for identification   |
| 1    | 0 337 55 | <b>Specific accessories for flat panels</b><br><b>Cassette for flat panels to be equipped</b><br>Removable empty cassette to be equipped with connectors, takes 6 Cat. 5e to Cat. 8 connectors<br>Can be removed by simple pressing on the cassette, for ease of installation and maintenance<br>For equipping flat panels<br><b>Cassette with shutters for flat panels to be equipped</b><br>Removable empty cassette to be equipped with connectors, takes 6 Cat. 5e to Cat. 8 connectors<br>Can be removed by simple pressing on the cassette, for ease of installation and maintenance<br>Equipped with 6 individual shutters to protect RJ 45 connectors contacts<br>For equipping flat panels<br><b>Blanking cassette</b><br>To be used to fill gaps in the panel |
| 1    | 0 337 57 | <b>Specific accessory for angled panels</b><br><b>Cover</b><br>Optimises air flow management in the enclosure   |

## Legrand cabling system, LCS<sup>3</sup> cat. 6A

### flat patch panels - equipped

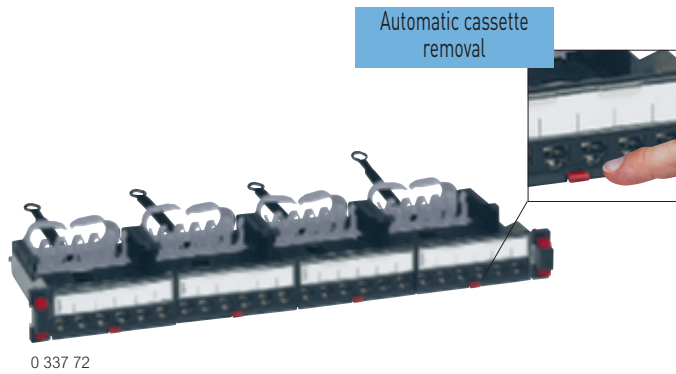

Equipped with new-generation Quick-Fix for automatic (screwless) mounting on enclosure and cabinet uprights  
 Universal mounting on all cabinets or enclosures  
 Panels ensure automatic earthing of each connector  
 Equipped with 4 bundles guides fixed at the rear

| Pack | Cat.Nos  | <b>Cat. 6A patch panels equipped with 24 RJ 45 connectors</b>  |
|------|----------|--|
|      |          | 19" panel - 1U<br>Equipped with 4 cassettes of 6 pre-fitted Cat. 6A LCS <sup>3</sup> RJ 45 connectors<br>Automatic cassette removal by simple pressure<br>Each connector can be removed individually<br>T568A and B marking with colour codes<br>Equipped with rear cable guide to hold cables during maintenance<br>Supplied with coloured labels<br>Compliant with ISO/IEC 11 801, EN 50173 and ANSI/TIA 568 standards |
|      |          | <b>Flat panels</b><br>24 RJ 45 connectors - 1U - PoE++   |
| 1    | 0 337 70 | UTP  |
| 1    | 0 337 72 | STP  |

## Legrand cabling system, LCS<sup>3</sup> cat. 6A

### flat patch panels, to be equipped

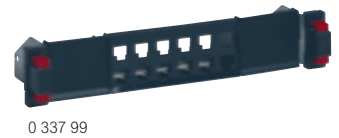
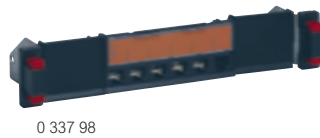
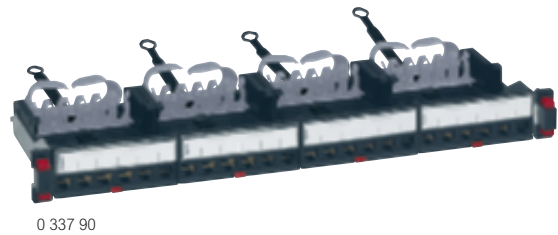

Equipped with new-generation Quick-Fix for automatic (screwless) mounting on enclosure and cabinet uprights  
 Universal mounting on all cabinets or enclosures  
 Panels ensure automatic earthing of each connector  
 Equipped with 4 bundles guides fixed at the rear

| Pack | Cat.Nos  | <b>19" flat patch panels - to be equipped</b>  |
|------|----------|--|
|      |          | 19" panels - 1U<br>Equipped with rear cable guide to hold cables during maintenance<br>Automatic cassette removal by simple pressure<br>Each connector can be removed individually                   |
| 1    | 0 337 90 | <b>Flat panel with empty cassettes to be equipped with connectors</b><br>Equipped with 4 automatically removable cassettes, takes up to 24 Cat. 5e to Cat. 8 RJ 45 connectors                        |
| 1    | 0 337 91 | <b>Empty flat panel to be equipped with cassettes</b><br>Takes a maximum of 4 automatically removable cassettes:<br>- copper to be equipped with Cat. 5e to Cat. 8 RJ 45 connectors<br>- fiber optic |
| 1    | 0 337 93 | <b>High Density flat panel with empty cassettes to be equipped with connectors</b><br>Equipped with 4 High Density cassettes, takes up to 48 Cat. 5e to Cat. 6A RJ 45 connectors                     |
|      |          | <b>10" flat patch panels - to be equipped</b>  |
| 1    | 0 337 98 | 10" panels - 1U<br>Takes up to 6 Cat. 5e to Cat. 8 RJ 45 connectors  |
| 1    | 0 337 99 | Takes up to 12 Cat. 5e to Cat. 6A RJ 45 connectors   |

## Legrand cabling system, LCS<sup>3</sup> cat. 6A

### angled patch panels to be equipped, connectors



0 337 92



0 337 94



0 337 75



Equipped with new-generation Quick-Fix for automatic (screwless) mounting on enclosure and cabinet uprights.  
 Universal mounting on all cabinets or enclosures  
 Panels ensure automatic earthing of each connector  
 Equipped with 4 concentric strand guides fixed at the rear

| Pack | Cat.Nos  | Angled patch panels - to be equipped  |
|------|----------|---|
|      |          | 19" panels - 1U   |
| 1    | 0 337 92 | <b>Angled patch panel to be equipped with connectors</b><br>Takes up to 24 Cat. 5e to Cat. 8 RJ 45 connectors   |
| 1    | 0 337 94 | <b>High Density angled panel to be equipped with connectors</b><br>Takes up to 48 Cat. 5e to Cat. 6A RJ 45 connectors   |
|      |          | <b>Cat. 6A High Density RJ 45 connectors</b><br>Quick-connect connection (no tools required)<br>T568A and B marking with colour codes<br>Compliant with ISO/IEC 11 801, EN 50173 and ANSI/TIA 568 standards<br>To be installed in cassettes for flat panels or directly in an angled panel or a zone distribution box to be equipped<br>Set of 6 RJ 45 connectors |
| 6    | 0 337 73 | UTP   |
| 6    | 0 337 75 | STP   |

## Legrand cabling system, LCS<sup>3</sup> cat. 6A

### accessories



0 337 56

0 337 59

0 337 55

0 337 66



0 337 57



0 337 58

| Pack | Cat.Nos  | Common accessories for flat and angled panels   |
|------|----------|---|
| 10   | 0 337 56 | <b>Port blanking modules</b><br>Separable blanking plate<br>For covering 1 to 6 ports or 1 to 12 ports individually (High Density solutions)  |
| 1    | 0 337 59 | <b>Cord management</b><br>2 cable guides to be clipped onto new-generation Quick-Fix<br>Provide side cord management<br>Label-holder for identification   |
|      |          | <b>Specific accessories for flat panels</b>   |
| 1    | 0 337 55 | <b>Cassette for flat panels to be equipped</b><br>Removable empty cassette to be equipped with connectors, takes 6 Cat. 5e to Cat. 8 connectors<br>Can be removed by simple pressing on the cassette, for ease of installation and maintenance<br>For equipping flat panels   |
| 1    | 0 337 66 | <b>Cassette with shutters for flat panels to be equipped</b><br>Removable empty cassette to be equipped with connectors, takes 6 Cat. 5e to Cat. 8 connectors<br>Can be removed by simple pressing on the cassette, for ease of installation and maintenance<br>Equipped with 6 individual shutters to protect RJ 45 connectors contacts<br>For equipping flat panels |
| 1    | 0 337 95 | <b>High Density cassette for flat panels to be equipped</b><br>Removable empty cassette to be equipped with connectors, takes 12 Cat. 5e to Cat. 6A connectors<br>Can be removed by simple pressing on the cassette, for ease of installation and maintenance<br>For equipping flat panels  |
| 1    | 0 337 57 | <b>Blanking cassette</b><br>To be used to fill gaps in the panel  |
|      |          | <b>Specific accessory for angled panels</b>   |
| 1    | 0 337 58 | <b>Cover</b><br>Optimises air flow management in the enclosure  |

# Legrand cabling system, LCS<sup>3</sup> cat. 6A and cat. 7

## cables and cords

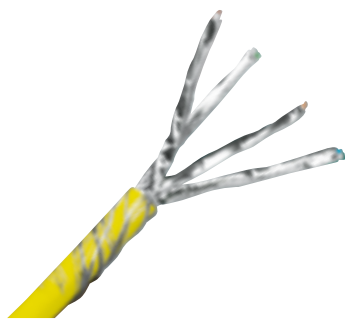

0 327 77

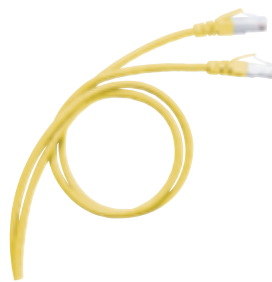

0 517 82

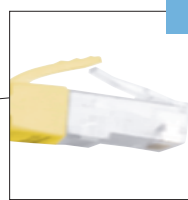

Easy grip

| Pack             | Cat.Nos  | Cat. 6A cables for local networks  |
|------------------|----------|--|
|                  |          | Performance 500 MHz<br>4 twisted pair cables, 100 Ω<br>LSZH sheath: zero halogen<br>ANSI/TIA colour code<br>Compliant with ISO/IEC 11 801, EN 50173 and ANSI/TIA 568 standards<br>Products conforming to the CPR regulations |
|                  |          | <b>U/UTP - 4 pairs</b>   |
| 500 <sup>1</sup> | 0 327 87 | Length 500 m. Supplied on reel. Weight 35 kg<br>Euroclass Dca  |
| 500 <sup>1</sup> | 0 328 28 | Length 500m. Supplied on reel. Weight 36 kg<br>Euroclass Cca   |
| 500 <sup>1</sup> | 0 328 38 | Length 500m. Supplied on reel. Weight 33kg<br>Euroclass B2ca   |
|                  |          | <b>F/UTP - 4 pairs</b>   |
| 500 <sup>1</sup> | 0 327 78 | Length 500 m. Supplied on reel. Weight 29.2 kg<br>Euroclass Dca  |
|                  |          | <b>F/UTP - 2 x 4 pairs</b>   |
| 500 <sup>1</sup> | 0 328 78 | Length 500 m. Supplied on reel. Weight 58 kg<br>Euroclass Dca  |
|                  |          | <b>F/FTP - 4 pairs</b>   |
| 500 <sup>1</sup> | 0 328 83 | Length 500 m. Supplied on reel. Weight 32 kg<br>Euroclass Cca  |
| 500 <sup>1</sup> | 0 327 99 | Length 500 m. Supplied on reel. Weight 26 kg<br>Euroclass Dca  |
|                  |          | <b>F/FTP - 2 x 4 pairs</b>   |
| 500 <sup>1</sup> | 0 327 98 | Length 500 m. Supplied on reel. Weight 62 kg<br>Euroclass Dca  |
|                  |          | <b>U/FTP - 4 pairs</b>   |
| 500 <sup>1</sup> | 0 328 84 | Length 500 m. Supplied on reel. Weight 39 kg<br>Euroclass Cca  |

| Pack             | Cat.Nos  | Cat. 7 cables for local networks   |
|------------------|----------|--|
|                  |          | Performance 600 MHz<br>4 twisted pair cables, 100 Ω<br>LSZH sheath: zero halogen<br>ANSI/TIA colour code<br>Compliant with ISO/IEC 11 801 and EN 50173 standards<br>Products conforming to the CPR regulations |
|                  |          | <b>S/FTP - 4 pairs</b>   |
| 500 <sup>1</sup> | 0 328 82 | Length 500 m. Supplied on reel. Weight 33 kg<br>Euroclass B2 ca  |
| 500 <sup>1</sup> | 0 328 49 | Length 500m. Supplied on reel. Weight 31 kg<br>Euroclass Cca   |
| 500 <sup>1</sup> | 0 327 77 | Length 500 m. Supplied on reel. Weight 30 kg<br>Euroclass Dca  |
|                  |          | <b>S/FTP - 2 x 4 pairs</b>   |
| 500 <sup>1</sup> | 0 327 79 | Length 500 m. Supplied on reel. Weight 63 kg<br>Euroclass Dca  |

| Pack             | Cat.Nos  | Cat. 7 indoor/outdoor cable for local networks   |
|------------------|----------|--|
|                  |          | Performance 600 MHz<br>4 twisted pair cable, 100 Ω<br>LSZH sheath: zero halogen<br>ANSI/TIA colour code<br>Compliant with ISO/IEC 11 801 and EN 50173 standards<br>Product conforming to the CPR regulations |
|                  |          | <b>S/FTP - 4 pairs - indoor/outdoor</b>  |
| 500 <sup>1</sup> | 0 338 90 | Length 500 m. Supplied on reel. Weight 26 kg<br>Euroclass Eca  |

| Pack | Cat.Nos  | Cat. 6A RJ 45 patch cords and user cords  |
|------|----------|---|
|      |          | RJ 45/RJ 45 - flat<br>With special "easy grip" plug<br>Compliant with ISO/IEC 11 801, EN 50173 and ANSI/TIA 568 standards |
|      |          | <b>Unscreened U/UTP, impedance 100 Ω</b>  |
|      |          | <b>PVC</b>  |
| 1    | 0 518 82 | Length 1 m  |
| 1    | 0 518 83 | Length 2 m  |
| 1    | 0 518 84 | Length 3 m  |
| 1    | 0 518 85 | Length 5 m  |
|      |          | <b>LSZH</b>   |
| 1    | 0 518 78 | Length 1 m  |
| 1    | 0 518 79 | Length 2 m  |
| 1    | 0 518 80 | Length 3 m  |
| 1    | 0 518 81 | Length 5 m  |
| 1    | 0 518 74 | Length 1 m  |
| 1    | 0 518 75 | Length 2 m  |
| 1    | 0 518 76 | Length 3 m  |
| 1    | 0 518 77 | Length 5 m  |
|      |          | <b>PVC</b>  |
| 1    | 0 518 48 | Length 0.3 m  |
| 1    | 0 518 16 | Length 0.5 m  |
| 5    | 0 517 80 | Length 1 m  |
| 5    | 0 517 81 | Length 2 m  |
| 5    | 0 517 82 | Length 3 m  |
| 5    | 0 517 83 | Length 5 m  |
| 1    | 0 518 49 | Length 10 m   |
|      |          | <b>LSZH</b>   |
| 1    | 0 518 70 | Length 1 m  |
| 1    | 0 518 71 | Length 2 m  |
| 1    | 0 518 72 | Length 3 m  |
| 1    | 0 518 73 | Length 5 m  |
| 1    | 0 518 66 | Length 1 m  |
| 1    | 0 518 67 | Length 2 m  |
| 1    | 0 518 68 | Length 3 m  |
| 1    | 0 518 69 | Length 5 m  |

| Pack | Cat.Nos  | Cat. 6A RJ 45 patch cords and user cords - High Density   |
|------|----------|---|
|      |          | RJ 45/RJ 45 - flat<br>With special "easy grip" plug<br>Compliant with ISO/IEC 11 801, EN 50173 and ANSI/TIA 568 standards |
|      |          | <b>Shielded S/FTP, impedance 100 Ω</b>  |
|      |          | <b>LSZH</b>   |
| 1    | 0 515 50 | Length 0.5 m  |
| 1    | 0 515 51 | Length 1 m  |
| 1    | 0 515 52 | Length 2 m  |
| 1    | 0 515 53 | Length 3 m  |
| 1    | 0 515 54 | Length 5 m  |

| Pack | Cat.Nos  | Marking kit  |
|------|----------|--|
| 200  | 0 518 90 | Kit of 200 coloured rings for marking RJ 45 cords<br>4 colors (green/red/yellow/blue). 50 pieces of each color<br>Rings to be clipped onto the patch cords |

1: in metre(s)



## Legrand cabling system, LCS<sup>3</sup> cat. 6A

### RJ 45 sockets - Mosaic™



Can be integrated in any support  
Mechanisms to be equipped with support frames and plates  
Equipped with connectors with quick toolless connection  
Take single-core cables from AWG 22 up to AWG 26, and AWG 26 multicore cables  
T568A and B marking with colour codes  
Compliant with ISO/IEC 11 801, EN 50173 and ANSI/TIA 568 standards

## Legrand cabling system, LCS<sup>3</sup> cat. 6A

### RJ 45 sockets - Arteor



Can be integrated in any support  
Mechanisms to be equipped with support frames and plates  
Equipped with connectors with quick toolless connection  
Take single-core cables from AWG 22 up to AWG 26, and AWG 26 multicore cables  
T568A and B marking with colour codes  
Compliant with ISO/IEC 11 801, EN 50173 and ANSI/TIA 568 standards

| Pack | Cat.Nos   | Cat. 6A RJ 45 sockets - Mosaic   |
|------|-----------|--|
| 10   | 0 765 73  | <b>STP - 1 module</b><br>Metal shielding   |
| 10   | 0 765 84  | ○ White  |
| 10   | 0 794 73  | ○ White antimicrobial <sup>(1)</sup>   |
| 10   | 0 791 73L | ● Aluminium  |
|      |           | ● Matt Black   |
| 10   | 0 765 76  | <b>STP - 2 modules</b><br>Metal shielding  |
| 10   | 0 794 76  | ○ White  |
| 10   | 0 791 76L | ● Aluminium  |
| 10   | 0 765 24  | ● Matt Black   |
|      |           | ○ White with green shutter   |
| 10   | 0 765 25  | ○ White with orange shutter  |
| 5    | 0 765 99  | <b>STP with controlled access - 2 modules</b><br>Metal shielding<br>Supplied with 2 keys for 5 sockets |
|      |           | ○ White with red shutter   |
| 10   | 0 765 08  | <b>STP 45° - 2 modules</b><br>Metal shielding  |
|      |           | ○ White  |
| 10   | 0 765 71  | <b>UTP - 1 module</b>  |
| 10   | 0 794 71  | ○ White  |
| 10   | 0 765 26  | ● Aluminium  |
| 10   | 0 765 27  | ○ White with green shutter   |
|      |           | ○ White with orange shutter  |
| 10   | 0 765 74  | <b>UTP - 2 modules</b>   |
| 10   | 0 794 74  | ○ White  |
|      |           | ● Aluminium  |
| 5    | 0 765 90  | <b>UTP with controlled access - 2 modules</b><br>Supplied with 2 keys for 5 sockets                    |
|      |           | ○ White with red shutter   |
| 10   | 0 765 09  | <b>UTP 45° - 2 modules</b>   |
|      |           | ○ White  |

1: Contains a silver compound which prevents the growth of bacteria on the surface

| Pack | Cat.Nos  | Cat. 6A RJ 45 sockets - Arteor  |
|------|----------|---|
| 10   | 5 723 06 | Metal shielding   |
| 10   | 5 728 06 | <b>STP - 1 module</b>   |
| 10   | 5 728 46 | ○ White   |
| 10   | 5 728 45 | ● Magnesium   |
| 10   | 5 723 51 | ● Champagne   |
| 10   | 5 728 51 | ● Soft Alu  |
| 10   | 5 728 48 | ○ White with orange shutter   |
| 10   | 5 728 47 | ● Magnesium with orange shutter   |
| 10   | 5 728 47 | ● Champagne with orange shutter   |
| 10   | 5 723 52 | ● Soft Alu with orange shutter  |
| 10   | 5 728 52 | ○ White with green shutter  |
| 10   | 5 728 61 | ● Magnesium with green shutter  |
| 10   | 5 728 60 | ● Champagne with green shutter  |
|      |          | ● Soft Alu with green shutter   |
| 5    | 5 723 50 | <b>STP with controlled access - 2 modules</b><br>Supplied with 2 keys for 5 sockets |
| 5    | 5 728 50 | ○ White with red shutter  |
| 5    | 5 728 63 | ● Magnesium with red shutter  |
| 5    | 5 728 62 | ● Champagne with red shutter  |
|      |          | ● Soft Alu with red shutter   |
| 10   | 5 723 49 | <b>UTP - 1 module</b>   |
| 10   | 5 728 49 | ○ White   |
| 10   | 5 728 65 | ● Magnesium   |
| 10   | 5 728 64 | ● Champagne   |
| 10   | 5 723 58 | ● Soft Alu  |
| 10   | 5 728 58 | ○ White with orange shutter   |
| 10   | 5 728 69 | ● Magnesium with orange shutter   |
| 10   | 5 728 68 | ● Champagne with orange shutter   |
| 10   | 5 723 59 | ● Soft Alu with orange shutter  |
| 10   | 5 728 59 | ○ White with green shutter  |
| 10   | 5 728 67 | ● Magnesium with green shutter  |
| 10   | 5 728 66 | ● Champagne with green shutter  |
|      |          | ● Soft Alu with green shutter   |
| 5    | 5 723 57 | <b>UTP with controlled access - 2 modules</b><br>Supplied with 2 keys for 5 sockets |
| 5    | 5 728 57 | ○ White with red shutter  |
| 5    | 5 728 72 | ● Magnesium with red shutter  |
| 5    | 5 728 71 | ● Champagne with red shutter  |
|      |          | ● Soft Alu with red shutter   |

## Legrand cabling system, LCS<sup>3</sup> cat. 6A

other RJ 45 connectors



6 327 79



0 337 49



0 695 59

| Pack | Cat.Nos  | Cat. 6A Keystone RJ 45 sockets   |
|------|----------|--|
| 10   | 0 331 54 | STP socket - metal shielding with quick toolless connection  |
| 10   | 0 331 55 | UTP connector - with quick toolless connection   |
| 1    | 6 327 79 | <b>Surface mounting box - 1 or 2 ports</b><br>For Keystone connectors<br>For surface mounting installations<br>Can be fixed to a table or used in conjunction with mini-trunking |
| 1    | 0 337 43 | <b>STP Cat. 6A cable extender</b><br>To be used to extend a cable quickly and easily   |
| 1    | 0 337 49 | <b>STP Cat. 6A field plug</b><br>To be used to make a direct connection on any IP equipment (switch, PoE LED panel, camera, Wi-Fi access point, etc)<br>No tools required        |
| 5    | 0 695 59 | <b>STP Cat. 6A Plexo RJ 45 socket</b><br>IP 55 closed flap IK 07<br>● Grey   |



## Legrand cabling system, LCS<sup>3</sup> cat. 6A

zone distribution box solution



0 337 97



0 337 75



0 786 28

| Pack | Cat.Nos  | Zone distribution boxes to be equipped   |
|------|----------|--|
| 1    | 0 337 96 | For distributing data in an area equipped with 1 to 24 RJ 45 sockets<br>Centralise connections to ensure flexibility and scalability of the installation<br>For installation in false ceilings or raised access floors<br>The boxes connect to the patching enclosure or floor cabinet<br>Connection to an RJ 45 socket with an RJ 45/stripped cord or to a Mosaic RJ 45 socket with copper feedthrough with an RJ 45/RJ 45 cord<br>IP 21 - IK 07<br>Compliant with ISO/IEC 11 801, EN 50173 and ANSI/TIA 568 standards<br>T568A and B marking with colour codes<br>Technical characteristics: polycarbonate cover (PC), polypropylene base (PP), RAL 7035<br>To be equipped directly with High Density RJ 45 connectors |
| 1    | 0 337 97 | 12 ports to be equipped<br>24 ports to be equipped   |
| 6    | 0 337 73 | <b>Cat. 6A High Density RJ 45 connectors</b><br>Set of 6 RJ 45 connectors  |
| 6    | 0 337 75 | UTP<br>STP   |
| 1    | 0 517 86 | <b>Cat. 6A cords - RJ 45/stripped</b><br>RJ 45/stripped - straight<br>Plug in and out of the zone distribution boxes and connect to an LCS <sup>3</sup> connector of an RJ 45 socket via the stripped side<br>Cables prepared in factory, "ready for wiring"<br>Compliant with ISO/IEC 11801 Ed. 2.0 (2011), EN 50173-1 and EIA/TIA 568 C2 standards   |
| 1    | 0 517 87 | <b>Shielded S/FTP, impedance 100 Ω</b><br>Length 8 m   |
| 1    | 0 517 88 | Length 15 m  |
| 1    | 0 517 88 | Length 20 m  |
| 1    | 0 515 23 | <b>Cat. 6A cords - RJ 45/RJ 45</b><br>For direct connection via RJ 45 male plug to the zone distribution box and to the RJ 45 socket with copper feedthrough to ensure safe connection, plus speed and reliability of connection<br>Compliant with ISO/IEC 11 801, EN 50173 and ANSI/TIA 568 standards   |
| 1    | 0 515 24 | <b>Shielded S/FTP, impedance 100 Ω</b><br>Length 8 m   |
| 1    | 0 515 25 | Length 15 m  |
| 1    | 0 515 25 | Length 20 m  |
| 10   | 0 786 28 | <b>Cat. 6A sockets with copper feedthrough</b><br><b>Cat. 6A STP - Mosaic</b><br>○ White   |
| 10   | 0 786 29 | ● Aluminium  |



LSZH  
RAL 1018



LSZH  
RAL 1018



## Legrand cabling system, LCS<sup>3</sup> cat. 6

### flat patch panels - equipped

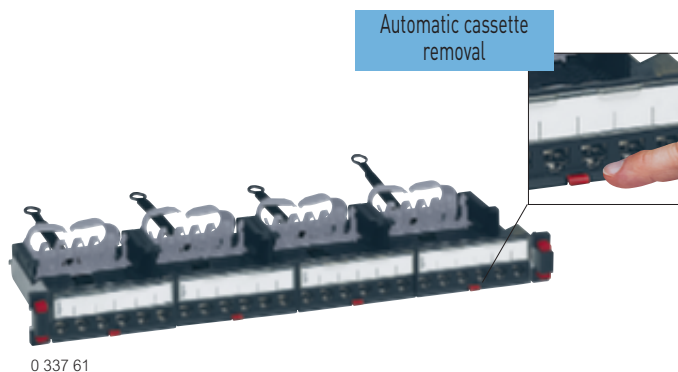

Equipped with new-generation Quick-Fix for automatic (screwless) mounting on enclosure and cabinet uprights  
 Universal mounting on all cabinets or enclosures  
 Panels ensure automatic earthing of each connector  
 Equipped with 4 bundles guides fixed at the rear

| Pack | Cat.Nos  | <b>Cat. 6 patch panels equipped with 24 RJ 45 connectors</b>  |
|------|----------|---|
|      |          | 19" panels - 1U<br>Equipped with 4 cassettes of 6 pre-fitted Cat. 6 LCS <sup>3</sup> RJ 45 connectors<br>Automatic cassette removal by simple pressure<br>Each connector can be removed individually<br>T568A and B marking with colour codes<br>Equipped with rear cable guide to hold cables during maintenance<br>Supplied with numbered colour labels<br>Compliant with ISO/IEC 11 801, EN 50173 and ANSI/TIA 568 standards |
|      |          | <b>Flat panels</b>  |
|      |          | 24 RJ 45 connectors - 1U - PoE++  |
| 1    | 0 337 60 | UTP   |
| 1    | 0 337 61 | FTP   |
| 1    | 0 337 62 | STP   |

## Legrand cabling system, LCS<sup>3</sup> cat. 6

### flat patch panels, to be equipped

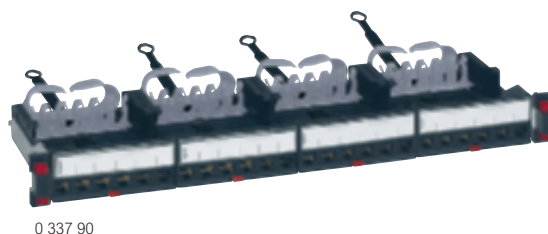

0 337 90



0 337 98

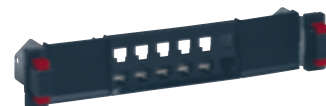

0 337 99

Equipped with new-generation Quick-Fix for automatic (screwless) mounting on enclosure and cabinet uprights  
 Universal mounting on all cabinets or enclosures  
 Panels ensure automatic earthing of each connector  
 Equipped with 4 bundles guides fixed at the rear

| Pack | Cat.Nos  | <b>19" flat patch panels - to be equipped</b>  |
|------|----------|--|
|      |          | 19" panels - 1U<br>Equipped with rear cable guide to hold cables during maintenance<br>Automatic cassette removal by simple pressure<br>Each connector can be removed individually |
|      |          | <b>Flat panel with empty cassettes to be equipped with connectors</b>  |
| 1    | 0 337 90 | Equipped with 4 automatically removable cassettes, takes up to 24 Cat. 5e to Cat. 8 RJ 45 connectors   |
|      |          | <b>Empty flat panel to be equipped with cassettes</b>  |
|      |          | Can take a maximum of 4 automatically removable cassettes:   |
|      |          | - copper to be equipped with Cat. 5e to Cat. 8 RJ 45 connectors  |
|      |          | - fiber optic  |
|      |          | <b>High Density flat panel with empty cassettes to be equipped with connectors</b>   |
| 1    | 0 337 93 | Equipped with 4 High Density cassettes, takes up to 48 Cat. 5e to Cat. 6A RJ 45 connectors   |
|      |          | <b>10" flat patch panels - to be equipped</b>  |
|      |          | 10" panels - 1U  |
| 1    | 0 337 98 | Takes up to 6 Cat. 5e to Cat. 8 RJ 45 connectors   |
| 1    | 0 337 99 | Takes up to 12 Cat. 5e to Cat. 6A RJ 45 connectors   |

## Legrand cabling system, LCS<sup>3</sup> cat. 6

### angled patch panels to be equipped, connectors



0 337 92



0 337 94



0 337 63



Equipped with new-generation Quick-Fix for automatic (screwless) mounting on enclosure and cabinet uprights  
 Universal mounting on all cabinets or enclosures  
 Panels ensure automatic earthing of each connector  
 Equipped with 4 concentric strand guides fixed at the rear

| Pack | Cat.Nos  | Angled patch panels - to be equipped   |
|------|----------|--|
|      |          | 19" panels - 1U  |
| 1    | 0 337 92 | <b>Angled patch panel to be equipped with connectors</b><br>Takes up to 24 Cat. 5e to Cat. 8 RJ 45 connectors  |
| 1    | 0 337 94 | <b>High Density angled panel to be equipped with connectors</b><br>Takes up to 48 Cat. 5e to Cat. 6A RJ 45 connectors  |
|      |          | <b>Cat. 6 High Density RJ 45 connectors</b>  |
|      |          | Quick-connect connection (no tools required)<br>T568A and B marking with colour codes<br>Compliant with ISO/IEC 11 801, EN 50173 and ANSI/TIA 568 standards<br>To be installed in cassettes for flat panels or directly in an angled panel or a zone distribution box to be equipped |
| 6    | 0 337 63 | UTP  |
| 6    | 0 337 64 | FTP  |
| 6    | 0 337 65 | STP  |

## Legrand cabling system, LCS<sup>3</sup> cat. 6

### accessories



0 337 56



0 337 59



0 337 55



0 337 66



0 337 57



0 337 58

| Pack | Cat.Nos  | Common accessories for flat and angled panels   |
|------|----------|---|
| 10   | 0 337 56 | <b>Port blanking plate</b><br>Separable blanking plate<br>For covering 1 to 6 ports or 1 to 12 ports individually (High Density solutions)  |
| 1    | 0 337 59 | <b>Cord management</b><br>2 cable guides to be clipped onto new-generation Quick-Fix<br>Provide side cord management<br>Label-holder for identification   |
|      |          | <b>Specific accessories for flat panels</b>   |
| 1    | 0 337 55 | <b>Cassette for flat panels to be equipped</b><br>Removable empty cassette to be equipped with connectors, takes 6 Cat. 5e to Cat. 8 connectors<br>Can be removed by simple pressing on the cassette, for ease of installation and maintenance<br>For equipping flat panels   |
| 1    | 0 337 66 | <b>Cassette with shutters for flat panels to be equipped</b><br>Removable empty cassette to be equipped with connectors, takes 6 Cat. 5e to Cat. 8 connectors<br>Can be removed by simple pressing on the cassette, for ease of installation and maintenance<br>Equipped with 6 individual shutters to protect RJ 45 connectors contacts<br>For equipping flat panels |
| 1    | 0 337 95 | <b>High Density cassette for flat panels to be equipped</b><br>Removable empty cassette to be equipped with connectors, takes 12 Cat. 5e to Cat. 6A connectors<br>Can be removed by simple pressing on the cassette, for ease of installation and maintenance<br>For equipping flat panels  |
| 1    | 0 337 57 | <b>Blanking cassette</b><br>To be used to fill gaps in the panel  |
|      |          | <b>Specific accessory for angled panels</b>   |
| 1    | 0 337 58 | <b>Cover</b><br>Optimises air flow management in the enclosure  |

# Legrand cabling system, LCS<sup>3</sup> cat. 6

## cables and cords

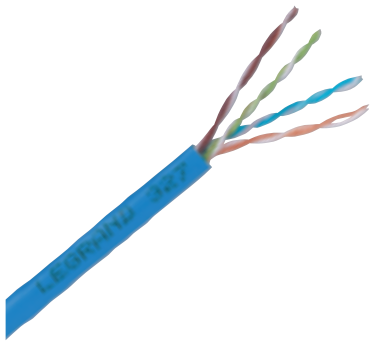

0 327 54

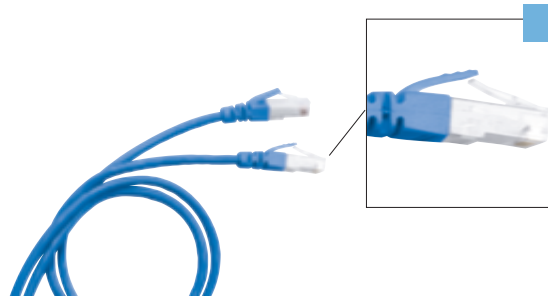

0 517 54

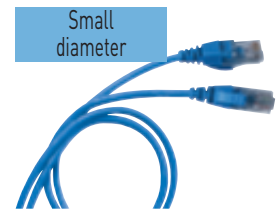

0 515 41

| Pack             | Cat.Nos  | Cat. 6 cables for local networks  |
|------------------|----------|---|
|                  |          | Performance 250 MHz<br>Cables with 4 pairs or 2 x 4 twisted pairs, 100 Ω<br>Blue RAL 5015<br>ANSI/TIA colour code<br>Compliant with ISO/IEC 11 801, EN 50173 and ANSI/TIA 568 standards<br>Products conforming to the CPR regulations<br>Euroclass Dca for LSZH cables (except Cat No 0 328 86: Euroclass Cca and Cat No 0 328 79 : Euroclass B2ca), Euroclass Eca for PVC cables |
| 305 <sup>1</sup> | 0 327 54 | <b>U/UTP - 4 pairs</b><br>Length 305 m<br>Supplied in cardboard box. Weight 14 kg   |
| 305 <sup>1</sup> | 0 328 86 | Length 305 m<br>Supplied in cardboard box. Weight 15 kg   |
| 305 <sup>1</sup> | 0 328 79 | Length 500m<br>Supplied on reel. Weight 24 kg   |
| 500 <sup>1</sup> | 0 328 61 | Length 500 m<br>Supplied on reel. Weight 19 kg  |
| 305 <sup>1</sup> | 0 327 55 | Length 305 m<br>Supplied in cardboard box. Weight 13 kg   |
| 305 <sup>1</sup> | 0 328 56 | <b>F/UTP - 4 pairs</b><br>Length 305 m<br>Supplied in reel in box. Weight 19 kg   |
| 500 <sup>1</sup> | 0 327 56 | Length 500 m<br>Supplied on reel. Weight 27 kg  |
| 305 <sup>1</sup> | 0 328 57 | <b>F/UTP - 4 pairs</b><br>Length 305 m<br>Supplied in reel in box. Weight 20 kg   |
| 500 <sup>1</sup> | 0 327 58 | Length 500 m<br>Supplied on reel. Weight 25 kg  |
| 500 <sup>1</sup> | 0 327 76 | <b>F/UTP - 2 x 4 pairs</b><br>Length 500 m<br>Supplied on reel. Weight 51 kg  |
| 500 <sup>1</sup> | 0 327 57 | <b>SF/UTP - 4 pairs</b><br>Length 500 m<br>Supplied on reel. Weight 31 kg   |
| 500 <sup>1</sup> | 0 327 59 | Length 500 m<br>Supplied on reel. Weight 30 kg  |

1: in metre(s)

| Pack | Cat.Nos | Cat. 6 RJ 45 patch cords and user cords  |
|------|---------|--|
|      |         | RJ 45/RJ 45 - straight<br>Compliant with ISO/IEC 11 801, EN 50173 and ANSI/TIA 568 standards                     |
|      |         | <b>Shielded SF/UTP, impedance 100 Ω</b><br>Length 1 m<br>Length 2 m<br>Length 3 m<br>Length 5 m                  |
|      |         | <b>Screened F/UTP, impedance 100 Ω</b><br>Length 0.5 m<br>Length 1 m<br>Length 2 m<br>Length 3 m<br>Length 5 m   |
|      |         | <b>Unshielded U/UTP, impedance 100 Ω</b><br>Length 0.5 m<br>Length 1 m<br>Length 2 m<br>Length 3 m<br>Length 5 m |
|      |         | <b>Unshielded U/UTP impedance 100 Ω</b><br>Length 0.5 m<br>Length 1 m<br>Length 2 m<br>Length 3 m<br>Length 5 m  |

| Pack | Cat.Nos  | Cat. 6 RJ 45 patch cords and user cords - High Density   |
|------|----------|--|
|      |          | RJ 45/RJ 45 - straight<br>Compliant with ISO/IEC 11 801, EN 50173 and ANSI/TIA 568 standards   |
|      |          | <b>Screened F/UTP, impedance 100 Ω</b><br>Length 0.5 m<br>Length 1 m<br>Length 2 m<br>Length 3 m<br>Length 5 m   |
|      |          | <b>Unshielded U/UTP impedance 100 Ω</b><br>Length 0.5 m<br>Length 1 m<br>Length 2 m<br>Length 3 m<br>Length 5 m  |
| 200  | 0 518 90 | <b>Marking kit</b><br>Kit of 200 coloured rings for marking RJ 45 cords<br>4 colors (green/red/yellow/blue). 50 pieces of each color<br>Rings to be clipped onto the patch cords |

# Legrand cabling system, LCS<sup>3</sup> cat. 6

## RJ 45 sockets - Mosaic™



Can be integrated in any support  
 Mechanisms to be equipped with support frames and plates  
 Equipped with connectors with quick toolless connection  
 Take single-core cables from AWG 22 up to AWG 26, and AWG 26 multicore cables  
 T568A and B marking with colour codes  
 Compliant with ISO/IEC 11 801, EN 50173 and ANSI/TIA 568 standards

| Pack | Cat.Nos   | Cat. 6 RJ 45 sockets - Mosaic   | Pack | Cat.Nos  | Cat. 6 RJ 45 sockets - Mosaic (continued)   |
|------|-----------|---|------|----------|---|
| 10   | 0 765 61  | <b>UTP - 1 module</b><br>○ White  | 5    | 0 765 95 | <b>FTP with controlled access - 2 modules</b><br>Supplied with 2 keys for 5 sockets<br>○ White with red shutter   |
| 10   | 0 794 61  | ● Aluminium   | 10   | 0 765 05 | <b>FTP 45° - 2 modules</b><br>○ White   |
| 10   | 0 794 61L | ● Matt Black  | 5    | 0 765 06 | <b>FTP 45° - 2 x RJ 45 - 2 modules</b><br>○ White   |
| 10   | 0 765 81  | ○ White antimicrobial <sup>(1)</sup>  | 1    | 0 765 33 | <b>FTP with retractable cord - 4 modules</b><br>With integrated retractable cord (0.9 m)<br>Automatically winds back in at the press of a button<br>○ White |
| 10   | 0 765 64  | <b>UTP - 2 modules</b><br>○ White   | 1    | 0 794 33 | ● Aluminium   |
| 10   | 0 794 64  | ● Aluminium   | 10   | 0 765 92 | <b>FTP 90° - 2 modules</b><br>Vertical snap-on socket for column module<br>○ White  |
| 10   | 0 791 64L | ● Matt Black  | 10   | 0 794 92 | ● Aluminium   |
| 5    | 0 765 94  | <b>UTP with controlled access - 2 modules</b><br>Supplied with 2 keys for 5 sockets<br>○ White with red shutter   | 10   | 0 765 63 | <b>Shielded STP - 1 module</b><br>○ White   |
| 10   | 0 765 91  | <b>UTP 90° - 2 modules</b><br>Vertical snap-on socket for column module<br>○ White  | 10   | 0 765 83 | ○ White antimicrobial <sup>(1)</sup>  |
| 10   | 0 765 03  | <b>UTP 45° - 2 modules</b><br>○ White   | 10   | 0 765 66 | <b>Shielded STP - 2 modules</b><br>○ White  |
| 5    | 0 765 04  | <b>UTP 45° - 2 x RJ 45 - 2 modules</b><br>○ White   | 5    | 0 765 96 | <b>Shielded STP with controlled access - 2 modules</b><br>Supplied with 2 keys for 5 sockets<br>○ White with red shutter                                    |
| 1    | 0 765 32  | <b>UTP with retractable cord - 4 modules</b><br>With integrated retractable cord (0.9 m)<br>Automatically winds back in at the press of a button<br>○ White | 10   | 0 765 07 | <b>STP 45° - 2 modules</b><br>○ White   |
| 5    | 0 765 44  | <b>UTP 2 x RJ 45 with Soluclip accessory - 4 modules</b><br>For snap-on mounting on DLP trunking with 45 mm cover<br>○ White                                | 10   | 0 765 93 | <b>Shielded STP 90° - 2 modules</b><br>Vertical snap-on socket for column module<br>○ White   |
| 10   | 0 765 62  | <b>FTP - 1 module</b><br>○ White  |      |          |   |
| 10   | 0 794 62  | ● Aluminium   |      |          |   |
| 10   | 0 791 62L | ● Matt Black  |      |          |   |
| 10   | 0 765 82  | ○ White antimicrobial <sup>(1)</sup>  |      |          |   |
| 10   | 0 765 65  | <b>FTP - 2 modules</b><br>○ White   |      |          |   |
| 10   | 0 794 65  | ● Aluminium   |      |          |   |
| 10   | 0 791 65L | ● Matt Black  |      |          |   |
| 10   | 0 765 22  | ○ White with green shutter  |      |          |   |
| 10   | 0 765 23  | ○ White with orange shutter   |      |          |   |
| 5    | 0 765 46  | <b>FTP 2 x RJ 45 with Soluclip accessory - 4 modules</b><br>For snap-on mounting on trunking with 45 mm cover<br>○ White                                    |      |          |   |

1: Contains a silver compound which prevents the growth of bacteria at the surface

# Legrand cabling system, LCS<sup>3</sup> cat. 6

## RJ 45 sockets (Arteor, Soliroc and Plexo) and other connectors



Can be integrated in any support  
 Equipped with connectors with quick toolless connection  
 Take single-core cables from AWG 22 up to AWG 26, and AWG 26 multicore cables  
 T568A and B marking with colour codes  
 Compliant with ISO/IEC 11 801, EN 50173 and ANSI/TIA 568 standards

| Pack | Cat.Nos  | Cat. 6 RJ 45 sockets - Arteor  |
|------|----------|--|
|      |          | Mechanisms supplied with square rocker plates, to be equipped with support frames and plates     |
|      |          | <b>UTP - 1 module</b>  |
| 10   | 5 723 02 | ○ White  |
| 10   | 5 728 02 | ● Magnesium  |
| 10   | 5 700 57 | ● Champagne  |
| 10   | 5 710 57 | ● Soft Alu   |
| 10   | 5 723 54 | ○ White with orange shutter  |
| 10   | 5 728 54 | ● Magnesium with orange shutter  |
| 10   | 5 728 74 | ● Champagne with orange shutter  |
| 10   | 5 728 73 | ● Soft Alu with orange shutter   |
| 10   | 5 723 55 | ○ White with green shutter   |
| 10   | 5 728 55 | ● Magnesium with green shutter   |
| 10   | 5 728 80 | ● Champagne with green shutter   |
| 10   | 5 728 79 | ● Soft Alu with green shutter  |
|      |          | <b>UTP - 2 modules</b>   |
| 10   | 5 723 14 | ○ White - square version   |
| 10   | 5 728 14 | ● Magnesium - square version   |
| 10   | 5 700 59 | ● Champagne - square version   |
| 10   | 5 710 59 | ● Soft Alu - square version  |
|      |          | <b>UTP with controlled access - 2 modules</b>  |
|      |          | Supplied with 2 keys for 5 sockets   |
| 5    | 5 723 53 | ○ White with red shutter   |
| 5    | 5 728 53 | ● Magnesium with red shutter   |
| 5    | 5 728 87 | ● Champagne with red shutter   |
| 5    | 5 728 86 | ● Soft Alu with red shutter  |
|      |          | <b>UTP with retractable cord - 4 modules</b>   |
|      |          | With integrated retractable cord (0.9 m)<br>Automatically winds back in at the press of a button |
| 1    | 5 723 39 | ○ White  |
| 1    | 5 728 39 | ● Magnesium  |
| 1    | 5 728 89 | ● Champagne  |
| 1    | 5 728 88 | ● Soft Alu   |
|      |          | <b>FTP - 1 module</b>  |
| 10   | 5 723 22 | ○ White  |
| 10   | 5 728 22 | ● Magnesium  |
| 10   | 5 728 91 | ● Champagne  |
| 10   | 5 728 90 | ● Soft Alu   |
|      |          | <b>FTP - 2 modules</b>   |
| 10   | 5 723 16 | ○ White  |
| 10   | 5 728 16 | ● Magnesium  |
| 10   | 5 728 93 | ● Champagne  |
| 10   | 5 728 92 | ● Soft Alu   |
|      |          | <b>Shielded STP - 1 module</b>   |
| 10   | 5 723 23 | ○ White  |
| 10   | 5 728 23 | ● Magnesium  |
| 10   | 5 728 95 | ● Champagne  |
| 10   | 5 728 94 | ● Soft Alu   |
|      |          | <b>Shielded STP - 2 modules</b>  |
| 10   | 5 723 17 | ○ White  |
| 10   | 5 728 17 | ● Magnesium  |
| 10   | 5 728 97 | ● Champagne  |
| 10   | 5 728 96 | ● Soft Alu   |

| Pack | Cat.Nos  | Cat. 6 Soliroc RJ 45 socket - IK 10  |
|------|----------|--|
| 1    | 0 778 91 | <b>FTP - 2 modules</b><br>IP 20 - IK 10<br>For at-risk areas or areas without surveillance   |
|      |          | <b>Cat. 6 Plexo RJ 45 sockets - IP 55 closed flap IK 07</b>  |
|      |          | <b>RJ 45 sockets</b><br>Protection against water, dust<br>For industrial sites   |
| 5    | 0 695 69 | ● Grey   |
| 1    | 0 695 61 | FTP socket<br>UTP socket   |
|      |          | <b>Adaptor for RJ 45 socket</b><br>RJ 45 to be ordered separately<br>Guaranteed weatherproof seal (IP 44) with the plug inserted   |
| 1    | 0 695 81 | ● Grey   |
|      |          | <b>Cat. 6 Plexo 66 RJ 45 socket - IP 66 - IK 08</b>  |
|      |          | <b>FTP socket</b><br>9 contacts<br>Guaranteed weatherproof seal (IP 66) with the plug inserted<br>Inclined 90°   |
| 1    | 0 904 67 | ● Grey RAL 7016/T029   |
|      |          | <b>Cat. 6 Keystone RJ 45 socket</b><br>UTP socket with fast connection   |
| 10   | 0 331 81 |  |
|      |          | <b>Surface mounting box - 1 or 2 ports</b><br>For Keystone connectors<br>For surface mounting installations<br>Can be fixed to a table or used in conjunction with mini-trunking |
| 1    | 6 327 79 |  |
|      |          | <b>Cable extenders</b><br>To be used to extend a cable quickly and easily<br>For FTP Cat. 6 cables   |
| 1    | 0 337 48 |  |
| 1    | 0 337 42 | For UTP Cat. 6 cables  |

Audio/video sockets  
 Arteor and Mosaic  
 p. 145-146



# Legrand cabling system, LCS<sup>3</sup> cat. 6

## zone distribution box solution



| Pack | Cat.Nos  | Zone distribution boxes to be equipped   |
|------|----------|--|
| 1    | 0 337 96 | For distributing data in an area equipped with 1 to 24 RJ 45 sockets<br>Centralise connections to ensure flexibility and scalability of the installation<br>For installation in false ceilings or raised access floors<br>The boxes connect to the patching enclosure or floor cabinet<br>Connection to an RJ 45 socket with an RJ 45/ stripped cord or to a Mosaic RJ 45 socket with copper feedthrough with an RJ 45/RJ 45 cord<br>IP 21 - IK 07<br>Compliant with ISO/IEC 11 801, EN 50173 and ANSI/ TIA 568 standards<br>T568A and B marking with colour codes<br>Technical characteristics: polycarbonate cover (PC), polypropylene base (PP), RAL 7035<br>To be equipped directly with RJ 45 High Density connectors |
| 1    | 0 337 97 | 12 ports to be equipped<br>24 ports to be equipped   |

| Pack | Cat.Nos  | Cat. 6 High Density RJ 45 connectors |
|------|----------|--------------------------------------|
| 6    | 0 337 63 | Set of 6 RJ 45 connectors            |
| 6    | 0 337 64 | UTP                                  |
| 6    | 0 337 65 | FTP                                  |
|      |          | STP                                  |

| Pack | Cat.Nos  | Cat. 6 cords - RJ 45/stripped   |
|------|----------|---|
| 1    | 0 517 96 | RJ 45/stripped - straight<br>Plug in and out of the zone distribution boxes and connect to an LCS <sup>3</sup> connector of an RJ 45 socket via the stripped side<br>Cables prepared in factory, "ready for wiring"<br>Compliant with ISO/IEC 11801 Ed. 2.0 (2011), EN 50173-1 and EIA/TIA 568 C2 standards |
| 1    | 0 517 97 | <b>Screened F/UTP, impedance 100 Ω</b><br>Length 8 m  |
| 1    | 0 517 98 | Length 15 m   |
| 1    | 0 517 98 | Length 20 m   |
| 1    | 0 517 57 | <b>Unscreened U/UTP, impedance 100 Ω</b><br>Length 8 m  |
| 1    | 0 517 58 | Length 15 m   |
| 1    | 0 517 59 | Length 20 m   |

| Pack | Cat.Nos          | Cat. 6 cords - RJ 45/RJ 45   |
|------|------------------|--|
|      | LSZH<br>RAL 5015 | For direct connection via RJ 45 male plug to the zone distribution box and to the RJ 45 socket with copper feedthrough to ensure safe connection, plus speed and reliability of connection |
| 1    | 0 515 13         | <b>Screened F/UTP, impedance 100 Ω</b><br>Length 8 m   |
| 1    | 0 515 14         | Length 15 m  |
| 1    | 0 515 15         | Length 20 m  |
| 1    | 0 515 10         | <b>Unscreened U/UTP, impedance 100 Ω</b><br>Length 8 m   |
| 1    | 0 515 11         | Length 15 m  |
| 1    | 0 515 12         | Length 20 m  |

| Pack | Cat.Nos  | Cat. 6 sockets with copper feedthrough |
|------|----------|--|
| 10   | 0 786 22 | <b>Cat. 6 UTP - Mosaic</b>             |
| 10   | 0 786 26 | ○ White<br>● Aluminium                 |
| 10   | 0 786 23 | <b>Cat. 6 FTP - Mosaic</b>             |
| 10   | 0 786 27 | ○ White<br>● Aluminium                 |
| 10   | 5 723 31 | <b>Cat. 6 UTP - Arteor</b>             |
| 10   | 5 728 31 | ○ White<br>● Magnesium                 |
| 10   | 5 729 10 | ● Champagne                            |
| 10   | 5 729 09 | ● Soft Alu                             |
| 10   | 5 723 33 | <b>Cat. 6 FTP - Arteor</b>             |
| 10   | 5 728 33 | ○ White<br>● Magnesium                 |
| 10   | 5 729 12 | ● Champagne                            |
| 10   | 5 729 11 | ● Soft Alu                             |



## Legrand cabling system, LCS<sup>3</sup> cat. 5e

### flat patch panels - equipped

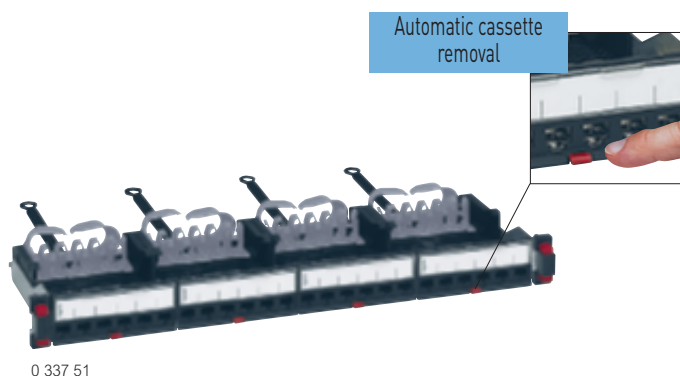

0 337 51

Equipped with new-generation Quick-Fix for automatic (screwless) mounting on enclosure and cabinet uprights  
 Universal mounting on all cabinets or enclosures  
 Panels ensure automatic earthing of each connector  
 Equipped with 4 bundles guides fixed at the rear

| Pack | Cat.Nos  | <b>Cat. 5e patch panels equipped with 24 RJ 45 connectors</b>   |
|------|----------|---|
|      |          | 19" panels - 1U<br>Equipped with 4 cassettes of 6 pre-fitted Cat. 5e LCS <sup>3</sup> RJ 45 connectors<br>Automatic cassette removal by simple pressure<br>Each connector can be removed individually<br>T568A and B marking with colour codes<br>Equipped with rear cable guide to hold cables during maintenance<br>Supplied with coloured labels<br>Compliant with ISO/IEC 11 801, EN 50173 and ANSI/TIA 568 standards |
|      |          | <b>Flat panels</b><br>24 RJ 45 connectors - 1U - PoE++  |
| 1    | 0 337 50 | UTP   |
| 1    | 0 337 51 | FTP   |

## Legrand cabling system, LCS<sup>3</sup> cat. 5e

### flat patch panels, to be equipped

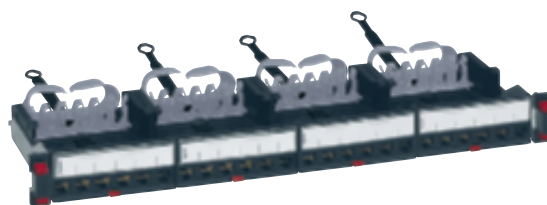

0 337 90



0 337 98

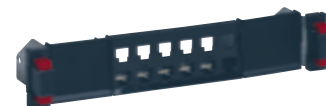

0 337 99

Universal mounting on all cabinets or enclosures  
 Panels ensure automatic earthing of each connector

| Pack | Cat.Nos  | <b>19" flat patch panels - to be equipped</b>  |
|------|----------|--|
|      |          | 19" panels - 1U<br>Equipped with rear cable guide to hold cables during maintenance<br>Automatic cassette removal by simple pressure<br>Each connector can be removed individually                   |
| 1    | 0 337 90 | <b>Flat panel with empty cassettes to be equipped with connectors</b><br>Equipped with 4 automatically removable cassettes, takes up to 24 Cat. 5e to Cat. 8 RJ 45 connectors                        |
| 1    | 0 337 91 | <b>Empty flat panel to be equipped with cassettes</b><br>Takes a maximum of 4 automatically removable cassettes:<br>- copper to be equipped with Cat. 5e to Cat. 8 RJ 45 connectors<br>- fiber optic |
| 1    | 0 337 93 | <b>High Density flat panel with empty cassettes to be equipped with connectors</b><br>Equipped with 4 High Density cassettes, takes up to 48 Cat. 5e to Cat. 6A RJ 45 connectors                     |
|      |          | <b>10" flat patch panels - to be equipped</b>  |
| 1    | 0 337 98 | 10" panels - 1U<br>Takes up to 6 Cat. 5e to Cat. 8 RJ 45 connectors  |
| 1    | 0 337 99 | Takes up to 12 Cat. 5e to Cat. 6A RJ 45 connectors   |

## Legrand cabling system, LCS<sup>3</sup> cat. 5e angled patch panels to be equipped, connectors



0 337 92



0 337 94



0 337 53



Equipped with new-generation Quick-Fix for automatic (screwless) mounting on enclosure and cabinet uprights  
Universal mounting on all cabinets or enclosures  
Panels ensure automatic earthing of each connector  
Equipped with 4 concentric strand guides fixed at the rear

| Pack | Cat.Nos  | Angled patch panels - to be equipped  |
|------|----------|---|
| 1    | 0 337 92 | 19" panels - 1U<br><b>Angled patch panel to be equipped with connectors</b><br>Takes up to 24 Cat. 5e to Cat. 8 RJ 45 connectors  |
| 1    | 0 337 94 | <b>High Density angled panel to be equipped with connectors</b><br>Takes up to 48 Cat. 5e to Cat. 6A RJ 45 connectors   |
| 6    | 0 337 53 | <b>Cat. 5e High Density RJ 45 connectors</b><br>Quick-connect connection (no tools required)<br>T568A and B marking with colour codes<br>Compliant with ISO/IEC 11 801, EN 50173 and ANSI/TIA 568 standards<br>To be installed in cassettes for flat panels or directly in an angled panel or a zone distribution box to be equipped<br>Set of 6 RJ 45 connectors |
| 6    | 0 337 54 | UTP<br>FTP  |

## Legrand cabling system, LCS<sup>3</sup> cat. 5e accessories



0 337 56



0 337 59



0 337 55



0 337 66



0 337 57



0 337 58

| Pack | Cat.Nos  | Common accessories for flat and angled panels   |
|------|----------|---|
| 10   | 0 337 56 | <b>Port blanking modules</b><br>Separable blanking plate<br>For covering 1 to 6 ports or 1 to 12 ports individually (High Density solutions)  |
| 1    | 0 337 59 | <b>Cord management</b><br>2 cable guides to be clipped onto new-generation Quick-Fix<br>Provide side cord management<br>Label-holder for identification   |
| 1    | 0 337 55 | <b>Specific accessories for flat panels</b><br><b>Cassette for flat panels to be equipped</b><br>Removable empty cassette to be equipped with connectors, takes 6 Cat. 5e to Cat. 8 connectors<br>Can be removed by simple pressing on the cassette, for ease of installation and maintenance<br>For equipping flat panels  |
| 1    | 0 337 66 | <b>Cassette with shutters for flat panels to be equipped</b><br>Removable empty cassette to be equipped with connectors, takes 6 Cat. 5e to Cat. 8 connectors<br>Can be removed by simple pressing on the cassette, for ease of installation and maintenance<br>Equipped with 6 individual shutters to protect RJ 45 connectors contacts<br>For equipping flat panels |
| 1    | 0 337 95 | <b>High Density cassette for flat panels to be equipped</b><br>Removable empty cassette to be equipped with connectors, takes 12 Cat. 5e to Cat. 6A connectors<br>Can be removed by simple pressing on the cassette, for ease of installation and maintenance<br>For equipping flat panels  |
| 1    | 0 337 57 | <b>Blanking cassette</b><br>To be used to fill gaps in the panel  |
| 1    | 0 337 58 | <b>Specific accessory for angled panels</b><br><b>Cover</b><br>Optimises air flow management in the enclosure   |

# Legrand cabling system, LCS<sup>3</sup> cat. 5e

## cables and cords

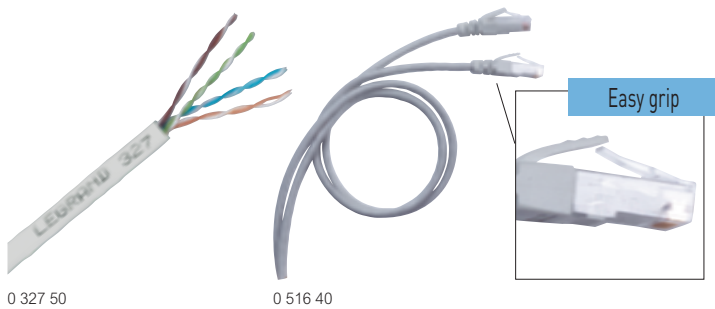

| Pack             | Cat.Nos          | Cat. 5e cables for local networks   |
|------------------|------------------|---|
|                  |                  | Cable with 4 twisted pairs, 100 Ω<br>LSZH sheath: zero halogen<br>Grey RAL 7035<br>ANSI/TIA colour code<br>Compliant with ISO/IEC 11 801, EN 50173, ANSI/TIA 568 standards<br>Products conforming to the CPR regulations<br>Euroclass Dca for LSZH cables, Euroclass Eca for PVC cables |
|                  |                  | <b>U/UTP - 4 pairs</b><br>Length 305 m<br>Supplied in cardboard box. Weight 9 kg  |
| 305 <sup>1</sup> | LSZH<br>0 327 50 |   |
| 500 <sup>1</sup> | 0 328 53         | Supplied on reel. Weight 15 kg  |
| 305 <sup>1</sup> | PVC<br>0 327 51  | Length 305 m<br>Supplied in cardboard box. Weight 9 kg  |
| 305 <sup>1</sup> | 0 327 52         | <b>F/UTP - 4 pairs</b><br>Length 305 m<br>Supplied in cardboard box. Weight 12 kg   |
| 500 <sup>1</sup> | 0 328 50         | Length 500 m<br>Supplied on reel. Weight 21 kg  |
| 305 <sup>1</sup> | 0 327 53         | Length 305 m<br>Supplied in cardboard box. Weight 11 kg   |

| Pack | Cat.Nos         | Cat. 5e RJ 45 patch cords and user cords   |
|------|-----------------|--|
|      |                 | RJ 45/RJ 45 - straight<br>Compliant with ISO/IEC 11 801, EN 50173, ANSI/TIA 568 standards<br>Grey RAL 7035   |
|      |                 | <b>Unscreened U/UTP, impedance 100 Ω</b><br>Length 0.5 m<br>Length 1 m<br>Length 2 m<br>Length 3 m<br>Length 5 m   |
| 1    | PVC<br>0 518 17 |  |
| 1    | 0 516 36        | Length 1 m   |
| 1    | 0 516 37        | Length 2 m   |
| 1    | 0 516 38        | Length 3 m   |
| 1    | 0 516 39        | Length 5 m   |
|      |                 | <b>Screened F/UTP, impedance 100 Ω</b><br>Length 0.5 m<br>Length 1 m<br>Length 2 m<br>Length 3 m<br>Length 5 m   |
| 1    | 0 518 14        | Length 0.5 m   |
| 1    | 0 516 40        | Length 1 m   |
| 1    | 0 516 41        | Length 2 m   |
| 1    | 0 516 42        | Length 3 m   |
| 1    | 0 516 43        | Length 5 m   |
|      |                 | <b>Marking kit</b><br>Kit of 200 coloured rings for marking RJ 45 cords<br>4 colors (green/red/yellow/blue). 50 pieces of each color<br>Rings to be clipped onto the patch cords<br>1: in metre(s) |
| 200  | 0 518 90        |  |

# Legrand cabling system, LCS<sup>3</sup> cat. 5e

## RJ 45 sockets (Arteor, Soliroc and Plexo) and other connectors



Can be integrated in any support  
 Equipped with connectors with quick connection  
 Take single-core cables from AWG 22 up to AWG 26, and AWG 26 multicore cables  
 T568A and B marking with colour codes  
 Compliant with ISO/IEC 11 801, EN 50173 and ANSI/TIA 568 standards

| Pack | Cat.Nos  | Cat. 5e RJ 45 sockets - Mosaic   |
|------|----------|--|
|      |          | Mechanisms to be equipped with support frames and plates   |
| 10   | 0 765 51 | <b>UTP - 1 module</b><br>○ White<br>● Aluminium  |
| 10   | 0 794 51 |  |
| 10   | 0 765 54 | <b>UTP - 2 modules</b><br>○ White<br>● Aluminium   |
| 10   | 0 794 54 |  |
| 5    | 0 765 97 | <b>UTP with controlled access - 2 modules</b><br>Supplied with 2 keys for 5 sockets<br>○ White with red shutter                                  |
| 5    | 0 765 41 | <b>UTP - 2 x RJ 45 with Soluclip accessory - 3 modules</b><br>For snap-on mounting on DLP trunking with 45 mm cover<br>○ White                   |
|      |          | <b>UTP with retractable cord - 4 modules</b><br>With integrated retractable cord (0.9 m)<br>Automatically winds back in at the press of a button |
| 1    | 0 765 30 | ○ White  |
| 10   | 0 765 01 | <b>UTP 45° - 2 modules</b><br>○ White  |
| 5    | 0 765 02 | <b>UTP 45° - 2 x RJ 45 - 2 modules</b><br>○ White  |
| 10   | 0 765 52 | <b>FTP - 1 module</b><br>○ White<br>● Aluminium  |
| 10   | 0 794 52 |  |
| 10   | 0 765 55 | <b>FTP - 2 modules</b><br>○ White<br>● Aluminium   |
| 10   | 0 794 55 |  |
| 5    | 0 765 98 | <b>FTP with controlled access - 2 modules</b><br>Supplied with 2 keys for 5 sockets<br>○ White with red shutter                                  |
| 5    | 0 765 42 | <b>FTP - 2 x RJ 45 with Soluclip accessory - 3 modules</b><br>For snap-on mounting on Mosaic trunking with 45 mm cover<br>○ White                |

| Pack | Cat.Nos  | Cat. 5e RJ 45 sockets - Arteor   |
|------|----------|--|
|      |          | Mechanisms supplied with square rocker plates, to be equipped with support frames and plates   |
| 10   | 5 723 03 | <b>UTP - 1 module</b><br>○ White<br>● Aluminium  |
| 10   | 5 728 03 |  |
| 10   | 5 700 58 | ● Champagne<br>● Soft Alu  |
| 10   | 5 710 58 |  |
| 10   | 5 723 15 | <b>UTP - 2 modules</b><br>○ White<br>● Aluminium<br>● Champagne<br>● Soft Alu  |
| 10   | 5 728 15 |  |
| 10   | 5 728 99 |  |
| 10   | 5 728 98 |  |
| 10   | 5 723 04 | <b>FTP - 1 module</b><br>○ White<br>● Aluminium<br>● Champagne<br>● Soft Alu   |
| 10   | 5 728 04 |  |
| 10   | 5 729 08 |  |
| 10   | 5 729 07 |  |
|      |          | <b>Cat. 5e Plexo RJ 45 sockets - IP 55 closed flap IK 07</b>   |
|      |          | <b>RJ 45 sockets</b><br>Protection against water, dust<br>For industrial sites<br>● Grey   |
| 1    | 0 695 57 | <br>FTP socket   |
| 1    | 0 695 56 |  |
| 1    | 0 695 81 | <b>Adaptor for RJ 45 socket</b><br>RJ 45 to be ordered separately.<br>Guaranteed weatherproof seal (IP 44)<br>with plug inserted<br>● Grey                                       |
| 10   | 0 331 80 | <b>Cat. 5e Keystone RJ 45 socket</b><br>UTP with quick toolless connection   |
| 1    | 6 327 79 | <b>Surface mounting box - 1 or 2 ports</b><br>For Keystone connectors<br>For surface mounting installations<br>Can be fixed to a table or used in conjunction with mini-trunking |



# Legrand cabling system, LCS<sup>3</sup> Cat. 5e

## zone distribution box solution

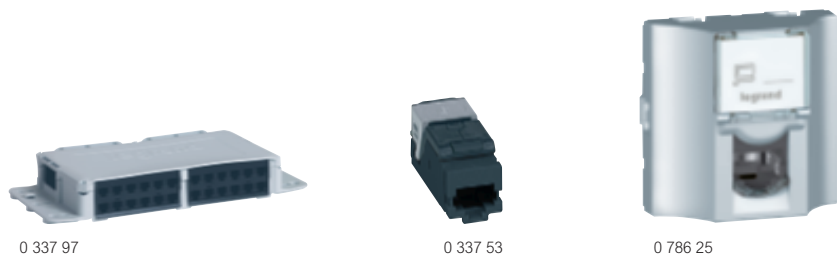

| Pack | Cat.Nos  | Zone distribution boxes to be equipped  |
|------|----------|---|
|      |          | <p>For distributing data in an area equipped with 1 to 24 RJ 45 sockets</p> <p>Centralise connections to ensure flexibility and scalability of the installation</p> <p>For installation in false ceilings or raised access floors</p> <p>The boxes connect to the patching enclosure or floor cabinet</p> <p>Connection to an RJ 45 socket with an RJ 45/ stripped cord or to a Mosaic RJ 45 socket with copper feedthrough with an RJ 45/RJ 45 cord</p> <p>IP 21 - IK 07</p> <p>Compliant with ISO/IEC 11 801, EN 50173 and ANSI/ TIA 568 standards</p> <p>T568A and B marking with colour codes</p> <p>Technical characteristics: polycarbonate cover (PC), polypropylene base (PP), RAL 7035</p> <p>To be equipped directly with RJ 45 High Density connectors</p> |
| 1    | 0 337 96 | 12 ports to be equipped   |
| 1    | 0 337 97 | 24 ports to be equipped   |

| Pack | Cat.Nos  | Cat. 5e High Density RJ 45 connectors |
|------|----------|---------------------------------------|
| 6    | 0 337 53 | Set of 6 RJ 45 connectors UTP         |
| 6    | 0 337 54 | Set of 6 RJ 45 connectors FTP         |

| Pack | Cat.Nos  | Cat. 5e cords - RJ 45/RJ 45   |
|------|----------|---|
|      |          | <p>For direct connection via RJ 45 male plug to the zone distribution box and to the RJ 45 socket with copper feedthrough to ensure safe connection, plus speed and reliability of connection</p> |
|      |          | <p><b>Screened F/UTP, impedance 100 Ω</b></p> <p>Length 8 m</p> <p>Length 15 m</p> <p>Length 20 m</p>   |
| 1    | 0 515 03 |   |
| 1    | 0 515 04 |   |
| 1    | 0 515 05 |   |
|      |          | <p><b>Unscreened U/UTP, impedance 100 Ω</b></p> <p>Length 8 m</p> <p>Length 15 m</p> <p>Length 20 m</p>   |
| 1    | 0 515 00 |   |
| 1    | 0 515 01 |   |
| 1    | 0 515 02 |   |

| Pack | Cat.Nos  | Cat. 5e sockets with copper feedthrough   |
|------|----------|---|
|      |          | <p><b>Cat. 5e UTP - Mosaic</b></p> <p>○ White</p> <p>● Aluminium</p>                                      |
| 10   | 0 786 20 |   |
| 10   | 0 786 24 |   |
|      |          | <p><b>Cat. 5e FTP - Mosaic</b></p> <p>○ White</p> <p>● Aluminium</p>                                      |
| 10   | 0 786 21 |   |
| 10   | 0 786 25 |   |
|      |          | <p><b>Cat. 5e UTP - Arteor</b></p> <p>○ White</p> <p>● Magnesium</p> <p>● Champagne</p> <p>● Soft Alu</p> |
| 10   | 5 723 30 |   |
| 10   | 5 728 30 |   |
| 10   | 5 729 18 |   |
| 10   | 5 729 17 |   |
|      |          | <p><b>Cat. 5e FTP - Arteor</b></p> <p>○ White</p> <p>● Magnesium</p> <p>● Champagne</p> <p>● Soft Alu</p> |
| 10   | 5 723 32 |   |
| 10   | 5 728 32 |   |
| 10   | 5 729 20 |   |
| 10   | 5 729 19 |   |

# Legrand cabling system, LCS<sup>3</sup> Series HDJ

flat panels, cassettes and connectors

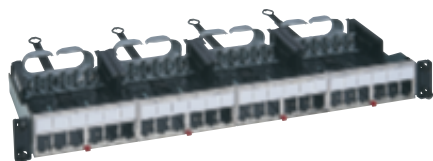

0 336 83

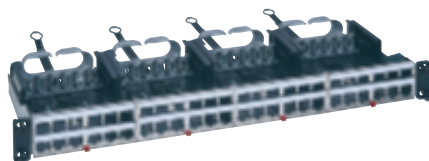

0 336 84

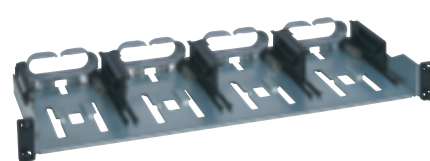

0 336 82

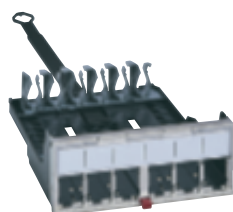

0 336 80



0 336 81



HDJ6A-44



HDJ6-44

Standard fixing  
 Universal mounting on all cabinets or enclosures  
 Panels ensure automatic earthing of each connector  
 Equipped with rear cable guides to hold cables during maintenance

| Pack   | Cat.Nos  | Flat patch panels - to be equipped  |
|--|----------|---|
| 1  | 0 336 83 | 19" panels - 1U<br>Equipped with 4 automatically removable cassettes, takes up to 24 Cat. 5e to Cat. 6A RJ 45 HD Jack connectors  |
| 1  | 0 336 84 | Equipped with 4 automatically removable HD cassettes, takes up to 48 Cat. 5e to Cat. 6A RJ 45 HD Jack connectors  |
| <b>Empty flat patch panels - to be equipped</b>  |          |   |
| 1  | 0 336 82 | <b>19" panel - 1 U - standard fixation</b><br>Takes a maximum of 4 automatically removable cassettes to be equipped with up to 24 Cat. 5e to Cat. 6A RJ 45 HD Jack connectors             |
| 1  | 0 337 91 | <b>19" panel - 1 U - automatic fixation (Soluclip)</b><br>Takes a maximum of 4 automatically removable cassettes to be equipped with up to 24 Cat. 5e to Cat. 6A RJ 45 HD Jack connectors |
| <b>Cassettes for flat panels to be equipped</b>  |          |   |
| Can be removed by simple pressing on the cassette, for ease of installation and maintenance<br>For equipping flat panels |          |   |
| 1  | 0 336 80 | Removable empty cassette to be equipped with connectors, takes 6 Cat. 5e to Cat. 6A RJ 45 HD Jack connectors  |
| 1  | 0 336 81 | Removable empty cassette to be equipped with connectors, takes 12 Cat. 5e to Cat. 6A RJ 45 HD Jack connectors   |
| <b>Blanking cassette</b>   |          |   |
| 1  | 0 336 85 | To be used to fill gaps in the panel  |

| Pack   | Cat.Nos    | RJ 45 HD Jack connectors   |
|--|------------|--|
|  |            | Quick-connect connection (no tools required)<br>T568A and B marking with colour codes<br>Compliant with following standards: ISO/IEC 11 801 ; EN 50173 ; ANSI/TIA-568-C.2 ; UL 1863 (and UL 2043 for Cat.Nos HDJS) ; IEEE 802.3af/802.3at/802.3bt Type 1 to Type 4 ; FCC part 68 subpart F ; IEC-603-7<br>Intertek ETL Verified component<br>To be installed in cassettes Cat.Nos 0 336 80 and 0 336 81 for flat panels<br>Set of 20 connectors except for Cat.Nos HDJS625 and HDJS6A25 (set of 25 connectors) |
|  |            | <b>Cat. 6A RJ 45 HD Jack connectors</b>  |
| 20   | HDJ6A-00   | UTP - Black  |
| 20   | HDJ6A-36   | UTP - Blue   |
| 20   | HDJ6A-44   | UTP - Yellow   |
| 25   | HDJS6A25   | STP  |
|  |            | <b>Cat. 6 RJ 45 HD Jack connectors</b>   |
| 20   | HDJ6-00    | UTP - Black  |
| 20   | HDJ6-36    | UTP - Blue   |
| 20   | HDJ6-44    | UTP - Yellow   |
| 20   | HDJ6-88    | UTP - White  |
| 25   | HDJS625    | STP  |
|  |            | <b>Cat. 5e RJ 45 HD Jack connector</b>   |
| 20   | HDJ5E-78   | UTP - Dark gray  |
| <b>Blank module for RJ 45 HD Jack connectors</b> |            |  |
| 10   | HDJBL10-00 | HDJ - Black  |

## Legrand cabling system, LCS<sup>3</sup>

### PoE WAP and switches



0 335 23



0 334 92



4 131 11

| Pack | Cat.Nos  | PoE Wi-Fi Access Point  |
|------|----------|---|
| 1    | 0 335 23 | Plug & play product to be installed on any RJ 45 socket connected to a Power over Ethernet switch<br>Self-powered with PoE<br>Easy configuration with a smartphone or computer (browser based)<br>Possibility to choose Wi-Fi signal strength (only in room or beyond)<br>WPS (Wi-Fi Protected Setup) and On/Off functions<br>White |
|      |          | <b>PoE Ethernet switches</b>  |
|      |          | Ethernet switches with PoE and PoE+ EndSpan injector (standard IEEE 802.3af and 802.3at)<br>For supplying power to the Ethernet ports of devices (Wi-Fi access point, IP camera, etc)<br>Supplied with power supply   |
|      |          | <b>19" switches</b>   |
| 1    | 0 334 90 | Ethernet switch with 10 RJ 45 ports (8 PoE+ outputs)<br>Gigabit - Manageable  |
| 1    | 0 334 92 | Ethernet switch with 26 RJ 45 ports (24 PoE+ outputs)<br>Gigabit - Manageable   |
|      |          | <b>Tablet switch - 6 ports</b>  |
| 1    | 0 334 93 | Ethernet switch with 6 ports including:<br>- 1 Gigabit RJ 45 and 1 fiber optic SFP uplinks<br>- 4 Gigabit PoE+ RJ 45 outputs<br>Non manageable<br>Whole device power: 65W<br>Max power: 30W per port  |
|      |          | <b>Tablet switches - 5 ports</b>  |
|      |          | Ethernet switches with 5 ports including:<br>- 1 RJ 45 uplink<br>- 4 Gigabit PoE+ RJ 45 outputs<br>Non manageable<br>Whole device power : 58W   |
| 1    | 4 131 11 | EU power supply cord  |
| 1    | 4 131 13 | BS power supply cord  |

## Legrand cabling system

### doublers and weatherproof adaptors

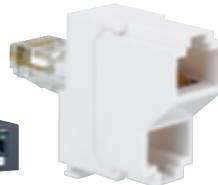

0 327 47



0 539 49

| Pack | Cat.Nos  | Mobile doublers   |
|------|----------|---|
| 10   | 0 327 83 | Clip into RJ 45 sockets to double up applications<br>TV/computer network or telephone doubler   |
| 10   | 0 327 47 | Telephone/telephone doubler   |
| 10   | 0 327 45 | Computer network/telephone doubler  |
| 10   | 0 327 46 | L1/L2 telephone doubler   |
| 10   | 0 327 48 | Computer network/computer network doubler   |
|      |          | <b>Weatherproof adaptors</b>  |
|      |          | <b>Plexo adaptors</b>   |
|      |          | IP 55 - IK 07<br>Take 2-module Mosaic mechanisms without a support (RJ 45 socket, telephone socket, coded keypad, etc) except special surface mounting type |
| 10   | 0 695 80 | Adaptor with smoked flap  |
| 1    | 0 695 79 | Adaptor with smoked flap lockable by means of a special tool  |
| 1    | 0 695 81 | Adaptor for RJ socket ensuring IP 44 sealing of the cable when already connected  |
| 1    | 0 919 45 | Locking tool (used for changing vandal-proof screws)  |
|      |          | <b>Soliroc adaptors</b>   |
|      |          | Used for adapting all functions<br>2-module Mosaic mechanisms (except special surface mounting type)<br>IK 10 - IP 55                                       |
| 1    | 0 778 80 | Adaptor with flap   |
| 1    | 0 778 81 | Adaptor without flap  |
|      |          | <b>Hypra adaptor</b>  |
| 5    | 0 539 49 | IP 55 adaptor base  |

## Legrand cabling system, LCS<sup>3</sup>

sockets, panel and cables for telephone application



0 787 31



0 335 79

| Pack | Cat.Nos         |          | Telephone sockets   |
|------|-----------------|----------|---|
|      |                 |          | <b>RJ 11 and RJ 12 sockets</b><br>Equipped with a modular Jack connector with 1/4-turn terminal for fast connection<br>Tap-off possible |
| 10   | Mosaic   Arteor |          |   |
|      | 0 787 30        | 5 723 00 | ○ White - RJ 11, 4 contacts, 1 module   |
| 10   | 0 792 31        |          | ● Aluminium - RJ 11, 4 contacts, 1 module   |
| 10   |                 | 5 728 00 | ● Magnesium - RJ 11, 4 contacts, 1 module   |
| 10   | 0 787 31        | 5 723 13 | ○ White - RJ 11 - 4 contacts, 2 modules   |
| 10   |                 | 5 728 13 | ● Magnesium - RJ 11 - 4 contacts, 2 modules   |
| 10   | 0 787 32        | 5 723 12 | ○ White - RJ 12 - 6 contacts, 2 modules   |
| 10   |                 | 5 728 12 | ● Magnesium - RJ 12 - 6 contacts, 2 modules-  |
|      |                 |          | <b>ISDN socket</b><br>Self-stripping 1/4 turn terminals for fast connection. Tap-off possible   |
| 10   | 0 787 34        |          | ○ White - 8 contacts, 2.5 mm <sup>2</sup> earth terminal  |
|      |                 |          | <b>Single master - 2 modules</b><br>With IDC connection<br>Conform to British Telecom   |
| 10   |                 | 5 723 10 | ○ White   |
| 10   |                 | 5 728 10 | ● Magnesium   |
|      |                 |          | <b>Single secondary - 1 module</b><br>With IDC connection<br>Conform to British Telecom   |
| 5    |                 | 5 723 01 | ○ White   |
| 5    |                 | 5 728 01 | ● Magnesium   |

|   |          |   |
|---|----------|---|
| 1 | 0 335 79 | <b>Telephone patch panel - 50 ports 110 connect</b><br>19" panel - 1U |
|---|----------|---|

| Cables for telephone networks |                  |  |
|-------------------------------|------------------|--|
|                               |                  | Cables - Cat. 3. Colour: white<br>TIA/EIA colour code        |
| 1                             | LSZH<br>0 328 91 | <b>U/UTP - 50 pairs</b><br>Length 500 m<br>Supplied on reel  |
| 1                             | 0 328 88         | <b>U/UTP - 100 pairs</b><br>Length 500 m<br>Supplied on reel |

## Legrand cabling system, LCS<sup>3</sup>

accessories



0 517 09



0 327 60

| Pack | Cat.Nos  | 110 tool   |
|------|----------|--|
| 1    | 0 332 60 | 110 tool   |
| 5    | 0 332 61 | Replacement blade  |
|      |          | <b>Crimping tool for RJ 45 plugs</b><br>For crimping RJ plugs with 4/6/8/9 contacts<br>Ratchet control of crimping mechanism<br>Possibility to cut and strip cables<br>Tool with 3 crimping points<br>High resistance steel material   |
| 1    | 0 517 09 |  |
|      |          | <b>RJ plugs for round cables - for crimping</b><br>Gold-coated contacts, 1.2 µm  |
| 50   | 0 517 01 | <b>RJ 11</b><br>4 contacts   |
| 50   | 0 517 02 | <b>RJ 12</b><br>6 contacts   |
| 50   | 0 517 03 | <b>RJ 45 Cat. 5e</b><br>8 contacts   |
| 50   | 0 517 04 | 9 contacts   |
| 50   | 0 517 10 | <b>RJ 45 Cat. 6</b><br>8 contacts  |
| 50   | 0 517 11 | 9 contacts   |
| 50   | 0 517 06 | <b>RJ 45 sleeves</b><br>Black  |
| 50   | 0 517 07 | White  |
|      |          | <b>Cable protection accessories</b><br>Plastic material<br>IP 66/67 guaranteed when paired with Cat.Nos 0 533 02<br>IP 55 when not connected for base with shutter<br>Protection for shielded or unshielded RJ 45 cords to create a Cat. 5 connection<br>Compliant with IEC 60603-7 series and IEC 61076-3-106 (version 5) standards<br>Compatible with commercially-available products conforming to the aforementioned standards |
| 3    | 0 533 00 | <b>Plug</b><br>Integrated cable gland with sealing ring and clamping blades<br>Toolless assembly<br>Can protect RJ 45 cords  |
| 3    | 0 533 01 | <b>Flush-mounting base</b><br>Locking base<br>Supplied with Cat. 5e female/female RJ 45 coupler  |
| 3    | 0 533 02 | <b>Kit</b><br>Flush-mounting base + plug   |
| 3    | 0 533 03 | <b>Protective flap</b><br>Fits on base Cat.No 0 533 01   |
|      |          | <b>Stripping tools</b><br>Slit the sheath and release the conductors by rotation<br>For twisted pair cables<br>Don't damage the conductors   |
| 1    | 0 332 62 | <b>Stripper</b><br>For twisted pair  |
| 1    | 0 327 60 | <b>Cutting pliers</b><br>Cut wires cleanly without damaging the copper   |



# Legrand cabling system, LCS<sup>3</sup> fiber optic

## cables

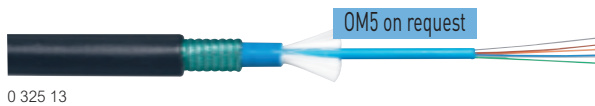

Selection chart p. 106-107

Colour code: FOTAG  
 Compliant with EN 50173-2 and ISO IEC 11801 standards  
 Packed on a 2000 m reel except for tight-buffer OM4  
 Tight-buffer: "easy strip"  
 Other configurations on request

| Pack              | Cat.Nos    |                     | <b>Single-mode OS2 fiber optic cables (9/125 μm) - (OS1 compatible)</b><br>For 9/125 μm single-mode installations, OS2 type<br><b>Indoor/Outdoor</b><br>Yellow LSZH sheath<br>Glass strands<br>4 fibers - Euroclass Dca<br>6 fibers - Euroclass Dca<br>8 fibers - Euroclass Dca<br>12 fibers - Euroclass Dca<br>12 fibers - Euroclass Cca<br>24 fibers - Euroclass Dca<br>24 fibers - Euroclass Cca<br><b>Outdoor</b><br>Black PE sheath<br>Glass strands for rodent-proofing, reinforced with corrugated steel<br>4 fibers<br>6 fibers<br>8 fibers<br>12 fibers<br>24 fibers |
|-------------------|------------|---------------------|---|
|                   | Loose tube | Tight-buffer 900 μm |   |
| 2000 <sup>1</sup> | 0 325 02   | 0 325 50            |   |
| 2000 <sup>1</sup> | 0 325 12   |                     |   |
| 2000 <sup>1</sup> | 0 325 03   |                     |   |
| 2000 <sup>1</sup> | 0 325 14   |                     |   |
| 2000 <sup>1</sup> | 0 325 26   |                     |   |
| 2000 <sup>1</sup> | 0 325 51   |                     |   |
| 1000 <sup>1</sup> | 0 325 18   |                     |   |
| 2000 <sup>1</sup> | 0 325 23   |                     |   |
| 2000 <sup>1</sup> | 0 325 13   |                     |   |
| 2000 <sup>1</sup> | 0 325 24   |                     |   |
| 2000 <sup>1</sup> | 0 325 15   |                     |   |
| 2000 <sup>1</sup> | 0 325 25   |                     |   |

| Pack              | Cat.Nos    |                     | <b>Multimode OM3 fiber optic cables (50/125 μm)</b><br>For 50/125 μm multimode installations, OM3 type<br>Suitable for 10 Gb Ethernet networks<br>Bend insensitive<br><b>Indoor/Outdoor</b><br>Aqua LSZH sheath<br>Glass strands<br>Euroclass Dca<br>4 fibers<br>6 fibers<br>8 fibers<br>12 fibers<br>24 fibers<br><b>Outdoor</b><br>Black PE sheath<br>Glass strands for rodent-proofing, reinforced with corrugated steel<br>8 fibers<br>12 fibers<br>24 fibers |
|-------------------|------------|---------------------|---|
|                   | Loose tube | Tight-buffer 900 μm |   |
| 2000 <sup>1</sup> | 0 325 37   | 0 325 10            |   |
| 2000 <sup>1</sup> | 0 325 38   |                     |   |
| 2000 <sup>1</sup> | 0 325 39   |                     |   |
| 2000 <sup>1</sup> | 0 325 53   |                     |   |
| 2000 <sup>1</sup> | 0 325 52   |                     |   |
| 2000 <sup>1</sup> | 0 325 40   |                     |   |
| 2000 <sup>1</sup> | 0 325 41   |                     |   |
| 2000 <sup>1</sup> | 0 325 42   |                     |   |

1: in metre(s)

| Pack              | Cat.Nos    |                     | <b>Multimode OM4 fiber optic cables (50/125 μm)</b><br>For 50/125 μm multimode installations, OM4 type<br>Suitable for 10 Gb Ethernet networks<br>Bend insensitive<br><b>Indoor/Outdoor</b><br>Aqua LSZH sheath<br>Glass strands<br>4 fibers - Euroclass Dca<br>6 fibers - Euroclass Dca - 500 m drum<br>6 fibers - Euroclass Dca - 1000 m drum<br>8 fibers - Euroclass Dca<br>12 fibers - Euroclass Dca<br>12 fibers - Euroclass Cca<br>12 fibers - Euroclass Dca - 1000 m drum<br>24 fibers - Euroclass Dca - 1000 m drum<br>24 fibers - Euroclass Cca - 1000 m drum<br><b>Outdoor</b><br>Black PE sheath<br>Glass strands for rodent-proofing, reinforced with corrugated steel<br>4 fibers<br>8 fibers<br>12 fibers |
|-------------------|------------|---------------------|---|
|                   | Loose tube | Tight-buffer 900 μm |   |
| 2000 <sup>1</sup> | 0 325 43   | 0 326 65            |   |
| 500 <sup>1</sup>  |            |                     |   |
| 1000 <sup>1</sup> |            | 0 326 66            |   |
| 2000 <sup>1</sup> | 0 325 44   |                     |   |
| 2000 <sup>1</sup> | 0 325 45   |                     |   |
| 2000 <sup>1</sup> | 0 325 49   |                     |   |
| 1000 <sup>1</sup> |            | 0 326 67            |   |
| 1000 <sup>1</sup> |            | 0 326 68            |   |
| 1000 <sup>1</sup> | 0 325 19   |                     |   |
| 2000 <sup>1</sup> | 0 325 46   |                     |   |
| 2000 <sup>1</sup> | 0 325 47   |                     |   |
| 2000 <sup>1</sup> | 0 325 48   |                     |   |

## Legrand cabling system, LCS<sup>3</sup> fiber optic preterminated links

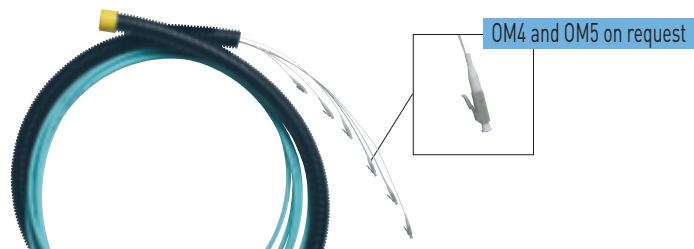

1 320 41

Selection chart p. 108-109

Supplied with pulling element. In coil up to 50 m, on a small drum between 51 m and 150 m, on a large drum over 151 m and up to 200 m  
Connection in fiber optic drawers. OM3 aqua LSZH sheaths. Supplied with test reports

Possible to obtain customised preterminated links: cable type, structure, length, connector type, etc

### Core™ SC/SC tight-buffer OM3 links

| Pack                                 | Cat.Nos  | Description  |
|--------------------------------------|----------|--------------|
| <b>6 SC simplex - 6 SC simplex</b>   |          |              |
| 1                                    | 1 320 01 | Length 10 m  |
| 1                                    | 1 320 02 | Length 20 m  |
| 1                                    | 1 320 03 | Length 30 m  |
| 1                                    | 1 320 04 | Length 40 m  |
| 1                                    | 1 320 05 | Length 50 m  |
| 1                                    | 1 320 06 | Length 60 m  |
| 1                                    | 1 320 07 | Length 70 m  |
| 1                                    | 1 320 08 | Length 80 m  |
| 1                                    | 1 320 09 | Length 90 m  |
| 1                                    | 1 320 10 | Length 100 m |
| 1                                    | 1 320 12 | Length 120 m |
| 1                                    | 1 320 14 | Length 140 m |
| 1                                    | 1 320 16 | Length 160 m |
| 1                                    | 1 320 18 | Length 180 m |
| 1                                    | 1 320 20 | Length 200 m |
| <b>12 SC simplex - 12 SC simplex</b> |          |              |
| 1                                    | 1 320 21 | Length 10 m  |
| 1                                    | 1 320 22 | Length 20 m  |
| 1                                    | 1 320 23 | Length 30 m  |
| 1                                    | 1 320 24 | Length 40 m  |
| 1                                    | 1 320 25 | Length 50 m  |
| 1                                    | 1 320 26 | Length 60 m  |
| 1                                    | 1 320 27 | Length 70 m  |
| 1                                    | 1 320 28 | Length 80 m  |
| 1                                    | 1 320 29 | Length 90 m  |
| 1                                    | 1 320 30 | Length 100 m |
| 1                                    | 1 320 32 | Length 120 m |
| 1                                    | 1 320 34 | Length 140 m |
| 1                                    | 1 320 36 | Length 160 m |
| 1                                    | 1 320 38 | Length 180 m |
| 1                                    | 1 320 40 | Length 200 m |

### Core™ LC/LC tight-buffer OM3 links

| Pack                                 | Cat.Nos  | Description  |
|--------------------------------------|----------|--------------|
| <b>6 LC simplex - 6 LC simplex</b>   |          |              |
| 1                                    | 1 320 41 | Length 10 m  |
| 1                                    | 1 320 42 | Length 20 m  |
| 1                                    | 1 320 43 | Length 30 m  |
| 1                                    | 1 320 44 | Length 40 m  |
| 1                                    | 1 320 45 | Length 50 m  |
| 1                                    | 1 320 46 | Length 60 m  |
| 1                                    | 1 320 47 | Length 70 m  |
| 1                                    | 1 320 48 | Length 80 m  |
| 1                                    | 1 320 49 | Length 90 m  |
| 1                                    | 1 320 50 | Length 100 m |
| 1                                    | 1 320 52 | Length 120 m |
| 1                                    | 1 320 54 | Length 140 m |
| 1                                    | 1 320 56 | Length 160 m |
| 1                                    | 1 320 58 | Length 180 m |
| 1                                    | 1 320 60 | Length 200 m |
| <b>12 LC simplex - 12 LC simplex</b> |          |              |
| 1                                    | 1 320 61 | Length 10 m  |
| 1                                    | 1 320 62 | Length 20 m  |
| 1                                    | 1 320 63 | Length 30 m  |
| 1                                    | 1 320 64 | Length 40 m  |
| 1                                    | 1 320 65 | Length 50 m  |
| 1                                    | 1 320 66 | Length 60 m  |
| 1                                    | 1 320 67 | Length 70 m  |
| 1                                    | 1 320 68 | Length 80 m  |
| 1                                    | 1 320 69 | Length 90 m  |
| 1                                    | 1 320 70 | Length 100 m |
| 1                                    | 1 320 72 | Length 120 m |
| 1                                    | 1 320 74 | Length 140 m |
| 1                                    | 1 320 76 | Length 160 m |
| 1                                    | 1 320 78 | Length 180 m |
| 1                                    | 1 320 80 | Length 200 m |

## Legrand cabling system, LCS<sup>3</sup> fiber optic High Density preterminated links



0 324 41

Selection chart p. 108-109

Supplied on a drum  
Micro cables for high density cassettes  
Aqua (OM3) and yellow (OS2) LSZH sheaths  
Supplied with test reports (photometry)  
Other configurations on request

### Ultra™ Fan-out/Fan-out preterminated High Density fiber optic links

With fan-out (2 mm output) for secure transition between the cable and the ends  
Low insertion loss for LC connector < 0.15 dB/connector

#### Fan-out/Fan-out OM3 micro cables

| Pack | Cat.Nos  | Description                 | Length (m) |
|------|----------|-----------------------------|------------|
| 1    | 0 324 01 | 6 LC duplex - 6 LC duplex   | 10         |
| 1    | 0 324 02 | 6 LC duplex - 6 LC duplex   | 20         |
| 1    | 0 324 03 | 6 LC duplex - 6 LC duplex   | 30         |
| 1    | 0 324 04 | 6 LC duplex - 6 LC duplex   | 40         |
| 1    | 0 324 05 | 6 LC duplex - 6 LC duplex   | 50         |
| 1    | 0 324 11 | 12 LC duplex - 12 LC duplex | 10         |
| 1    | 0 324 12 | 12 LC duplex - 12 LC duplex | 20         |
| 1    | 0 324 13 | 12 LC duplex - 12 LC duplex | 30         |
| 1    | 0 324 14 | 12 LC duplex - 12 LC duplex | 40         |
| 1    | 0 324 15 | 12 LC duplex - 12 LC duplex | 50         |

#### Fan-out/Fan-out OS2 micro cables

| Pack | Cat.Nos  | Description                 | Length (m) |
|------|----------|-----------------------------|------------|
| 1    | 0 324 21 | 6 LC duplex - 6 LC duplex   | 10         |
| 1    | 0 324 22 | 6 LC duplex - 6 LC duplex   | 20         |
| 1    | 0 324 23 | 6 LC duplex - 6 LC duplex   | 30         |
| 1    | 0 324 24 | 6 LC duplex - 6 LC duplex   | 40         |
| 1    | 0 324 25 | 6 LC duplex - 6 LC duplex   | 50         |
| 1    | 0 324 31 | 12 LC duplex - 12 LC duplex | 10         |
| 1    | 0 324 32 | 12 LC duplex - 12 LC duplex | 20         |
| 1    | 0 324 33 | 12 LC duplex - 12 LC duplex | 30         |
| 1    | 0 324 34 | 12 LC duplex - 12 LC duplex | 40         |
| 1    | 0 324 35 | 12 LC duplex - 12 LC duplex | 50         |

### Ultra™ MTP<sup>1</sup>/MTP<sup>1</sup> High Density preterminated fiber optic links

For connecting cassettes in High Density fiber optic panels and Ultra High Density drawers  
Female MTP<sup>1</sup>, A polarity  
Low insertion loss for MTP<sup>1</sup> connector < 0.35 dB/connector

#### MTP<sup>1</sup> OM3 micro cables

| Pack | Cat.Nos  | Description  | Length (m) |
|------|----------|--|------------|
| 1    | 0 324 41 | 12 MTP <sup>1</sup> -MTP <sup>1</sup> fiber optics | 10         |
| 1    | 0 324 42 | 12 MTP <sup>1</sup> -MTP <sup>1</sup> fiber optics | 20         |
| 1    | 0 324 43 | 12 MTP <sup>1</sup> -MTP <sup>1</sup> fiber optics | 30         |
| 1    | 0 324 44 | 12 MTP <sup>1</sup> -MTP <sup>1</sup> fiber optics | 40         |
| 1    | 0 324 45 | 12 MTP <sup>1</sup> -MTP <sup>1</sup> fiber optics | 50         |

#### MTP<sup>1</sup> OS2 micro cables

| Pack | Cat.Nos  | Description  | Length (m) |
|------|----------|--|------------|
| 1    | 0 324 51 | 12 MTP <sup>1</sup> -MTP <sup>1</sup> fiber optics | 10         |
| 1    | 0 324 52 | 12 MTP <sup>1</sup> -MTP <sup>1</sup> fiber optics | 20         |
| 1    | 0 324 53 | 12 MTP <sup>1</sup> -MTP <sup>1</sup> fiber optics | 30         |
| 1    | 0 324 54 | 12 MTP <sup>1</sup> -MTP <sup>1</sup> fiber optics | 40         |
| 1    | 0 324 55 | 12 MTP <sup>1</sup> -MTP <sup>1</sup> fiber optics | 50         |

1: MTP<sup>1</sup> is a registered trademark of US Conec Ltd

# Legrand cabling system, LCS<sup>3</sup> fiber optic

## 19" fiber optic drawers

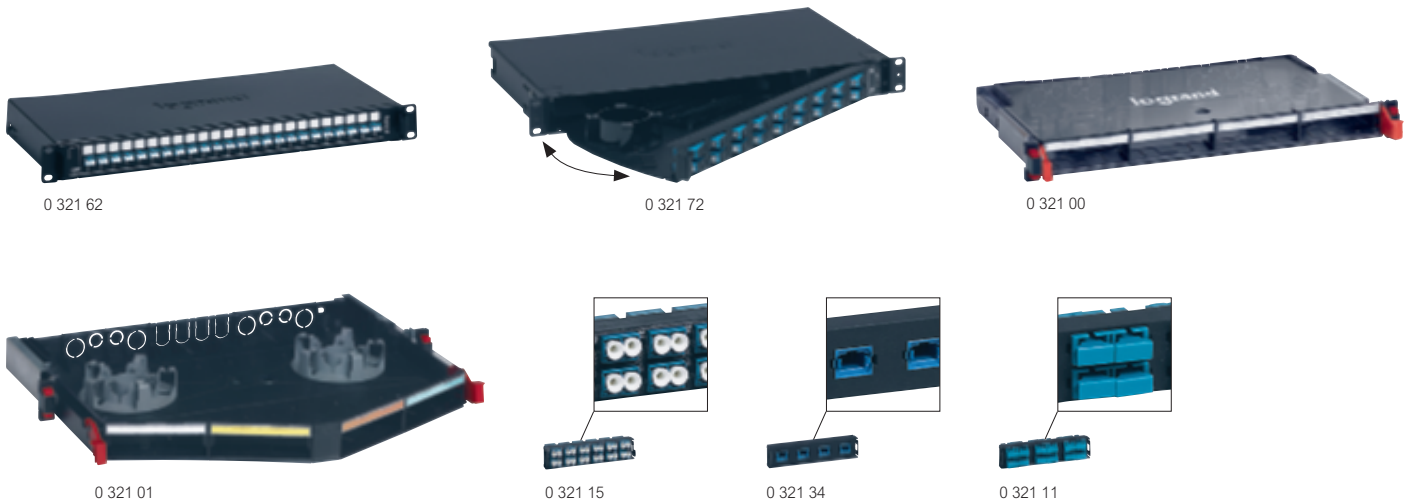

Selection chart p. 100-101

| Pack | Cat.Nos  | Equipped 19" fiber optic drawers  | Pack | Cat.Nos  | Fiber optic blocks  |          |  |
|------|----------|---|------|----------|---|----------|--|
|      |          | <p>Metal 19" pre-equipped fiber optic drawers, 4 cable entries, supplied with screw fixing kit, 2 cable glands (Ø 13.5 and 16 mm), coiling system and splice cassette</p> <p>Panel and optical ports marked on dedicated marking area</p> <p><b>Sliding</b></p> <p>End stop at a 30° angle</p> <p>Maximum capacity: 48 fibers in LC version, 24 fibers in ST and SC versions</p> <p>Depth 220 mm, height 1 U</p>  |      |          | <p>To be clipped directly onto modular fiber optic drawers to be equipped Cat.Nos 0 321 00/01 or onto fiber optic splice cassette Cat.No 0 321 41</p> <p><b>Single-mode fiber blocks (9/125 µm)</b></p> |          |  |
| 1    | 0 321 61 | SC duplex for 24 multimode fibers   | 1    | 0 321 17 | ST block for 6 single-mode fibers   |          |  |
| 1    | 0 321 62 | LC duplex for 48 multimode fibers   | 1    | 0 321 10 | SC duplex block for 6 single-mode fibers  |          |  |
| 1    | 0 321 63 | ST duplex for 24 multimode fibers   | 1    | 0 321 11 | SC duplex High Density block for 12 single-mode fibers  |          |  |
| 1    | 0 321 64 | SC duplex for 24 single-mode fibers   | 1    | 0 321 12 | SC APC duplex block for 6 single-mode fibers  |          |  |
| 1    | 0 321 65 | LC duplex for 48 single-mode fibers   | 1    | 0 321 13 | LC duplex block for 6 single-mode fibers  |          |  |
| 1    | 0 321 66 | SC APC duplex for 24 single-mode fibers   | 1    | 0 321 14 | LC duplex block for 12 single-mode fibers   |          |  |
| 1    | 0 321 67 | LC APC duplex for 48 single-mode fibers   | 1    | 0 321 15 | LC duplex High Density block for 24 single-mode fibers  |          |  |
|      |          | <p><b>Rotating</b></p> <p>Supplied with reversible left or right opening</p> <p>Maximum capacity: 72 fibers in LC version, 36 fibers in SC version</p> <p>Depth 260 mm, height 1 U</p>  |      |          | <p><b>Multimode fiber blocks (62.5 and 50/125 µm)</b></p>   |          |  |
| 1    | 0 321 71 | LC duplex for 72 multimode fibers   | 1    | 0 321 27 | ST block for 6 multimode fibers   |          |  |
| 1    | 0 321 72 | SC duplex for 36 multimode fibers   | 1    | 0 321 20 | SC duplex block for 6 multimode fibers  |          |  |
| 1    | 0 321 73 | LC duplex for 72 single-mode fibers   | 1    | 0 321 21 | SC duplex High Density block for 12 multimode fibers  |          |  |
| 1    | 0 321 74 | SC duplex for 36 single-mode fibers   | 1    | 0 321 23 | LC duplex block for 6 multimode fibers  |          |  |
|      |          | <p><b>Flat and angled 19" modular fiber optic drawers</b></p> <p>Metal 19" modular fiber optic drawers, 8 cable entries, supplied with 2 cable glands (Ø 13.5 and 9 mm), coiling system</p> <p>Equipped with the new-generation Quick-Fix system for automatic (screwless) mounting on enclosure or cabinet uprights</p> <p>Supplied with numbered labels</p> <p>Maximum capacity: 96 fibers in LC version, 48 in SC version or 24 in ST version</p> <p>Depth 290 mm, height 1U</p> |      |          | <p>1</p>  | 0 321 24 | LC duplex block for 12 multimode fibers              |
|      |          | <p><b>Sliding, equipped</b></p> <p>End stop at a 20° angle</p>  |      |          | <p>1</p>  | 0 321 25 | LC duplex High Density block for 24 multimode fibers |
| 1    | 0 321 02 | SC duplex for 24 multimode fibers   | 1    | 0 321 34 | Multimode 4 MTP <sup>1</sup> feedthrough adaptor, key up/ key down  |          |  |
| 1    | 0 321 04 | LC duplex for 48 multimode fibers   | 1    | 0 321 18 | Multimode 8 MTP <sup>1</sup> feedthrough adaptor, key up/ key down  |          |  |
| 1    | 0 321 06 | SC duplex for 24 single-mode fibers   | 1    | 0 321 36 | LC duplex block for 6 multimode fibers - aqua   |          |  |
|      |          | <p><b>Sliding, to be equipped with fiber optic blocks</b></p> <p>Takes any fiber optic block, up to 4 blocks maximum.</p> <p>End stop at a 20° angle</p>  | 1    | 0 321 37 | LC duplex block for 12 multimode fibers - aqua  |          |  |
| 1    | 0 321 00 | Empty drawer  |      |          | <p><b>RJ 45 copper block for fiber optic drawer</b></p>   |          |  |
|      |          | <p><b>Sliding, to be equipped with fiber optic blocks - angled</b></p> <p>Takes any fiber optic block, up to 4 blocks maximum.</p> <p>End stop at a 20° angle</p>   | 1    | 0 321 32 | To be clipped directly onto modular fiber optic drawers to be equipped Cat.Nos 0 321 00/01  |          |  |
| 1    | 0 321 01 | Empty drawer  |      |          | <p>Allows the mixing of fiber optic and copper</p> <p>Takes up to 5 RJ 45 connectors</p>  |          |  |
|      |          |   |      |          | <p><b>Accessories for fiber optic drawer to be equipped</b></p>   |          |  |
|      |          |   | 1    | 0 321 28 | <p><b>Accessory for receipt of a fan-out</b></p> <p>To be clipped onto the back of the drawer</p> <p>Enables the entry of preterminated links</p>   |          |  |
|      |          |   | 1    | 0 321 29 | <p><b>Blanking plate</b></p> <p>Blanking plate</p>  |          |  |
|      |          |   | 1    | 0 321 30 | <p><b>Cassette for pigtails</b></p> <p>Capacity: 24 fibers</p>  |          |  |
|      |          |   | 1    | 0 321 31 | <p><b>Coiling kit</b></p> <p>1 accessory</p>  |          |  |

1: MTP is a registered trademark of US Conec Ltd

# Legrand cabling system, LCS<sup>3</sup> fiber optic

## 19" High Density fiber optic panels (1/2/4 U) and patching kits



Panel 0 321 76 equipped with support 0 321 38 and slim cassettes 0 321 69/70



0 321 38



0 321 69

OM5 on request

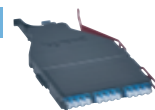

0 321 70



Selection chart p. 102-103

| Pack | Cat.Nos  | 19" High Density fiber optic panels  |
|------|----------|--|
|      |          | <b>Panels to be equipped with cassettes</b>  |
|      |          | Equipped with Quick-Fix system for automatic (screwless) mounting on enclosure or cabinet uprights   |
|      |          | To be equipped directly with a maximum of 4 automatically removable cassettes or 4 supports for slim cassettes Cat. No 0 321 38 per U  |
|      |          | Maximum capacity per U: 48 fibers in SC version, 24 fibers in ST version or 96 fibers in LC version  |
|      |          | 2U and 4U versions equipped with door and cord management at the front, and with cable management at the back  |
| 1    | 0 321 75 | 1 U height, depth 182 mm   |
| 1    | 0 321 76 | 2 U height, depth 393 mm   |
| 1    | 0 321 77 | 4 U height, depth 393 mm   |
|      |          | <b>Accessories for panels</b>  |
| 1    | 0 321 78 | Front cord management kit for 1 U panel<br>Fits on 1 U modular panel Cat.No 0 321 75<br>2 side cord guides and front door with integrated marking to ensure correct front and side cord management<br>Cord holder to be mounted on cassette to make it easier to pass cords through the side |
| 1    | 0 321 46 | Rear cable management accessory<br>Fits on 1 U panel Cat. No 0 321 75  |
| 1    | 0 321 28 | Accessory for receipt of a fan-out<br>To be clipped onto the back of the drawer<br>Enables the entry of preterminated links  |
| 1    | 0 321 22 | Copper cable management accessory  |
| 4    | 0 321 26 | Set of 4 cord holders<br>To be mounted on any cassette to make it easier to pass cords through the side  |
| 1    | 0 321 05 | Rear accessory for fixing 4 cable glands   |
|      |          | <b>Ultra™ preterminated MTP<sup>1</sup> High Density cassettes (MPO compatible)</b>  |
|      |          | For installation in modular panels<br>Cat. Nos 0 321 75/76/77 and in Zero-U kit<br>Cat. No 0 321 03  |
|      |          | Slim cassettes to be installed with support<br>Cat. No 0 321 38  |
|      |          | Sliding cassettes which can be removed automatically by simply pressing them, simplifying installation and maintenance<br>Removable from the front and back  |
|      |          | Multimode - Insertion Loss Max/Random <sup>2</sup> : 0.55 dB   |
|      |          | Single-mode - Insertion Loss Max/Random <sup>2</sup> : 0.6 dB  |
|      |          | Prewired, equipped at the rear with one or two male MTP <sup>1</sup> connectors with 12 fibers   |
|      |          | LC or SC connectors at the front   |
|      |          | <b>Ultra™ cassettes</b>  |
| 1    | 0 321 42 | Multimode OM4 cassette (50/125 μm)<br>24 LC fibers, A/C polarity   |
| 1    | 0 321 48 | Multimode OM4 cassette (50/125 μm)<br>12 LC fibers, A/C polarity   |
| 1    | 0 321 43 | Multimode OM4 cassette (50/125 μm)<br>12 SC fibers, A/C polarity   |
| 1    | 0 321 59 | Multimode OM4 cassette (50/125 μm)<br>12 SC fibers, universal  |
| 1    | 0 321 44 | Single-mode OS2 cassette (9/125 μm)<br>24 LC fibers, A/C polarity  |
| 1    | 0 321 49 | Single-mode OS2 cassette (9/125 μm)<br>12 LC fibers, A/C polarity  |
| 1    | 0 321 45 | Single-mode OS2 cassette (9/125 μm)<br>12 SC fibers, A/C polarity  |
| 1    | 0 321 60 | Single-mode OS2 cassette (9/125 μm)<br>12 SC fibers, universal   |

1: MTP is a registered trademark of US Conec Ltd

2: When mated with the same Legrand range (Ultra & Core) trunks and patch cords

| Pack | Cat.Nos  | Preterminated MTP <sup>1</sup> High Density cassettes (MPO compatible) (continued)  |
|------|----------|---|
|      |          | <b>Ultra™ slim cassettes</b>  |
|      |          | Support for High Density slim cassettes<br>Takes up to 2 High Density slim cassettes<br>Cat.Nos 0 321 68/69/70 and up to 2 blanking cassettes Cat.No 0 321 39 or 1 cassette + 1 blanking cassette   |
|      |          | Possibility to mix slim single-mode and multimode cassettes on the same support   |
| 1    | 0 321 69 | Slim multimode OM4 cassette (50/125 μm)<br>12 LC fibers, Universal polarity   |
| 1    | 0 321 68 | Slim multimode OM3 cassette (50/125 μm)<br>12 LC fibers, Universal polarity   |
| 1    | 0 321 70 | Slim single-mode OS2 cassette (9/125 μm)<br>12 LC fibers, Universal polarity  |
| 1    | 0 321 39 | Slim blanking module to be mounted (x2) on support<br>Cat.No 0 321 38 to fill gaps in the panel   |
|      |          | <b>Core™ pre-equipped cassettes</b>   |
|      |          | For installation in modular panels<br>Cat. Nos 0 321 75/76/77 and Zero-U kit Cat.No 0 321 03  |
|      |          | Pre-equipped cassettes with fitted fiber optic block + sets of 6 or 12 OM3 pigtails   |
|      |          | Sliding cassettes which can be removed automatically by simply pressing them, simplifying installation and maintenance<br>Removable from the front  |
|      |          | <b>Pre-equipped cassettes for multimode installation (50/125 μm)</b>  |
| 1    | 0 321 80 | Equipped with 1 SC duplex block for 6 fibers  |
| 1    | 0 321 81 | Equipped with 1 LC duplex block for 6 fibers  |
| 1    | 0 321 82 | Equipped with 1 SC duplex block for 12 fibers   |
| 1    | 0 321 83 | Equipped with 1 LC duplex block for 12 fibers   |
|      |          | <b>Pre-equipped cassettes for single-mode installation (9/125 μm)</b>   |
| 1    | 0 321 84 | Equipped with 1 SC duplex block for 6 fibers  |
| 1    | 0 321 85 | Equipped with 1 LC duplex block for 6 fibers  |
| 1    | 0 321 86 | Equipped with 1 SC duplex block for 12 fibers   |
| 1    | 0 321 87 | Equipped with 1 LC duplex block for 12 fibers   |
|      |          | <b>Cassettes to be equipped and blanking plate</b>  |
|      |          | For installation in modular panels<br>Cat. Nos 0 321 75/76/77 and Zero-U kit<br>Cat. No 0 321 03  |
|      |          | Sliding cassettes which can be removed automatically by simply pressing them, simplifying installation and maintenance<br>Removable from the front  |
| 1    | 0 321 41 | <b>Fiber optic splice cassette</b><br>Takes any modular fiber optic block   |
| 1    | 0 337 57 | <b>Blanking cassette</b><br>To be used to fill gaps in the panel  |
| 1    | 0 321 55 | <b>Copper cassette to be equipped</b><br>Takes six Cat. 5e, 6 and 6A copper connectors  |
|      |          | <b>Patching kits</b>  |
|      |          | <b>1 U to 4 U patching kit</b><br>Compatible with all LCS <sup>3</sup> fiber optic and copper 19" panels<br>Supplied with top protection, cable guides and specific accessories for installation on cable trays, wire meshed cable trays (Cablofil) and cabinets  |
| 1    | 0 321 89 |   |
|      |          | <b>Zero-U patching kit</b><br>To bring few fiber optic or copper connections outside 19" panels<br>Takes 1 cassette (fiber optic preterminated cassettes, pre equipped cassettes, fiber optic splice cassette or RJ 45 copper cassette)<br>Supplied with a comprehensive range of accessories for fixing in or outside enclosures (raised access floors, cable trays, walls, ceiling) |
| 1    | 0 321 03 |   |

## Legrand cabling system, LCS<sup>3</sup> Meet-Me Room solutions - cassettes, frames and accessory



C49001 (equipped with cassettes)



C42002

Can be used in combination with other LCS<sup>3</sup> solutions to create an optimal connectivity solution for the entire data center

| Pack | Cat.Nos | ODF splice-patch cassettes   |
|------|---------|--|
|      |         | Designed for fast and easy splicing of large amounts of fibers<br>Fully scalable: up to four cassettes on 1U allow for finishing up to 96 fibers, including Air Blown Fibers<br>Completely preloaded delivery including adapters, pigtails, splice trays, heat shrink splice protectors and mounting materials               |
| 1    | C40001  | <b>24 fibers - single-mode - LC/PC cassettes</b><br>Left splice-patch cassette   |
| 1    | C40002  | Right splice-patch cassette  |
| 1    | C40003  | <b>24 fibers - single-mode - LC/APC cassettes</b><br>Left splice-patch cassette  |
| 1    | C40004  | Right splice-patch cassette  |
| 1    | C49001  | <b>Empty base panel</b><br>Empty base panel (1U) for ODF splice-patch cassettes  |
|      |         | <b>ODF patch-open end cassettes</b><br>Designed for situations where a distribution box or outside-plant splice box is used for splicing<br>Cable diameter 4.5 mm: can be used outside plant in combination with a (multi)duct<br>Cassettes equipped with an open-end cable length 15 m (other lengths available on request) |
| 1    | C42001  | <b>24 fibers - single-mode - LC/PC cassettes</b><br>Left patch-open end cassette   |
| 1    | C42002  | Right patch-open end cassette  |
| 1    | C42003  | <b>24 fibers - single-mode - LC/APC cassettes</b><br>Left patch-open end cassette  |
| 1    | C42004  | Right patch-open end cassette  |
| 1    | C49002  | <b>Mounting plates</b><br>19" mounting plates for ODF patch-open end cassettes   |
|      |         | <b>ODF frames</b><br>Dimensions: H 2050 x W 900 x D 400 mm<br>42U<br>Completely closed: the most critical connections in the data center are well protected against external influences<br>Delivered fully pre-assembled including side panels, back panel, doors, roof and integrated cable management                      |
| 1    | C44001  | Frame with cable management on the left  |
| 1    | C44002  | Frame with cable management on the right   |
| 25   | C49004  | <b>Accessory</b><br>Heat shrink splice protectors 40mm   |

## LEGRAND CABLING SYSTEM

# LCS<sup>3</sup>

## NEXT LEVEL

# DATA CENTER SOLUTIONS!

A data center must accommodate IT infrastructure in the most efficient way possible. Infrastructure needs the space to grow and evolve with new circumstances, technology, and user requirements.

**With LCS<sup>3</sup>, Legrand offers an extremely flexible and modular cabinet platform that grows and evolve with you, no matter what your requirements are now and in the future.**



**SMART**  
Unlimited possibilities



**SOLID**  
Next level reliability



**SECURE**  
Keep your data safe



**SUSTAINABLE**  
Next level energy efficiency

# Legrand cabling system, LCS<sup>3</sup> fiber optic

## 19" UHD<sup>1</sup> fiber optic drawers

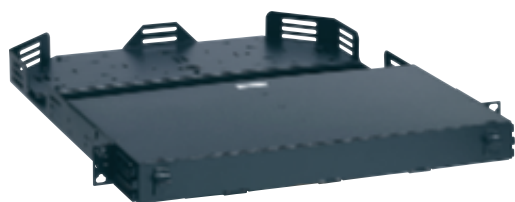

0 321 50

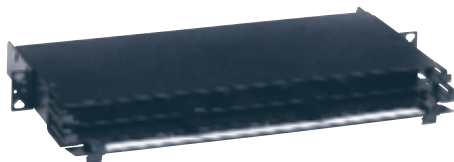

0 321 90

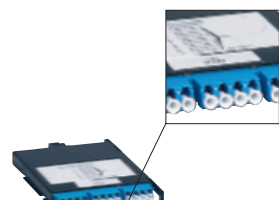

0 321 55

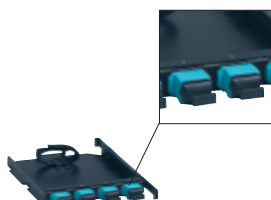

0 321 56

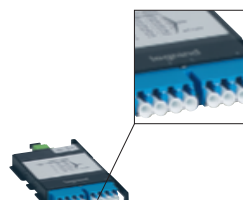

0 321 94

Selection chart p. 104-105

| Pack | Cat.Nos  | UHD <sup>1</sup> modular fiber optic drawers, to be equipped with 12-fiber cassettes   |
|------|----------|--|
| 1    | 0 321 51 | Fixed modular chassis for holding cassettes<br>4 U maximum capacity (holds up to 48 cassettes):<br>576 LC fibers<br>2 U maximum capacity (holds up to 24 cassettes):<br>288 LC fibers<br>1 U maximum capacity (holds up to 12 cassettes):<br>144 LC fibers<br><b>Fiber optic drawer with cord management at the front for 12-fiber cassettes</b><br>1 U<br><b>Fiber optic drawers with cord management at the front and back for 12-fiber cassettes</b><br>Depth: 595 mm   |
| 1    | 0 321 50 | 1 U  |
| 1    | 0 321 52 | 2 U  |
| 1    | 0 321 53 | 4 U  |
| 1    | 0 321 54 | <b>UHD<sup>1</sup> 12-fiber cassettes</b><br>Clip directly into fiber optic drawers<br>Cat.Nos. 0 321 50/51/52/53<br>Cassettes slide into above chassis<br>Cassettes can be removed from the front and back<br>MPO high-performance cassettes<br>Low insertion loss < 0.35 dB<br>A/C polarity<br><b>Multimode OM4 cassettes (50/125 μm)</b><br>For 50/125 μm multimode installation, OM4 type<br>MPO cassette (MTP <sup>2</sup> compatible)<br>12 OM4 LC fibers, polarity A/C<br><b>Single-mode OS2 cassette (9/125 μm)</b><br>For 9/125 μm single-mode installation, OS2 type<br>MPO cassette (MTP <sup>2</sup> compatible)<br>12 OS2 LC fibers, polarity A/C |
| 1    | 0 321 55 |  |
| 1    | 0 321 56 | <b>Adaptors for 12-fiber UHD<sup>1</sup> installation</b><br>Clip into UHD <sup>1</sup> fiber optic drawers for 12-fiber cassettes Cat.Nos 0 321 50/51/52/53<br><b>MPO adaptors (MTP<sup>2</sup> compatible)</b><br>Multimode 4 MTP <sup>2</sup> adaptor - key up/key down<br>Single-mode 4 MTP <sup>2</sup> adaptor - key up/key down<br><b>LC adaptor</b><br>12 LC multimode adaptor   |
| 1    | 0 321 57 |  |
| 1    | 0 321 58 |  |

| Pack | Cat.Nos  | UHD <sup>1</sup> modular fiber optic drawers, to be equipped with 8-fiber cassettes  |
|------|----------|--|
| 1    | 0 321 90 | Fixed modular chassis for holding cassettes<br>4 U maximum capacity (holds up to 72 cassettes):<br>- 576 LC fibers<br>2 U maximum capacity (holds up to 36 cassettes):<br>- 288 LC fibers<br>1 U maximum capacity (holds up to 18 cassettes)<br>- 144 LC fibers<br><b>Fiber optic drawers with cord management at the front and back for 8-fiber cassettes</b><br>Depth: 595 mm  |
| 1    | 0 321 91 | 1 U  |
| 1    | 0 321 92 | 2 U  |
| 1    | 0 321 92 | 4 U  |
| 1    | 0 321 93 | <b>UHD<sup>1</sup> 8-fiber cassettes</b><br>Clip directly into fiber optic drawers<br>Cat.Nos. 0 321 90/91/92<br>Cassettes slide into above chassis<br>Cassettes can be removed from the front and back<br>MPO high-performance cassettes<br>Low insertion loss < 0.35 dB<br>Universal polarity<br><b>Multimode OM4 cassettes (50/125 μm)</b><br>For 50/125 μm multimode installation, OM4 type<br>MPO cassette (MTP <sup>2</sup> compatible)<br>8 OM4 LC fibers, universal polarity<br><b>Single-mode OS2 cassette (9/125 μm)</b><br>For 9/125 μm single-mode installation, OS2 type<br>MPO cassette (MTP <sup>2</sup> compatible)<br>8 OS2 LC fibers, universal polarity |
| 1    | 0 321 94 |  |
| 1    | 0 321 95 | <b>Adaptors for 8-fiber UHD<sup>1</sup> installation</b><br>Clip into UHD <sup>1</sup> fiber optic drawers for 8-fiber cassettes Cat.Nos 0 321 90/91/92<br><b>MPO adaptors (MTP<sup>2</sup> compatible)</b><br>Multimode 4 MTP <sup>2</sup> adaptor - key up/key down<br>Single-mode 4 MTP <sup>2</sup> adaptor - key up/key down<br><b>LC adaptors</b><br>8 LC multimode adaptor<br>8 LC single-mode adaptor<br>8 LC-APC single-mode adaptor  |
| 1    | 0 321 96 |  |
| 1    | 0 321 97 |  |
| 1    | 0 321 98 |  |
| 1    | 0 321 99 |  |

1: Ultra High Density  
2: MTP is a registered trademark of US Conec Ltd

## Legrand cabling system, LCS<sup>3</sup> fiber optic pigtails, glue-on connectors and fan-out units

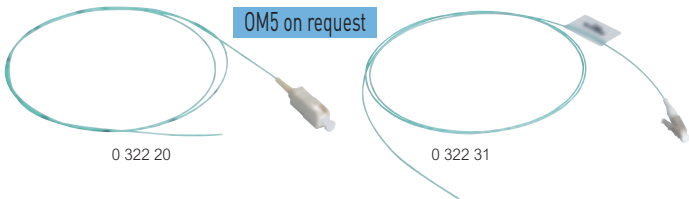

Selection chart p. 106-107

| Pack | Cat.Nos        | Core™ pigtails   |
|------|----------------|--|
|      |                | <p>LSZH<br/>For making quick, reliable and high-performance fiber optic cable connections on site:<br/>- OM2/OM3/OM4 IL Typical/Master = 0.15 dB<br/>- OS2 IL Typical/Master = 0.18 dB<br/>Compatible with all commercially-available splicers</p> |
| 1    | 1 m   0 322 20 | <p><b>50/125 µm - OM3 (PC)</b><br/>SC connectors<br/>LC connectors<br/>ST connectors</p>   |
| 1    | 2 m   0 322 21 |  |
| 1    | 0 322 22       |  |
| 1    | 0 322 30       | <p><b>50/125 µm - OM4 (PC)</b><br/>SC connectors<br/>LC connectors<br/>ST connectors</p>   |
| 1    | 0 322 31       |  |
| 1    | 0 322 32       |  |
| 1    | 0 322 40       | <p><b>9/125 µm - OS2 (APC or UPC) - OS1 compatible</b><br/>SC-APC connectors<br/>SC-UPC connectors<br/>LC-APC connectors<br/>LC-UPC connectors<br/>ST-UPC connectors</p>   |
| 1    | 0 322 41       |  |
| 1    | 0 322 42       |  |
| 1    | 0 322 43       |  |
| 1    | 0 322 44       |  |
| 1    | 0 322 49       |  |
|      |                | <p><b>Sets of 12 LC pigtails</b><br/>1m length - 12 different colors</p>   |
| 1    | 0 326 24       | 12 OS2 LC-UPC pigtails   |
| 1    | 0 326 26       | 12 OM3 LC-UPC pigtails   |
| 1    | 0 326 71       | 12 OM4 LC-UPC pigtails   |
|      |                | <p><b>Heat-shrinkable sleeve for pigtails</b><br/>40 mm - pack of 50 sleeves</p>   |
| 1    | 0 327 44       |  |
|      |                | <p><b>50/125 and 62,5/125 µm glue-on connectors</b><br/>Supplied with 900 µm sleeve<br/>Connectors with ceramic ferrule<br/>Typical attenuation: 0.3 dB</p>  |
| 10   | 0 331 47       | SC connectors  |
| 10   | 0 331 00       | LC connectors  |
|      |                | <p><b>Fan-out units</b><br/>For 900 µm sheathing of optical fibers<br/>Take 250 µm fiber diameters</p>   |
| 1    | 0 330 48       | 6-fiber fan-out unit   |
| 1    | 0 330 49       | 12-fiber fan-out unit  |

## Legrand cabling system, LCS<sup>3</sup> fiber optic case and quick-connect connectors

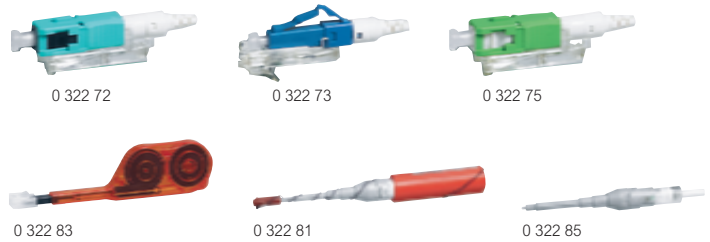
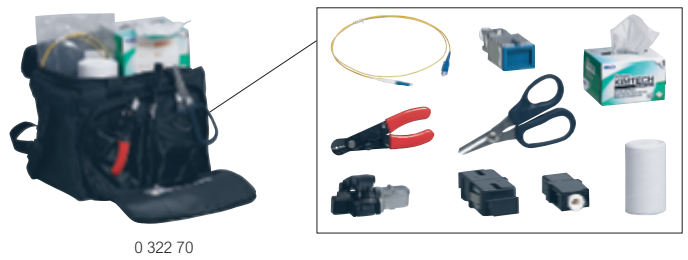

| Pack | Cat.Nos  | Tool case for preparing optical fiber for quick-connect fiber optic connectors   |
|------|----------|--|
| 1    | 0 322 70 | <p>Provides the tools required for preparing optical cables, for carrying out initial tests of the connection of fibers to connectors and accessories for easy connection in all situations<br/>Comprises:<br/>- Precision cleaver<br/>- Kevlar stripping and cutting tool<br/>- Visual fault locator<br/>- Installation instructions and video<br/>- Accessories (cleaners, felt tip pen, bin, etc)</p>   |
|      |          | <p><b>Quick-connect connectors</b><br/>Connection can be made with case Cat.No 0 322 70<br/>Quick-connect, reliable and reusable up to 5 times<br/>To be used to lock the fiber inside the connector<br/>An indicator light is used to test the connection<br/>No glue or polishing needed<br/>Can be installed on 900 µm fiber optics<br/>For 250 µm fiber, use the special tubes supplied with the connectors; typical IL: multimode OM3/OM4 = 0.1 dB and single-mode OS2 = 0.2 dB (PC) and 0.3 dB (APC)</p> |
|      |          | <p><b>OM3/OM4 multimode connectors</b><br/>Set of 12 connectors</p>  |
| 12   | 0 322 71 | LC PC 50/125 µm, 900/250 µm  |
| 12   | 0 322 72 | SC PC 50/125 µm, 900/250 µm  |
|      |          | <p><b>OS2 single-mode connectors</b><br/>Set of 12 connectors</p>  |
| 12   | 0 322 73 | LC UPC 9/125 µm, 900/250 µm  |
| 12   | 0 322 74 | SC UPC 9/125 µm, 900/250 µm  |
| 12   | 0 322 75 | SC APC 9/125 µm, 900/250 µm  |
|      |          | <p><b>Precision cleaver for updating case</b><br/><b>Cat.Nos 0 326 90</b></p>  |
| 1    | 0 322 80 | Enables precision-cutting of fiber optics and the use of quick-connect connectors Cat.Nos 0 322 71 to 0 322 75 with case Cat.No 0 326 90   |
|      |          | <p><b>Fiber optic cleaning accessories</b></p>   |
| 1    | 0 322 83 | MPO/MTP <sup>1</sup> ferrule cleaner   |
| 1    | 0 322 81 | LC ferrule cleaner (PC/APC)  |
| 1    | 0 322 82 | SC ferrule cleaner (PC/APC)  |
| 1    | 0 322 84 | LC replacement cartridge   |
| 1    | 0 322 85 | SC replacement cartridge   |
| 1    | 0 322 76 | Fiber stripper   |
| 1    | 0 322 77 | Wipes  |
| 1    | 0 322 78 | Cleaning spray   |

1: MTP is a registered trademark of US Conec Ltd

## Legrand cabling system, LCS<sup>3</sup> fiber optic

### Core™ fiber patch cords

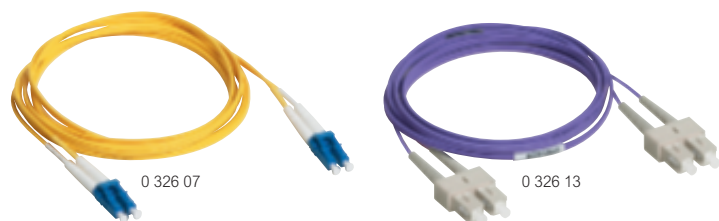

Selection chart p. 106-107

Fitted at each end with 2 connectors with ceramic ferrule  
Individually packed and tested (report supplied)  
Max. optical losses/Master: 0.25 dB  
LSZH Zipcord sheath

| Pack | Cat.Nos  | OS2 single-mode fiber optic cords (9/125 μm)                       |
|------|----------|--|
|      |          | For 9/125 μm single-mode installations, OS2 type<br>Yellow sheaths |
| 3    | 0 326 00 | <b>SC/SC duplex cords</b><br>Length: 1 m                           |
| 3    | 0 326 01 | Length: 2 m  |
| 3    | 0 326 02 | Length: 3 m  |
| 3    | 0 326 03 | <b>SC/LC duplex cords</b><br>Length: 1 m                           |
| 3    | 0 326 04 | Length: 2 m  |
| 3    | 0 326 05 | Length: 3 m  |
| 3    | 0 326 28 | <b>LC/LC duplex cords</b><br>Length: 0.5 m                         |
| 3    | 0 326 06 | Length: 1 m  |
| 3    | 0 326 07 | Length: 2 m  |
| 3    | 0 326 08 | Length: 3 m  |
| 3    | 0 326 29 | Length: 5 m  |
|      |          | <b>OM3 multimode fiber optic cords (50/125 μm)</b>                 |
|      |          | For 50/125 μm multimode installations, OM3 type<br>Aqua sheaths    |
| 3    | 0 326 09 | <b>SC/SC duplex cords</b><br>Length: 1 m                           |
| 3    | 0 326 10 | Length: 2 m  |
| 3    | 0 326 11 | Length: 3 m  |
| 3    | 0 326 12 | <b>SC/LC duplex cords</b><br>Length: 1 m                           |
| 3    | 0 326 13 | Length: 2 m  |
| 3    | 0 326 14 | Length: 3 m  |
| 3    | 0 326 15 | <b>LC/LC duplex cords</b><br>Length: 1 m                           |
| 3    | 0 326 16 | Length: 2 m  |
| 3    | 0 326 17 | Length: 3 m  |
|      |          | <b>OM4 multimode fiber optic cords (50/125 μm)</b>                 |
|      |          | For 50/125 μm multimode installations, OM4 type<br>Aqua sheaths    |
| 5    | 0 322 60 | <b>SC/SC duplex cords</b><br>Length: 1 m                           |
| 5    | 0 322 61 | Length: 2 m  |
| 5    | 0 322 62 | Length: 3 m  |
| 5    | 0 322 63 | <b>SC/LC duplex cords</b><br>Length: 1 m                           |
| 5    | 0 322 64 | Length: 2 m  |
| 5    | 0 322 65 | Length: 3 m  |
| 5    | 0 322 66 | <b>LC/LC duplex cords</b><br>Length: 1 m                           |
| 5    | 0 322 67 | Length: 2 m  |
| 5    | 0 322 68 | Length: 3 m  |

## Legrand cabling system, LCS<sup>3</sup> fiber optic

### Ultra™ fiber patch cords



Selection chart p. 106-107

Fitted at each end with 2 connectors with ceramic ferrule  
Individually packed and tested (report supplied)  
Max. optical losses/Master: 0.15 dB  
LSZH Zipcord sheath

| Pack | Cat.Nos  | OS2 single-mode fiber optic cords (9/125 μm)                              |
|------|----------|---|
|      |          | For 9/125 μm single-mode installations, OS2 type<br>Yellow sheaths        |
| 5    | 0 325 27 | <b>SC/SC duplex cords</b><br>Length: 1 m                                  |
| 5    | 0 325 28 | Length: 2 m   |
| 5    | 0 325 29 | Length: 3 m   |
| 5    | 0 325 30 | <b>SC/LC duplex cords</b><br>Length: 1 m                                  |
| 5    | 0 325 31 | Length: 2 m   |
| 5    | 0 325 32 | Length: 3 m   |
| 5    | 0 325 33 | <b>LC/LC duplex cords</b><br>Length: 1 m                                  |
| 5    | 0 325 34 | Length: 2 m   |
| 5    | 0 325 35 | Length: 3 m   |
| 5    | 0 325 36 | Length: 5 m   |
| 3    | 0 326 86 | <b>LC/LC Uniboot duplex cords</b><br>Reversible polarity<br>Length: 1 m   |
| 3    | 0 326 87 | Length: 2 m   |
| 3    | 0 326 88 | Length: 3 m   |
| 3    | 0 326 89 | Length: 5 m   |
| 3    | 0 326 92 | Length: 10 m  |
|      |          | <b>OM4 multimode fiber optic cords (50/125 μm)</b>                        |
|      |          | For 50/125 μm multimode installations, OM4 type<br>Aqua sheaths           |
| 3    | 0 326 30 | <b>SC/SC duplex cords</b><br>Length: 1 m                                  |
| 3    | 0 326 31 | Length: 2 m   |
| 3    | 0 326 32 | Length: 3 m   |
| 3    | 0 326 33 | <b>LC/LC duplex cords</b><br>Length: 0.5 m                                |
| 3    | 0 326 34 | Length: 1 m   |
| 3    | 0 326 35 | Length: 2 m   |
| 3    | 0 326 36 | Length: 3 m   |
| 3    | 0 326 37 | Length: 5 m   |
| 3    | 0 326 95 | <b>LC/LC Uniboot duplex cords</b><br>Reversible polarity<br>Length: 0.5 m |
| 3    | 0 326 96 | Length: 1 m   |
| 3    | 0 326 97 | Length: 2 m   |
| 3    | 0 326 98 | Length: 3 m   |
| 3    | 0 326 99 | Length: 5 m   |



## Legrand cabling system, LCS<sup>3</sup> fiber optic feedthrough sockets



| Pack | Cat.Nos   | Fiber optic feedthrough sockets   |
|------|-----------|---|
| 1    | 0 786 16  | <p>Equipped with a duplex feedthrough<br/>To be used to connect two fibers<br/>(equipped with their connector)<br/>Supplied with protection caps<br/>Equipped with a transparent marker-holder<br/>2 modules</p> <p><b>2 x ST socket</b><br/>Bayonet connection (STII compatible)</p> <p> ○ White</p> |
| 1    | 0 786 17  | <p><b>2 x SC socket</b><br/>Push-pull connection</p> <p> ○ White</p>  |
| 1    | 0 786 18  | <p><b>2 x LC socket</b><br/>Push-pull connection</p> <p> ○ White</p>  |
| 1    | 0 786 14  | <p><b>2 x SC/APC socket</b><br/>Push-pull connection<br/>With shutters</p> <p> ○ White</p>  |
| 1    | 0 794 15L | <p> ● Aluminium</p>   |
| 1    | 0 791 14L | <p> ● Matt Black</p>  |

## AUDIO VIDEO SYSTEM

# The right system to meet your needs

A wide range of technologies (HDMI, Display Port, HD15, Jack, RCA) to suit the location and the user requirements.



■ MediaHub



■ HDMI preterminated female socket



■ Audio socket



■ Cords and cables

- Quick installation
- Easy connection
- Optimum performance

# Audio/video system

audio/video sockets



0 789 12

5 722 69 + plate

For technical information, see e-catalogue

| Pack | Cat.Nos            |                    | <b>Multiparticipant HDMI audio/video projection</b><br><b>Selector switch transmitters</b><br>Allows different participants in the room to play the presentation on their PC by pressing the control takeover button without disconnecting the video projector cable<br>For use with other transmitters (up to 8 max.) and a receiver connected to the video projector. High Speed HDMI® with Ethernet cords are used for connection (not supplied, see p. 147)<br>2 modules |
|------|--------------------|--------------------|--|
| 1    | Mosaic<br>0 789 12 | Arteor<br>5 720 98 |  |
| 1    | 0 789 13           | 5 720 99           | <b>Receivers</b><br>Transmits audio/video from the transmitters to the video projector and supplies power to the receivers. The receiver and the first transmitter are connected by a High Speed® Ethernet cable (not supplied, see p. 147)<br>24 V power supply (supplied)<br>2 modules   |

| Pack | Cat.Nos            |                        | <b>MediaHub</b><br>Allows the users to:<br>- watch films located on a PC or a camcorder on their TV: HDMI connector<br>- watch the contents of a USB stick on their TV: USB data connection<br>- charge devices: USB sockets (total power: 3 A)<br>- listen to music currently located on their smartphone/tablet, etc. : Bluetooth function<br>Inputs: 2 USB chargers including 1 USB data, HDMI, Bluetooth audio<br>Output: HDMI and USB data<br>Power supply with transformer (supplied)<br>Supplied with cover plate and support<br>2 modules |
|------|--------------------|------------------------|---|
| 1    | Arteor<br>5 722 69 |                        |   |
| 1    | 5 727 69           | ○ White<br>● Magnesium |   |

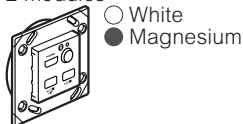

# Audio/video system

audio/video sockets

## Multiparticipant HDMI audio/video projection

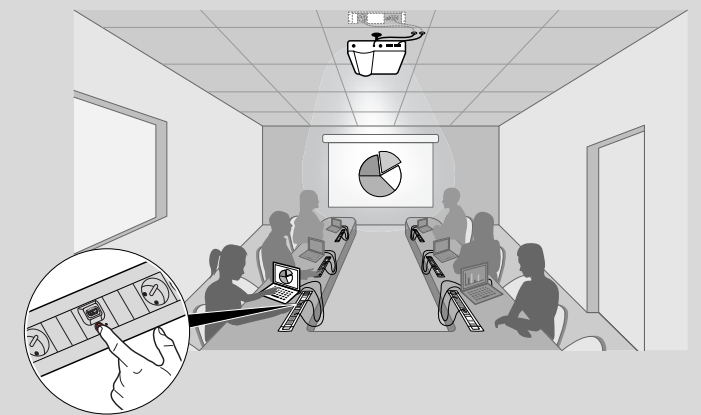
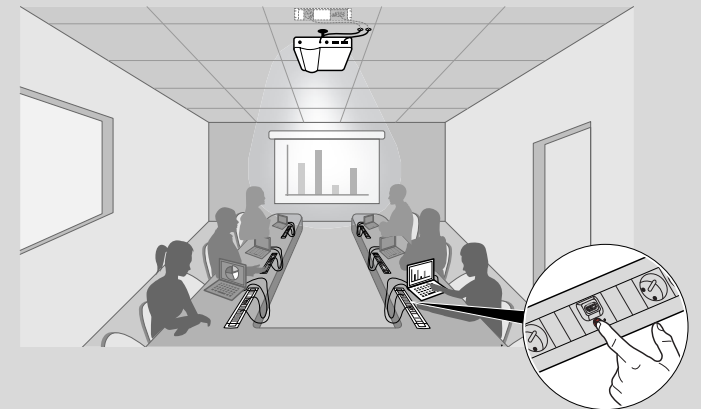

## MediaHub

Charger, Bluetooth data, HDMI and USB in 1 product: connect these devices to view their contents on your TV

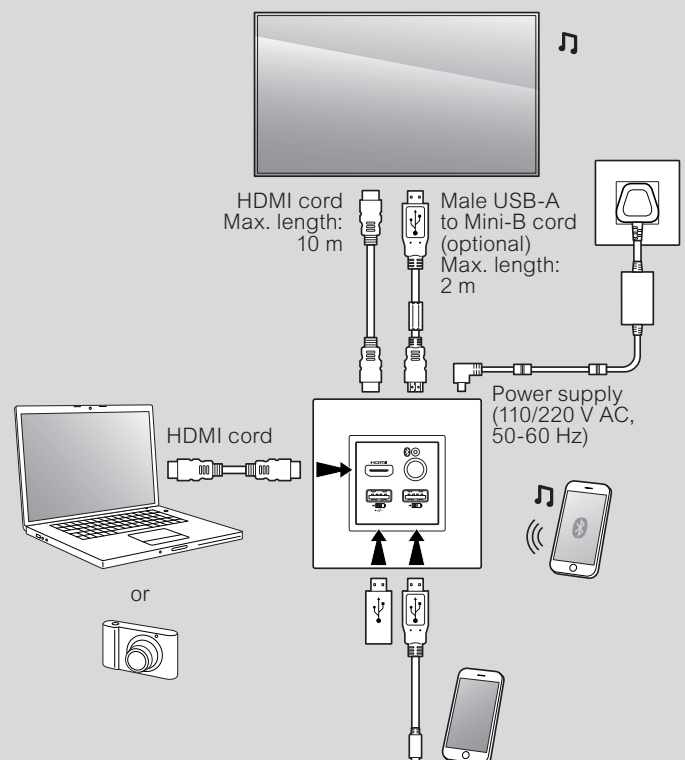

# Audio/video system

## audio/video sockets (continued)



| Pack | Cat.Nos            |                    | Type-A HDMI sockets  |
|------|--------------------|--------------------|--|
|      |                    |                    | For transmitting High Definition digital audio/video streams between a source (computer, DVD or Blu-Ray player, etc) and a compatible receiver (TV, video projector, etc)<br>Max. length between 2 sockets: 10 m |
|      |                    |                    | <b>HDMI 2.0 preterminated sockets - 1 module</b><br>Equipped with a 15 cm cord and 2 female connectors   |
| 1    | Mosaic<br>0 787 78 | Arteor<br>5 720 96 | <ul style="list-style-type: none"> <li>○ White</li> <li>● Aluminium</li> <li>● Matt Black</li> <li>● Magnesium</li> <li>● Champagne</li> <li>● Soft Alu</li> </ul>   |
| 1    | 0 793 78           |                    |  |
| 1    | 0 794 78L          |                    |  |
| 1    |                    | 5 725 96           |  |
| 1    |                    | 5 725 18           |  |
| 1    |                    | 5 725 17           |  |
|      |                    |                    | <b>HDMI 2.0 preterminated sockets - 2 modules</b>  |
| 1    | 0 789 79L          | 5 722 99           | <ul style="list-style-type: none"> <li>○ White</li> <li>● Aluminium</li> <li>● Matt Black</li> <li>● Magnesium</li> <li>● Champagne</li> <li>● Soft Alu</li> </ul>   |
| 1    | 0 792 79L          |                    |  |
| 1    | 0 794 79L          |                    |  |
| 1    |                    | 5 725 99           |  |
| 1    |                    | 5 723 46           |  |
| 1    |                    | 5 723 45           |  |

|   |          |  |
|---|----------|--|
| 1 | 0 517 38 | <b>HDMI audio/video extender</b><br><br>For connecting HDMI terminals up to 60 m apart<br>The kit comprises transmitter and receiver units as well as power supplies<br>The transmitter and receiver are linked by an RJ 45/RJ 45 cable (not supplied)<br>Compatible with 4K, 3D, EDID and HDCP<br>Infrared controller included<br>Certified HDBaseT |
|---|----------|--|

| Pack | Cat.Nos            |                    | Display Port sockets  |
|------|--------------------|--------------------|---|
|      |                    |                    | For transmitting High Definition digital audio/video streams between a source (laptop computer, DVD or Blu-Ray player, etc) and a compatible receiver (video projector, TV, etc)<br>Max. length between 2 sockets: 10 m |
|      |                    |                    | <b>Preterminated sockets - 1 module</b><br>Equipped with a 15 cm cord and 2 female connectors   |
| 1    | Mosaic<br>0 787 91 | Arteor<br>5 720 90 | <ul style="list-style-type: none"> <li>○ White</li> <li>● Magnesium</li> </ul>  |
| 1    |                    | 5 725 90           |   |

| Pack | Cat.Nos            |                    | Female HD15 sockets  |
|------|--------------------|--------------------|--|
|      |                    |                    | For transmitting analogue video streams between a source (computer) and a compatible receiver (video projector, TV, computer screen, etc)<br>VGA to UXGA resolution<br>Max. length between 2 sockets: 15 m |
|      |                    |                    | <b>Preterminated sockets - 1 module</b><br>Equipped with a 15 cm cord and 2 female connectors  |
| 1    | Mosaic<br>0 787 77 | Arteor<br>5 720 97 | <ul style="list-style-type: none"> <li>○ White</li> <li>● Aluminium</li> <li>● Magnesium</li> </ul>  |
| 1    | 0 793 77           |                    |  |
| 1    |                    | 5 725 97           |  |
|      |                    |                    | <b>Screw-type sockets - 2 modules</b>  |
| 1    | 0 787 57           | 5 722 82           | <ul style="list-style-type: none"> <li>○ White</li> </ul>  |
|      |                    |                    | <b>Screw-type sockets + 3.5 mm Jack - 2 modules</b>  |
| 1    | 0 787 74           | 5 722 88           | <ul style="list-style-type: none"> <li>○ White</li> <li>● Magnesium</li> </ul>   |
| 1    |                    | 5 727 88           |  |
|      |                    |                    | <b>Solder-type sockets - 1 module</b>  |
| 1    | 0 787 72           | 5 722 79           | <ul style="list-style-type: none"> <li>○ White</li> </ul>  |

|   |                    |   |
|---|--------------------|---|
| 1 | Mosaic<br>0 787 99 | <b>Infrared ON/Standby controls for video projector</b><br><br>To be used to switch on a video projector or set it to standby<br>Must be combined with a push-button<br>Work with any infrared video projector or other product with an infrared remote control (TV, air conditioning, games console, etc) using a learning process<br>Installed near the switch controlling the lighting in a room, the push-button sends the command to the IR ON/Standby control which replaces the manufacturer's remote control and makes it easier to switch the video projector on and off |
|---|--------------------|---|

1: Can be installed in receptacles for floor sockets

Audio/video cords,  
See p. 147-148



Multiparicipant HDMI audio/video projection,  
See p. 144

# Audio/video system

## audio/video sockets (continued)



| Pack | Cat.Nos            |                    | 3.5 mm female Jack sockets   |
|------|--------------------|--------------------|--|
|      |                    |                    | For making audio links   |
|      |                    |                    | <b>Preterminated sockets - 1 module</b>  |
|      |                    |                    | Equipped with a 15 cm cord and 2 female connectors   |
| 1    | Mosaic<br>0 787 79 | Arteor<br>5 720 91 | <ul style="list-style-type: none"> <li>○ White</li> <li>● Aluminium</li> <li>● Matt Black</li> <li>● Magnesium</li> <li>● Champagne</li> <li>● Soft Alu</li> </ul> |
| 1    | 0 793 79           |                    |  |
| 1    | 0 795 79L          |                    |  |
| 1    |                    | 5 725 91           |  |
| 1    |                    | 5 725 59           |  |
| 1    |                    | 5 725 55           |  |
| 1    | 0 787 64           | 5 722 74           | <b>Screw-type sockets - 1 module</b>   |
| 1    | 0 795 64L          |                    | <ul style="list-style-type: none"> <li>○ White</li> <li>● Matt Black</li> <li>● Magnesium</li> <li>● Champagne</li> <li>● Soft Alu</li> </ul>                      |
| 1    |                    | 5 727 74           |  |
| 1    |                    | 5 724 91           |  |
| 1    |                    | 5 724 90           |  |
| 1    | 0 787 73           | 5 722 78           | <b>Solder-type sockets - 1 module</b>  |
|      |                    |                    | <ul style="list-style-type: none"> <li>○ White</li> </ul>  |

| Pack | Cat.Nos            |                    | 2 female RCA sockets  |
|------|--------------------|--------------------|---|
|      |                    |                    | Provide the stereo audio link for any peripheral device such as a DVD player, camera, video recorder, etc               |
|      |                    |                    | 1 module  |
|      |                    |                    | <b>Preterminated</b>  |
|      |                    |                    | Equipped with a 15 cm cord and 2 female connectors  |
| 1    | Mosaic<br>0 787 47 | Arteor<br>5 720 92 | <ul style="list-style-type: none"> <li>○ White</li> <li>● Magnesium</li> <li>● Champagne</li> <li>● Soft Alu</li> </ul> |
| 1    |                    | 5 725 92           |   |
| 1    |                    | 5 724 79           |   |
| 1    |                    | 5 724 75           |   |
| 1    | 0 787 53           | 5 722 72           | <b>Connection via screw terminals</b>   |
| 1    |                    | 5 727 72           | <ul style="list-style-type: none"> <li>○ White</li> <li>● Magnesium</li> <li>● Champagne</li> <li>● Soft Alu</li> </ul> |
| 1    |                    | 5 724 95           |   |
| 1    |                    | 5 724 94           |   |

| Pack | Cat.Nos            |                    | 3 female RCA sockets  |
|------|--------------------|--------------------|---|
|      |                    |                    | Provide the stereo audio link and composite video for any peripheral device such as a DVD player, camera, video recorder, videoconferencing, etc. |
|      |                    |                    | 1 module  |
|      |                    |                    | <b>Connection via screw terminals</b>   |
| 1    | Mosaic<br>0 787 54 | Arteor<br>5 722 73 | <ul style="list-style-type: none"> <li>○ White</li> <li>● Aluminium</li> <li>● Magnesium</li> <li>● Champagne</li> <li>● Soft Alu</li> </ul>      |
| 1    | 0 792 54           |                    |   |
| 1    |                    | 5 727 73           |   |
| 1    |                    | 5 724 97           |   |
| 1    |                    | 5 724 96           |   |

| Pack | Cat.Nos            |                    | 3-pole XLR sockets   |
|------|--------------------|--------------------|--|
|      |                    |                    | Provide the stereo link for any peripheral device, microphone, amplifier, mixing console, etc  |
|      |                    |                    | Recommended cable: 1 shielded audio pair 0.14 mm <sup>2</sup> to 0.50 mm <sup>2</sup>  |
|      |                    |                    | Max. cable length: 50 m (without amplifier)  |
|      |                    |                    | Fast screw connection  |
|      |                    |                    | 2 modules  |
|      |                    |                    | <b>Female sockets</b>  |
| 1    | Mosaic<br>0 787 55 | Arteor<br>5 722 83 | <ul style="list-style-type: none"> <li>○ White</li> <li>● Aluminium</li> <li>● Matt Black</li> <li>● Magnesium</li> <li>● Champagne</li> <li>● Soft Alu</li> </ul> |
| 1    | 0 792 55           |                    |  |
| 1    | 0 795 55L          |                    |  |
| 1    |                    | 5 727 83           |  |
| 1    |                    | 5 724 99           |  |
| 1    |                    | 5 724 98           |  |
| 1    | 0 787 56           | 5 722 77           | <b>Male sockets</b>  |
|      |                    |                    | <ul style="list-style-type: none"> <li>○ White</li> </ul>  |

| Pack | Cat.Nos            |  | Speakon socket - 4 contacts                               |
|------|--------------------|--|---|
|      |                    |  | To be used to connect powered speakers                    |
|      |                    |  | Recommended cable: 2 audio pairs 4 mm <sup>2</sup> max.   |
|      |                    |  | Max. cable length: 50 m (without amplifier)               |
|      |                    |  | 2 modules   |
| 1    | Mosaic<br>0 787 60 |  | <ul style="list-style-type: none"> <li>○ White</li> </ul> |

| Pack | Cat.Nos            |                    | Loudspeaker sockets  |
|------|--------------------|--------------------|--|
|      |                    |                    | For loudspeaker stereo audio link  |
|      |                    |                    | 4 mm <sup>2</sup> terminal   |
|      |                    |                    | <b>Sockets - 1 module</b>  |
| 10   | Mosaic<br>0 787 50 | Arteor<br>5 722 70 | <ul style="list-style-type: none"> <li>○ White</li> <li>● Aluminium</li> <li>● Matt Black</li> <li>● Magnesium</li> <li>● Champagne</li> <li>● Soft Alu</li> </ul> |
| 10   | 0 792 50           |                    |  |
| 10   | 0 795 50L          |                    |  |
| 10   |                    | 5 727 70           |  |
| 10   |                    | 5 726 97           |  |
| 10   |                    | 5 726 96           |  |
| 10   | 0 787 51           | 5 722 80           |  |
| 10   | 0 795 51L          |                    |  |
| 10   |                    | 5 727 80           |  |
| 10   |                    | 5 726 99           |  |
| 10   |                    | 5 726 98           |  |

| Pack | Cat.Nos            |                    | 100 V line attenuators   |
|------|--------------------|--------------------|--|
|      |                    |                    | 25 W - 2 modules   |
|      |                    |                    | To be used to control the power from a 100 V PA system line                    |
| 1    | Mosaic<br>0 787 76 | Arteor<br>5 722 84 | <ul style="list-style-type: none"> <li>○ White</li> <li>● Magnesium</li> </ul> |
| 1    |                    | 5 727 84           |  |

| Pack | Cat.Nos            |                    | Female BNC 75 sockets - 1 module  |
|------|--------------------|--------------------|---|
|      |                    |                    | Provide the composite video link for any peripheral device such as a DVD player, camera, video recorder, etc. |
| 1    | Mosaic<br>0 787 58 | Arteor<br>5 722 76 | <ul style="list-style-type: none"> <li>○ White</li> <li>● Magnesium</li> </ul>                                |
| 1    |                    | 5 727 76           |   |



## Audio/video system

### HDMI cords and adaptors, HD15 cords and audio cords



0 517 33



0 517 27



0 514 03

| Pack | Cat.Nos                 |                                   | HDMI cords, booster and adaptors   |
|------|-------------------------|-----------------------------------|--|
|      |                         |                                   | <b>High Speed HDMI® cords with Ethernet</b><br>For connecting an HDMI socket to the audiovideo terminal (TV, DVD or Blu-Ray player, Home Cinema, games console, etc)<br>HDMI 2.0 cords<br>Support 4K and 1080P video resolution<br>Gold-plated connectors  |
| 1    | Plastic bag<br>0 517 32 | Plastic bag with hook<br>0 398 51 | Length 1 m   |
| 1    | 0 517 33                | 0 398 52                          | Length 2 m   |
| 1    | 0 517 34                | 0 398 53                          | Length 3 m   |
| 1    | 0 517 27                | 0 398 54                          | Length 5 m   |
| 1    | 0 517 35                | 0 398 55                          | Length 7 m   |
|      |                         |                                   | <b>Standard HDMI® cords with Ethernet</b><br>For connecting an HDMI socket to the audio video terminal (TV, DVD or Blu-Ray player, Home Cinema, games console, etc)<br>HDMI 2.0 cords<br>Support 1080i and 720P video resolution<br>Gold-plated connectors |
| 1    | 0 517 20                |                                   | Length 10 m  |
| 1    | 0 517 36                |                                   | Length 15 m  |
| 1    |                         | 0 398 56                          | <b>HDMI to micro HDMI cord</b><br>Length 2 m   |
| 1    | 0 517 37                | 0 398 57                          | <b>90° HDMI adaptors</b><br>Male HDMI to female HDMI with 90° angle<br>To be used to make a connection when space is limited   |
| 1    | 0 514 00                | 0 398 58                          | <b>Display Port cords</b><br>Length 2 m<br>For connecting a Display Port socket to an audio/video terminal (PC, monitor, etc)  |

| Pack | Cat.Nos                 |                                   | HD15 cords   |
|------|-------------------------|-----------------------------------|--|
|      |                         |                                   | <b>Male/male HD15 cords</b><br>For connecting an HD15 socket to a video terminal (PC, video projector, etc)<br>Support QXGA resolution (2048x1536) |
| 1    | Plastic bag<br>0 517 29 | Plastic bag with hook<br>0 398 50 | Length 2 m   |
| 1    | 0 517 30                |                                   | Length 5 m   |
| 1    | 0 517 23                |                                   | Length 10 m  |
| 1    | 0 517 31                |                                   | Length 15 m  |
| 1    | 0 517 22                |                                   | <b>HD15 cord + 3.5 mm Jack</b><br>Length 2 m<br>For connecting an HD15 video socket and a 3.5 mm audio jack to a terminal (PC, video projector)    |
|      |                         |                                   | <b>Audio cords</b>   |
|      |                         |                                   | <b>RCA male/male stereo audio cords</b>  |
| 1    | Plastic bag<br>0 514 03 | Plastic bag with hook<br>0 398 67 | Length 2 m   |
| 1    | 0 514 04                | 0 398 68                          | Length 5 m   |
| 1    | 0 514 05                | 0 398 69                          | <b>Jack 3.5 mm male to 2 RCA male Y audio cords</b><br>Length 2 m  |
| 1    | 0 514 06                | 0 398 70                          | Length 5 m   |
| 1    | 0 514 07                | 0 398 71                          | <b>Jack 3.5 mm male / male audio cords</b><br>Length 2 m   |
| 1    | 0 514 08                | 0 398 72                          | Length 5 m   |
| 1    |                         | 0 398 73                          | <b>TOSLINK optical digital cable</b><br>Length 2 m   |

HDMI extender  
p. 145



## Audio/video system

### USB Type-C adaptors and cords, data cords and cables



| Pack | Cat.Nos                 |                                   |   |
|------|-------------------------|-----------------------------------|---|
| 1    | Plastic bag<br>0 514 12 | Plastic bag with hook<br>0 398 66 | <b>USB Type-C adaptors</b><br><b>Male USB 3.1 Type-C/female HDMI adaptors</b><br>For connecting a USB Type-C device to the HDMI port of a video projector or TV set to play audio and video |
| 1    | Plastic bag<br>0 514 10 | Plastic bag with hook<br>0 398 63 | <b>USB 3.1 Type-C cords</b><br><b>Male USB 3.1 Type-C/male Type-C cord - length 1 m</b><br>To be used to load, transfer data and play audio/video   |
|      | Plastic bag             | Plastic bag with hook             | <b>USB data cords</b><br>To be used to transfer data between a USB Data socket and a peripheral (hard disk, printer, scanner, etc)  |
| 1    |                         | 0 398 61                          | <b>Length 1 m</b><br>Male USB 2.0 A/male Micro B cord   |
| 1    |                         | 0 398 62                          | Male USB 3.0 A/male Lightning cord  |
| 1    |                         | 0 398 65                          | Male USB 2.0 Type-C/male micro B USB cord   |
|      |                         |                                   | <b>Length 2 m</b>   |
| 1    | 0 514 01                | 0 398 59                          | Male USB 3.0 A/male A cord  |
| 1    | 0 514 02                | 0 398 60                          | Male USB 3.0 A/male B cord  |
| 1    | 0 514 11                | 0 398 64                          | Male USB 2.0 Type-C/male USB-A cord   |
|      | Plastic bag with hook   |                                   | <b>Cat. 6 U/UTP RJ 45 cords</b>   |
| 1    |                         | 0 398 74                          | RJ 45 - RJ 45 flat<br>Length 2 m  |
| 1    |                         | 0 398 75                          | Length 5 m  |
| 1    |                         | 0 398 76                          | Length 10 m   |
| 1    |                         | 0 398 77                          | Length 15 m   |
| 1    |                         | 0 398 78                          | Length 20 m   |
| 1    |                         | 0 398 79                          | Length 30 m   |
|      |                         |                                   | <b>Cables</b>   |
| 1    |                         | 0 327 81                          | <b>VGA cable</b><br>Length 20 m<br>For full pin connection of HD15 sockets at a distance of up to 15 m  |
| 1    |                         | 0 514 09                          | <b>Loudspeaker cable</b><br>Length 15 m<br>For connecting an amplifier and speakers   |

## Audio/video system

### USB Data and SUB D data sockets



| Pack | Cat.Nos            |                    |  |
|------|--------------------|--------------------|--|
|      |                    |                    | <b>Female USB Data sockets</b><br>For connecting USB devices (printer, scanner, external hard drive, interactive panel)<br>1 module  |
|      |                    |                    | <b>Preterminated - USB 2.0</b><br>Max. cable length: 5 m<br>Recommended cable: USB A<br>Equipped with cable length 15 cm   |
| 1    | Mosaic<br>0 787 46 | Arteor<br>5 720 94 | ○ White  |
| 1    |                    | 5 725 94           | ● Magnesium  |
| 1    |                    | 5 725 76           | ● Champagne  |
| 1    |                    | 5 725 75           | ● Soft Alu   |
|      |                    |                    | <b>Screw-type - USB 2.0</b><br>Max. cable length: 5 m<br>Recommended cable: USB A<br>Connection using screw terminal blocks with 1 mm <sup>2</sup> cross-section   |
| 1    | 0 787 61           | 5 722 75           | ○ White  |
| 1    |                    | 5 727 75           | ● Magnesium  |
| 1    |                    | 5 725 53           | ● Champagne  |
| 1    |                    | 5 725 52           | ● Soft Alu   |
|      |                    |                    | <b>Female USB Data Type-A extender - for data transfer</b>   |
| 1    | Mosaic<br>0 787 48 | Arteor<br>5 720 23 | ○ White<br>For connecting a USB peripheral (keyboard, mouse, digital control panel, etc) to a source (computer) located more than 5 m away (up to 30 m)<br>The kit contains a transmitter (1 module) and a receiver (1 module)<br>The transmitter and receiver are linked by an RJ 45/RJ 45 cable (not supplied) |
|      |                    |                    |  |
|      |                    |                    | <b>SUB D socket</b>  |
| 1    | Mosaic<br>0 787 65 |                    | ○ White<br>2 modules<br>9 contacts with screw-type connector for RS 232 serial link  |



## Legrand cabling system LCS<sup>3</sup> enclosures

### server cabinets



4 464 07



4 464 17

Colour: Black RAL 9005  
 Frame: aluminium, demountable  
 Load capacity: 1500 kg (static)  
 80 % perforated front door and 80 % perforated double rear doors: all doors are fitted with a Fix-easy swivel handle with a EK333 locking  
 Roof: 3 cut-outs (the left and right ones have blindplates and brushes, the center one has a blind plate)  
 Interior: cabinet equipped with 4 x 19" profiles including height (U) indication  
 Distance to the cabinet with airflow front: set to 80 mm (pitch set to 100 mm)  
 Distance to the cabinet front: set to 175 mm (pitch set to 100 mm)  
 Server cabinets supplied without side panels. Flatpack server cabinets supplied with side panels  
 Server cabinets with airflow management are supplied with an airflow management package keeping the loss of air to a minimum, thus improving energy efficiency  
 Cabinets equipped with leveling feet  
 Server cabinets with airflow management are supplied with a sideskirt with cut-outs and blind panels

#### LCS<sup>3</sup> 19" server cabinets

| Pack | Cat.Nos  | Capacity | Width (mm) | Depth (mm) |
|------|----------|----------|------------|------------|
| 1    | 4 464 00 | 42 U     | 600        | 1000       |
| 1    | 4 464 01 | 42 U     | 600        | 1200       |
| 1    | 4 464 02 | 42 U     | 800        | 1000       |
| 1    | 4 464 03 | 42 U     | 800        | 1200       |
| 1    | 4 464 04 | 47 U     | 600        | 1000       |
| 1    | 4 464 05 | 47 U     | 600        | 1200       |
| 1    | 4 464 06 | 47 U     | 800        | 1000       |
| 1    | 4 464 07 | 47 U     | 800        | 1200       |

#### LCS<sup>3</sup> 19" server cabinets with air flow management

| Pack | Cat.Nos  | Capacity | Width (mm) | Depth (mm) |
|------|----------|----------|------------|------------|
| 1    | 4 464 10 | 42 U     | 600        | 1000       |
| 1    | 4 464 11 | 42 U     | 600        | 1200       |
| 1    | 4 464 12 | 42 U     | 800        | 1000       |
| 1    | 4 464 13 | 42 U     | 800        | 1200       |
| 1    | 4 464 14 | 47 U     | 600        | 1000       |
| 1    | 4 464 15 | 47 U     | 600        | 1200       |
| 1    | 4 464 16 | 47 U     | 800        | 1000       |
| 1    | 4 464 17 | 47 U     | 800        | 1200       |

#### Side panels for server cabinets

Set of 2, with plinths

| Pack | Cat.Nos  | Capacity | Depth (mm) |
|------|----------|----------|------------|
| 2    | 4 464 20 | 42 U     | 1000       |
| 2    | 4 464 21 | 42 U     | 1200       |
| 2    | 4 464 22 | 47 U     | 1000       |
| 2    | 4 464 23 | 47 U     | 1200       |

#### LCS<sup>3</sup> Flatpack server cabinets, including side panels

Flatpack cabinets have the same configuration as Cat.Nos 4 464 02 and 4 464 03 respectively, only with side panels

| Pack | Cat.Nos  | Capacity | Width (mm) | Depth (mm) |
|------|----------|----------|------------|------------|
| 1    | 4 464 25 | 42 U     | 800        | 1000       |
| 1    | 4 464 26 | 42 U     | 800        | 1200       |

## Legrand cabling system LCS<sup>3</sup> enclosures

### cabling cabinets



4 464 34

Colour: Black RAL 9005  
 Frame: aluminium, demountable  
 Load capacity: 1500 kg (static)  
 Glass front door and blind steel door in the back: all doors are fitted with a Fix-easy swivel handle with a EK333 locking  
 Roof: 3 cut-outs (the left and right ones have blindplates and brushes, the center one has a blind plate)  
 Interior: cabinet equipped with 4 x 19" profiles including height (U) indication  
 Distance to the cabinet front: set to 175 mm (pitch set to 100 mm)  
 Cabinets delivered with side panels  
 Cabinets equipped with leveling feet

#### LCS<sup>3</sup> 19" cabling cabinets - 800 mm wide

| Pack | Cat.Nos  | Capacity | Width (mm) | Depth (mm) | Height (in mm) |
|------|----------|----------|------------|------------|----------------|
| 1    | 4 464 30 | 24 U     | 800        | 800        | 1300           |
| 1    | 4 464 31 | 24 U     | 800        | 1000       | 1300           |
| 1    | 4 464 32 | 42 U     | 800        | 800        | 2000           |
| 1    | 4 464 33 | 42 U     | 800        | 1000       | 2000           |
| 1    | 4 464 34 | 47 U     | 800        | 800        | 2200           |
| 1    | 4 464 35 | 47 U     | 800        | 1000       | 2200           |

# Legrand cabling system LCS<sup>3</sup> enclosures

accessories for server cabinets and cabling cabinets



4 464 94

4 464 99



4 464 78

4 464 80

4 464 82 (mounted on height profile)



4 464 75



4 464 63



4 464 62



4 464 72

| Pack | Cat.Nos  | Accessories for airflow management  |
|------|----------|---|
| 25   | 4 464 94 | <b>Front panels</b><br>1U front panels (set of 25). Plastic<br>To be mounted in between the 19" profiles. No tools needed to secure the panel               |
| 1    | 4 464 75 | <b>Sideskirt brush</b><br>Sideskirt brush, depth 200 mm   |
|      |          | <b>Plinths</b><br>Front-rear sheet metal plinths to be added in order to increase the level of airtightness<br>To be associated with leveling feet<br>Black |
| 1    | 4 464 99 | Width 600 mm. Height 0-25 mm  |
| 1    | 4 464 59 | Width 800 mm. Height 0-25 mm  |
| 1    | 4 464 57 | Width 600 mm. Height 22-47 mm   |
| 1    | 4 464 58 | Width 800 mm. Height 22-47 mm   |

| Pack | Cat.Nos  | Accessories for cable management   |
|------|----------|--|
|      |          | <b>Cable trays</b><br>Powdercoated cable trays, width 200 mm<br>Black  |
| 1    | 4 464 63 | Height: 24U  |
| 1    | 4 464 64 | Height: 42U  |
| 1    | 4 464 65 | Height: 47U  |
|      |          | <b>Wiremesh cable trays</b><br>Zinc-blue passivated wiremesh cable trays, width 200 mm   |
| 1    | 4 464 62 | Height: 24U  |
| 1    | 4 464 60 | Height: 42U  |
| 1    | 4 464 61 | Height: 47U  |
|      |          | <b>Strips</b><br>U-shaped sheet metal strips for toolless mounting of cable management accessories in front of VMRs<br>Black   |
| 1    | 4 464 70 | Height: 24U  |
| 1    | 4 464 71 | Height: 42U  |
| 1    | 4 464 72 | Height: 47U  |
|      |          | <b>Cable guides</b><br>To be mounted on vertical cable management profiles that attach to the VMRs<br>Include a snap-on feature enabling the installation of bend radius cover Cat.No 4 464 76 |
| 1    | 4 464 91 | Height: 24U  |
| 1    | 4 464 92 | Height: 42U  |
| 1    | 4 464 93 | Height: 47U  |
| 1    | 4 464 76 | Bend radius cover<br>To be installed (no tools required) on cable guides<br>Cat.Nos 4 464 91/92/93   |
|      |          | <b>Cable rings</b><br>Set of 10 cable rings to be mounted on cable trays or vertical cable management profiles<br>Black  |
| 10   | 4 464 77 | Cable ring   |
| 10   | 4 464 78 | Cable ring with brackets   |
|      |          | <b>Tying brackets</b><br>Set of 10 pull and relief brackets<br>For mounting on frames (top or bottom)  |
| 10   | 4 464 79 | For mounting on frames (top or bottom)   |
| 10   | 4 464 80 | For mounting on roof   |
|      |          | <b>Steel cable rings</b><br>Set of 10 cable rings, for assembling cable bundles<br>Zinc - Hot Dip  |
| 10   | 4 464 82 | To be mounted on cable trays and height profiles<br>Width 100 mm. Depth 80 mm  |
| 10   | 4 464 81 | To be mounted on height profiles<br>Width 85 mm. Depth 165 mm  |
| 10   | 4 464 83 | To be mounted on VMRs<br>Width 85 mm. Depth 165 mm   |



## Legrand cabling system LCS<sup>3</sup> enclosures

### accessories for server cabinets and cabling cabinets (continued)

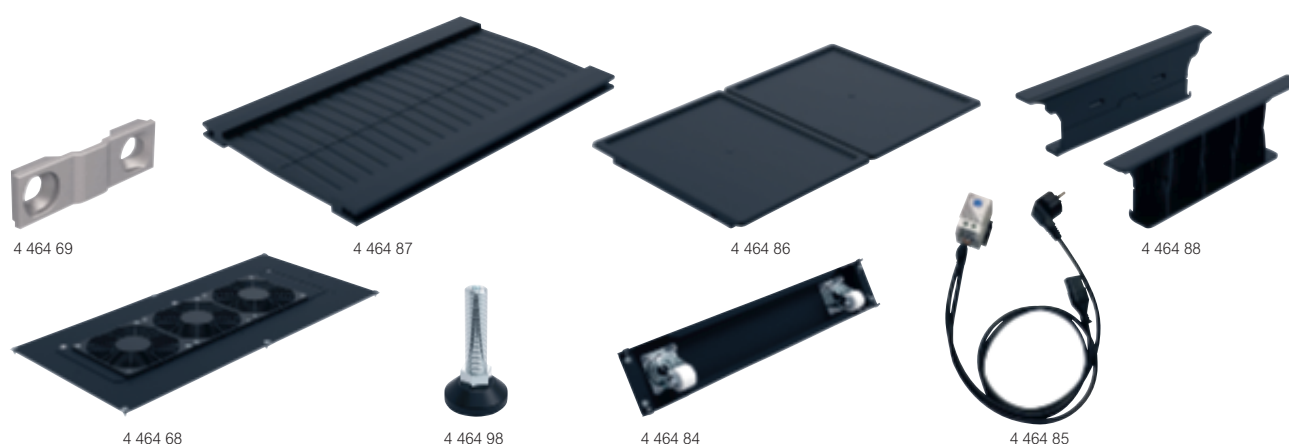

| Pack | Cat.Nos  | Mechanical accessories  |
|------|----------|---|
| 6    | 4 464 69 | <b>Frame couplers</b><br>Set of 6 frame couplers<br>To be used to connect two cabinets  |
| 1    | 4 464 87 | <b>Roof brushes</b><br>Roof brush to be installed on right/left roof cut-outs<br>Depth 200 mm   |
| 1    | 4 464 95 | Roof brush to be installed on middle roof plates<br>(the roof layout must include a cut-out in the middle plate) Black  |
| 1    | 4 464 86 | <b>Plastic blind plate</b><br>Plastic blind plate, depth 200 mm<br>To be installed on right/left roof cut-outs to completely cover gaps   |
| 2    | 4 464 88 | <b>Roof inserts - cable guides</b><br>Cable guide, set of 2<br>To be installed on right/left roof cut-outs to facilitate the management of top-of-cabinet cables  |
| 2    | 4 464 89 | Cable guide end plate, set of 2<br>To be installed on right/left roof cut-outs to facilitate the management of top-of-cabinet cables  |
| 1    | 4 464 90 | Cable guide set, 100 mm<br>To be installed on right/left roof cut-outs to facilitate the management of top-of-cabinet cables  |
| 1    | 4 464 96 | Roof middle cable guide, black<br>To be installed on middle roof plates (the roof layout must include a cut-out in the middle plate)  |
| 1    | 4 464 68 | <b>Roof fan unit</b><br>Roof fan unit - black<br>Comprises 3 axial fans<br>Flow with no load: 480 m <sup>3</sup> /h<br>Flow under normal loads: over 300 m <sup>3</sup> /h<br>To be connected using IEC-320 C13 connectors<br>Can be combined using a cable with IEC-320 C13 / C14 connectors |
| 4    | 4 464 98 | <b>Adjustable base legs</b><br>Set of 4, height 61 mm   |
| 2    | 4 464 97 | Set of 2, height 61 mm<br>To be used with cabinets equipped with light duty casters   |
| 4    | 4 464 84 | <b>Casters</b><br>Light duty casters (set of 4 wheels)<br>Maximum dynamic load: 200 kg<br>Black   |
| 1    | 4 464 85 | <b>Temperature management</b><br>Thermostat, to be used to ensure the fan switches on at a selected temperature   |

| Pack | Cat.Nos  | Accessories for PDUs  |
|------|----------|---|
|      |          | <b>Frames</b><br>Set of 2 PDU brackets  |
| 2    | 4 464 73 | 1-fold  |
| 2    | 4 464 74 | 2-fold  |
|      |          | <b>Cable trays</b><br>Powdercoated PDU cable trays to be used for installing PDUs or for vertical cable management<br>Width 170 mm: allows installation of up to three 1U PDUs, 2 intelligent PDUs or 1 High-Density PDU<br>Cables can be attached to the tray using tie-wraps and/or Velcro<br>Black |
| 1    | 4 464 66 | Height: 42U   |
| 1    | 4 464 67 | Height: 47U   |

## Legrand cabling system LCS<sup>3</sup> enclosures

### wall-mounting cabinets

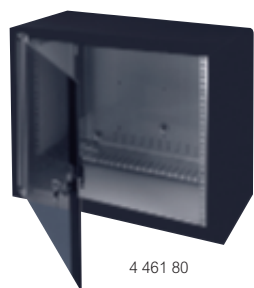

4 461 80



4 461 90



4 461 91



6 466 69

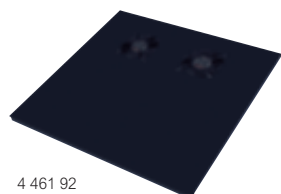

4 461 92



4 461 95

| Pack | Cat.Nos  | <b>Wall-mounting cabinets with glass door</b>   |            |            |             |
|------|----------|---|------------|------------|-------------|
|      |          | <p>Comprise:</p> <ul style="list-style-type: none"> <li>- a wall element with integrated strain relief profile</li> <li>- 4 front and rear bars</li> <li>- 2 cable entry plates (top and bottom)</li> <li>- a set of two 19" profiles with adjustable depth (in steps of 50 mm) and a pattern of holes on the side allowing accessories to be fitted. The casing consists of two identical upper and lower panels with ventilation slots at the rear, two identical side panels and a Securit glass door with an EK-333 lock and a handle. Possibility to adjust the cable holes' size on the spot thanks to the handy bend-away fingers</li> </ul> <p>Width: 600 mm<br/>Colour: RAL 9011<br/>Finish: powder coating<br/>Max. load: 100 kg<br/>Supplied with 1 rear plate, 4 depthwise bars, 2 cable entry plates, 2 x 19" profiles, 2 roof and floor plates, 2 side panels, 1 glass door, 1 assembly set, including assembly guide</p> |            |            |             |
|      |          | Capacity  | Width (mm) | Depth (mm) | Height (mm) |
| 1    | 4 461 80 | 6 U   | 600        | 525        | 342         |
| 1    | 4 461 81 | 9 U   | 600        | 525        | 476         |
| 1    | 4 461 82 | 9 U   | 600        | 625        | 476         |
| 1    | 4 461 83 | 12 U  | 600        | 525        | 609         |
| 1    | 4 461 84 | 12 U  | 600        | 625        | 609         |
| 1    | 4 461 85 | 15 U  | 600        | 525        | 742         |
| 1    | 4 461 86 | 15 U  | 600        | 625        | 742         |
| 1    | 4 461 87 | 21 U  | 600        | 625        | 1009        |

| Pack | Cat.Nos  | <b>Accessories</b>  |  |
|------|----------|---|--|
| 1    | 4 461 90 | <p><b>Cable entry strip for wall-mounting cabinet</b><br/>For dust-free cable entry. To be used in replacement of a top and/or bottom cable entry plate<br/>Supplied with 1 cable entry brush (360 mm), including fastenings</p>  |  |
| 1    | 4 461 91 | <p><b>Corner guide set</b><br/>Comprises 2 corner guide supports (left and right) and fastening materials<br/>To be fitted specifically to the sides of the 19" profiles<br/>Supports heavy 19" equipment<br/>Suitable for a wall-mounting cabinet<br/>Material: galvanized sheet steel</p>   |  |
|      |          | <p><b>Roof plates with built-in fan unit</b><br/>Can be added as an option to generate a forced cooling air flow in the wall-mounting cabinet<br/>Replace an existing roof panel<br/>Can be used in conjunction with thermostat<br/>Cat.Nos 4 460 98<br/>Supplied with assembly materials</p> |  |
| 1    | 4 461 92 | Depth: 525 mm   |  |
| 1    | 4 461 93 | Depth: 625 mm   |  |

## Legrand cabling system LCS<sup>3</sup> enclosures

### accessories for wall-mounting cabinets

| Pack | Cat.Nos  | <b>LCS<sup>3</sup> accessories</b>  |  |
|------|----------|---|--|
| 1    | 4 460 98 | Thermostat  |  |
| 1    | 6 466 68 | Horizontal cable ring   |  |
| 1    | 6 466 69 | Vertical cable ring   |  |
|      |          | <p><b>19" profiles</b><br/>Can be used when equipment shelves need to be installed (with fixings at front and rear)<br/>Supplied in sets of 2</p> |  |
| 1    | 4 461 95 | Height: 6 U   |  |
| 1    | 4 461 96 | Height: 9 U   |  |
| 1    | 4 461 97 | Height: 12 U  |  |
| 1    | 4 461 98 | Height: 15 U  |  |
| 1    | 4 461 99 | Height: 21 U  |  |
|      |          | <p><b>Glass doors</b><br/>Width: 600 mm</p>   |  |
| 1    | 9 004 73 | 6 U glass door  |  |
| 1    | 9 004 74 | 9 U glass door  |  |
| 1    | 9 004 75 | 12 U glass door   |  |
| 1    | 9 004 76 | 15 U glass door   |  |
| 1    | 9 004 77 | 21 U glass door   |  |

# Legrand cabling system LCS<sup>3</sup> enclosures

## 19" accessories



| Pack | Cat.Nos  | 19" cable feedthrough panels   |
|------|----------|--|
|      |          | For organising and running patch cords. Black RAL 9005   |
|      |          | <b>Metal, 2 axes, Quick-Fix</b><br>Horizontal feedthrough passage. With cable rings plastic cable guide with controlled radius for optimum cord protection (compliance with the bending radius)<br>Quick installation without screws |
| 1    | 0 465 22 | 1 U  |
| 1    | 0 465 23 | 2 U  |
|      |          | <b>Plastic with brush, snap on</b>   |
| 1    | 0 465 28 | 1 U  |
| 1    | 0 465 29 | 2 U  |
|      |          | <b>Metal with brush, Soluclip</b><br>Quick installation without screws   |
| 1    | 0 465 30 | 1 U  |
| 1    | 0 465 31 | 2 U  |

| Pack | Cat.Nos  | 19" blanking plates  |
|------|----------|--|
|      |          | Black RAL 9005   |
|      |          | <b>Plastic, direct clipping</b>                              |
| 1    | 0 465 32 | 1 U  |
| 1    | 0 465 33 | 2 U  |
|      |          | <b>Metal, Quick-Fix</b><br>Quick installation without screws |
| 1    | 0 465 38 | 1 U  |
| 1    | 0 465 39 | 2 U  |
| 1    | 0 465 40 | 3 U  |

| Pack | Cat.Nos  | LED Lighting  |
|------|----------|---|
|      |          | Prewired with 2 m length power cord<br>Magnets fastening<br>With switch<br>60° swivel |
| 1    | 0 464 91 |   |
|      |          | With presence sensor<br>120° swivel   |
| 1    | 0 363 81 |   |

# Legrand cabling system LCS<sup>3</sup> enclosures

## cabling openrack and accessories



| Pack  | Cat.Nos  | Cabling openrack and accessories   |
|-------|----------|--|
| 1     | 4 461 50 | Punched hole channel rack, 2130 mm x 609 mm (7 ft x 24"), black, square hole 9 mm (3/8") |
| 1     | 4 461 52 | Cable duct with door   |
| 6     | 4 461 54 | Hexagonal cable feedthroughs (set of 6)  |
| 12    | 4 461 55 | Bend limiting clips (set of 12)  |
| 4     | 4 461 56 | Cable management spools (set of 4)   |
| 1     | 4 461 57 | Cable management rings   |
| 1     | 4 461 58 | Cable duct mounting brackets (top of rack Cablofil)                                      |
| 1     | 4 461 60 | Overhead cable tray, 5 U, 19"  |
| 1     | 4 461 59 | Horizontal cable management system   |
| 1     | 0 465 70 | 19" closed panel for cord management with pivoting cover - 1U - black - depth 172 mm     |
| 1     | 0 465 71 | 19" closed panel for cord management with pivoting cover - 2U - black - depth 172 mm     |
| 50/25 | 0 464 23 | Set of 50 special screws for racks + 25 earthing claws                                   |

# Innovation at the heart of PDUs to prevent accidental disconnection

A major addition to the range and exclusive to Legrand, C13 and C19 outlets have a power supply cord locking system which prevents accidental disconnection and guarantees absolute safety!



An innovative technical solution: very easy to identify thanks to the orange buttons next to each socket.



A universal system: takes all cords for standard C13 and C19 outlets.

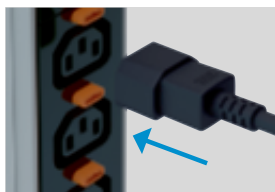
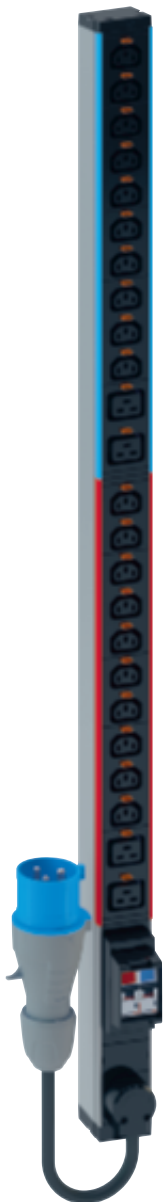

CONNECTION

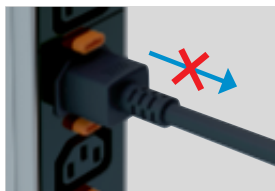

AUTO LOCKING

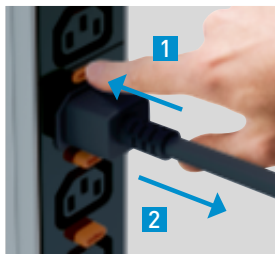

UNLOCKING

## Legrand cabling system LCS<sup>3</sup> energy distribution - single-phase Zero-U Basic PDUs

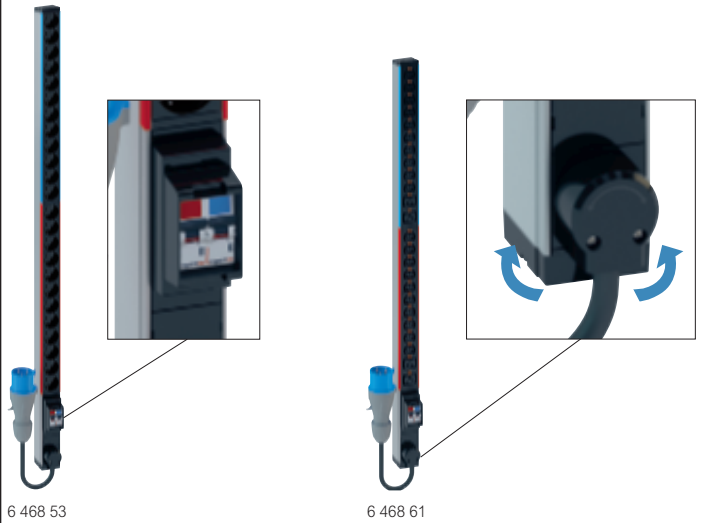

To provide ~ electric power for IT equipment in 19" enclosures Single phase Zero-U PDUs for vertical mounting in the cabinet 230 V - 50/60 Hz power supply PDUs with 2 circuits protected by 16 A uni + neutral MCB (except Cat.Nos 6 469 00/01/02 with 1 circuit) in a support with projecting edges to avoid accidental breakdown. Each circuit is identified by color coding. The total number of outlets is distributed equally between the 2 circuits. 2P+E outlets: C13 and C19 standard outlets, French/German/British standards outlets equipped with safety shutters, French/German standards outlets inclined at 55° 330° rotating cable input for a perfect orientation of the cable and no interference in the cabinet C13 and C19 standard outlets are equipped with cord locking system to avoid any accidental disconnection. Universal solution compatible with all the cords (C14 plugs for C13 and C20 plugs for C19) Delivered with 2 sets of metallic mounting brackets: button brackets (for quick fixing and variable pitch) and standard brackets (for screw fixing) Black modules (outlets and functions) Aluminium profile

| Pack | Cat.Nos  | PDU Basic  |
|------|----------|--|
| 1    | 6 468 52 | <b>German standard</b><br>24 outlets<br>Connection on terminal block up to 6 mm <sup>2</sup>   |
| 1    | 6 468 53 | 24 outlets<br>3 m power supply cord with IEC 60309 32 A 2P+E plug  |
| 1    | 6 469 00 | 12 outlets<br>With surge protection<br>3 m power supply cord with 16 A French/German 2P+E plug   |
| 1    | 6 469 01 | 14 outlets<br>With power indicator<br>3 m power supply cord with 16 A French/German 2P+E plug  |
| 1    | 6 468 54 | <b>British standard</b><br>24 outlets<br>Connection on terminal block up to 6 mm <sup>2</sup>  |
| 1    | 6 468 50 | <b>French standard</b><br>24 outlets<br>Connection on terminal block up to 6 mm <sup>2</sup>   |
| 1    | 6 468 51 | 24 outlets<br>3 m power supply cord with IEC 60309 32 A 2P+E plug  |
| 1    | 6 468 59 | <b>Italian standard</b><br>24 outlets<br>3 m power supply cord with IEC 60309 32 A 2P+E plug   |
| 1    | 6 468 56 |  <b>IEC 60320 standard</b><br>24 C13 outlets with cord locking system<br>Connection on terminal block up to 6 mm <sup>2</sup> |
| 1    | 6 468 57 | 24 C13 outlets with cord locking system<br>3 m power supply cord with IEC 60309 32 A 2P+E plug   |
| 1    | 6 469 02 | 24 C13 outlets + 12 C19 outlets with cord locking system. With 1 power indicator module per phase.<br>3 m power supply cord with IEC 60309 32 A 3P+N+E plug  |
| 1    | 6 468 60 | 20 C13 outlets + 4 C19 outlets with cord locking system. Connection on terminal block up to 6 mm <sup>2</sup>  |
| 1    | 6 468 61 | 20 C13 outlets + 4 C19 outlets with cord locking system. 3 m power supply cord with IEC 60309 32 A 2P+E plug   |

## Legrand cabling system LCS<sup>3</sup> energy distribution - three-phase Zero-U Basic PDU



To provide ~ electric power for IT equipment in 19" enclosures  
 Three phases Zero-U PDU for vertical mounting in the cabinet  
 400 V - 50/60 Hz power supply  
 Each circuit is protected by 16 A single pole MCB in a support with projecting edges to avoid accidental breakdown. 1 circuit per phase, each with 6 IEC 60320 C13 outlets and 2 IEC 60320 C19 outlets  
 330° rotating cable input for a perfect orientation of the cable and no interference in the cabinet  
 C13 and C19 standard outlets are equipped with cord locking system to avoid any accidental disconnection. Universal solution compatible with all the cords (C14 plugs for C13 and C20 plugs for C19)  
 Delivered with 2 sets of metallic mounting brackets: button brackets (for quick fixing and variable pitch) and standard brackets (for screw fixing)  
 Black modules (outlets and functions)  
 Aluminium profile

| Pack | Cat.Nos  | PDU Basic   |
|------|----------|---|
| 1    | 6 468 70 | <b>IEC 60320 standard</b><br>18 C13 outlets + 6 C19 outlets with cord locking system. 3 m power supply cord with IEC 60309 16 A 3P+N+E plug |

## Legrand cabling system LCS<sup>3</sup> energy distribution - horizontal (1U/2U) Basic PDUs

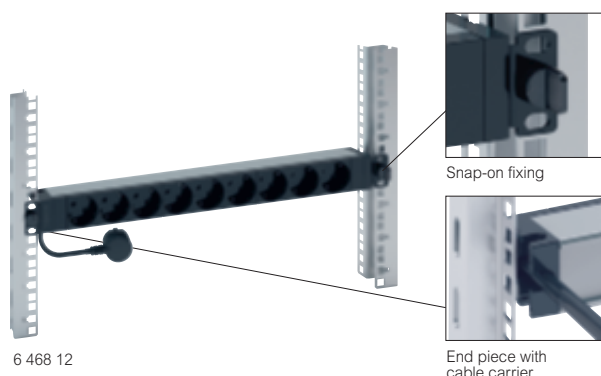

To provide ~ electric power for IT equipment in enclosure. 230 V - 50/60 Hz power supply. 1U aluminium profile. End cap with metallic brackets and cable holder shape. Quick fixing (no screws) on 19" fixing centers. Can also be installed vertically by reverting the brackets (no screws)  
 2P+E outlets:  
 - C13 and C19 standard outlets are equipped with cord locking system to avoid any accidental disconnection. Universal solution compatible with all the cords (C14 plugs for C13 and C20 plugs for C19).  
 - French, German and British standard outlets are equipped with safety shutters  
 - French and German standard outlets are inclined at 55°  
 Black modules (outlets and functions)

| Pack | Cat.Nos  | 19" - PDU Basic   |
|------|----------|---|
| 1    | 6 468 06 | <b>German standard</b><br>3 m power supply cord with 16 A 2P+E French/German plug                             |
| 1    | 6 468 12 | 6 outlets<br>9 outlets  |
| 1    | 6 468 13 | <b>British standard</b><br>3 m power supply cord with 13 A 2P+E British plug<br>8 outlets                     |
| 1    | 6 468 05 | <b>French standard</b><br>3 m power supply cord with 16 A 2P+E French/German plug                             |
| 1    | 6 468 10 | 6 outlets   |
| 1    | 6 468 11 | 9 outlets<br>9 tamperproof red outlets  |
| 1    | 6 468 18 | <b>Swiss standard</b><br>3 m power supply cord with Swiss plug  |
| 1    | 6 468 19 | 12 T13<br>12 T23  |
| 1    | 6 468 14 | <b>IEC 60320 standard</b><br>Connection on terminal block (except Cat.Nos 6 468 15)                           |
| 1    | 6 468 15 | 10 C13 outlets with cord locking system<br>12 C13 outlets with cord locking system                            |
| 1    | 6 468 09 | 3 m power supply cord with IEC 60309 16 A 2P+E plug<br>6 C13 outlets + 2 C19 outlets with cord locking system |
| 1    | 6 468 07 | 6 C19 outlets with cord locking system  |
| 1    | 6 468 01 | <b>10" - PDU Basic</b><br>1 m power supply cord with French/German 2P+E plug                                  |
| 1    | 6 468 00 | <b>4 x 2P+E outlets</b><br>German standard<br>French standard   |

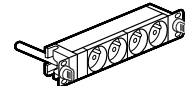

## Legrand cabling system LCS<sup>3</sup> energy distribution - horizontal (1U/2U) Basic PDUs (continued)



6 468 24

To provide ~ electric power for IT equipment in enclosure. 230 V - 50/60 Hz power supply. 1U aluminium profile. End cap with metallic brackets and cable holder shape. Quick fixing (no screws) on 19" fixing centers. Can also be installed vertically by reverting the brackets (no screws)

2P+E outlets:

- C13 and C19 standard outlets are equipped with cord locking system to avoid any accidental disconnection. Universal solution compatible with all the cords (C14 plugs for C13 and C20 plugs for C19).
- French, German and British standard outlets are equipped with safety shutters
- French and German standard outlets are inclined at 55°

Black modules (outlets and functions)

| Pack | Cat.Nos  | 19" - PDU Basic with power indicator or luminous switch   |
|------|----------|---|
|      |          | LED indicator: signals whether the PDU is supplied with power or not<br>LED indicator switch: powers on/off the PDU |
|      |          | <b>German standard</b><br>3 m power supply cord with 16 A 2P+E French/German plug                                   |
| 1    | 6 468 21 | 9 outlets and 1 power indicator   |
| 1    | 6 468 23 | 8 outlets and 1 luminous switch   |
|      |          | <b>British standard</b><br>3 m power supply cord with 13 A 2P+E British plug  |
| 1    | 6 468 24 | 6 outlets and 1 luminous switch   |
|      |          | <b>French standard</b><br>3 m power supply cord with 16 A 2P+E French/German plug                                   |
| 1    | 6 468 20 | 9 outlets and 1 power indicator   |
| 1    | 6 468 22 | 8 outlets and 1 luminous switch   |

## Legrand cabling system LCS<sup>3</sup> energy distribution - 1U Basic Power Distribution Units (PDU)



6 468 36

To provide ~ electric power for IT equipment in enclosures. 230 V - 50/60 Hz power supply. 1U aluminium profile. End cap with metallic brackets and cable holder shape. Quick fixing (no screws) on 19" fixing centers. Can also be installed vertically by reverting the brackets (no screws)

2P+E outlets:

- C13 and C19 standard outlets are equipped with cord locking system to avoid any accidental disconnection. Universal solution compatible with all the cords (C14 plugs for C13 and C20 plugs for C19).
- French, German and British standard outlets are equipped with safety shutters
- French and German standard outlets are inclined at 55°

Black modules (outlets and functions)

| Pack | Cat.Nos  | 19" Basic PDU with protection devices   |
|------|----------|---|
|      |          | MCB and RCBO support with projecting edges to avoid accidental breakdown<br>3 m power supply cord with 16 A 2P+E French/German plug   |
|      |          | <b>German standard</b>  |
| 1    | 6 468 31 | 6 outlets and a 16 A single pole Micro Circuit Breaker  |
| 1    | 6 468 32 | 9 outlets and a 16 A single pole Micro Circuit Breaker, 2 U height  |
|      |          | <b>French standard</b>  |
| 1    | 6 468 30 | 6 outlets and a 16 A single pole Micro Circuit Breaker  |
| 1    | 6 468 33 | 6 outlets and a 16 A 30 mA Residual-current Circuit   |
|      |          | <b>19" Basic PDU with surge protection</b>  |
|      |          | Protect against mains overvoltages while keeping outlets energised<br>With light indicators:<br>- one LED (white) gives information whether the PDU is supplied with power or not<br>- one LED (green) indicates when surge protection module is efficient or must be replaced<br>Equipped with hotswappable surge protection module Cat.No 6 468 97: even when the module is being replaced, the PDU and its outlets are still powered on<br>3 m power supply cord with 16 A 2P+E French/German plug |
| 1    | 6 468 36 | 6 outlets - German standard - with switch   |
| 1    | 6 468 35 | 6 outlets - French standard - with switch   |
| 1    | 6 469 03 | 7 outlets - German standard   |

## Legrand cabling system LCS<sup>3</sup> energy distribution - PDUs to be equipped, accessories and DIN rails



6 468 90

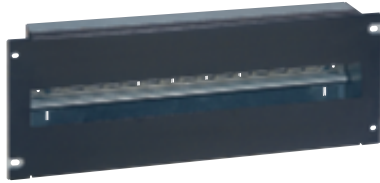

0 465 46 + 0 465 47

| Pack   | Cat.Nos  | PDU to be equipped   |
|--|----------|--|
| 1  | 6 468 99 | Quick fixing (no screws) on 19" uprights<br>Aluminium profile  |
| 1  | 6 468 98 | 19" PDU<br>Capacity: 16 Mosaic modules   |
|  |          | 10" PDU<br>Capacity: 8 Mosaic modules  |
| <b>PDU accessories</b>   |          |  |
| <b>Locking caps</b>  |          |  |
| To block the use of an outlet. A key is necessary to remove the cap and free the access<br>Light grey RAL 7035   |          |  |
| 6  | 6 468 90 | Set of 6 locking caps for French, Italian and German standard outlet + 1 key   |
| 6  | 6 468 92 | Set of 6 locking caps for British standard outlet + 1 key  |
| 6  | 6 468 96 | Set of 6 locking caps for Swiss standard T13 or T23 outlet + 1 key   |
| 6  | 6 468 94 | Set of 6 locking caps for C13 outlet + 1 key   |
| 6  | 6 468 95 | Set of 6 locking caps for C19 outlet + 1 key   |
| <b>Surge protection module</b>   |          |  |
| To replace used module on PDU<br>With light indicators:<br>- 1 LED (white) to indicate voltage presence<br>- 1 LED (green/red) to indicate the status of the surge protection module<br>Hotswappable surge protection module: even when the module is being replaced, the PDU and its outlets are still powered on |          |  |
| 1  | 6 468 97 |  |
| <b>Multi-application DIN rail</b>  |          |  |
| For mounting modular devices (circuit breakers, Legrand multimedia network components, etc)<br>Capacity: 24 modules<br>Height 4 U<br>Screw fixing on 19" uprights<br>DIN profile rail with front panel<br>Supplied with blanking plates  |          |  |
| 1  | 0 465 46 | 24 modules<br>Black RAL 9005   |
| 1  | 0 465 47 | Rear cover<br>To be used for high current applications (greater than 50 V)<br>To be associated with DIN profile rail Cat.No 0 465 46<br>Ensures IP XXB<br>Supplied with terminal block (8 + 1 connections) |

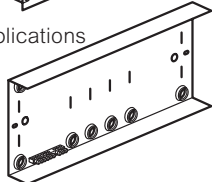
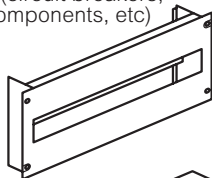
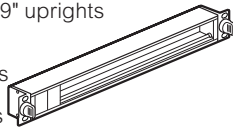

## METERED AND SWITCHED PDUS

# Intelligent PDUs

for even more reliable data centers!

Meeting your needs for energy while incorporating intelligent functions, including real-time power metering and environmental monitoring? It's possible with Legrand's connected PDUs (iPDUs)!

### ACCURATE +/-1% POWER INPUT MEASUREMENT

Accurate energy consumption measurements with multiple configurations possible.

### BEST-IN-CLASS CONTROLLER FEATURES

- Dual 10/100 Ethernet ports
- USB Type-A and Type-B ports
- CLI management port
- Color Coded Alert Screen

### REMOTE OUTLET MANAGEMENT GROUPING

- For checking that devices are only plugged in on available circuits.
- Switched models allow users to deactivate unavailable sockets remotely for load shedding or protection.



### COMPATIBLE WITH RARITAN SMARTSENSORS

All Raritan SmartSensors work out of the box with Legrand intelligent PDUs, are easily integrated in the cabinet, can be connected in a daisy chain and can be replaced without having to rewire the cabinet.

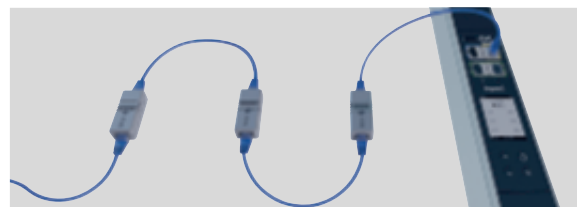

All Legrand intelligent PDUs can be monitored and managed remotely through a secured Web User Interface !



Contact your local sales rep for more information!

## Applications distances according to category of cabling

| Application | Frequency <sup>(1)</sup> | LCS <sup>3</sup> Cat.5e | LCS <sup>3</sup> Cat.6  | LCS <sup>3</sup> Cat.6A | LCS <sup>3</sup> Cat.8 |
|-------------|--------------------------|-------------------------|-------------------------|-------------------------|------------------------|
|             |                          | 100MHz                  | 250MHz                  | 500MHz                  | 2000MHz                |
| 1000Base-T  |                          | 100m                    | 100m                    | 100m                    | 100m                   |
| 2.5Gbase-T  |                          | Possible <sup>(2)</sup> | Possible <sup>(2)</sup> | 100m                    | 100m                   |
| 5Gbase-T    |                          | Possible <sup>(2)</sup> | Possible <sup>(2)</sup> | 100m                    | 100m                   |
| 10Gbase-T   |                          | N/A <sup>(4)</sup>      | Possible <sup>(3)</sup> | 100m                    | 100m                   |
| 25Gbase-T   |                          | N/A <sup>(4)</sup>      | N/A <sup>(4)</sup>      | Possible <sup>(5)</sup> | 30m                    |
| 40Gbase-T   |                          | N/A <sup>(4)</sup>      | N/A <sup>(4)</sup>      | Possible <sup>(5)</sup> | 30m                    |

- 1: Maximum frequency defined in the standards
- 2: Follow ISO/IEC TR 11801-9904 or TIA TSB 5021 to evaluate possibility on installed links. Distance will depend on many factors.
- 3: Follow ISO/IEC TR 24750 or TIA TSB 155-A to evaluate possibility on installed links. Distance will depend on many factors.
- 4: Not Available.
- 5: Follow ISO/IEC TR 11801-9905 to evaluate possibility on installed links. Distance will depend on many factors.

## Compliance of LCS<sup>3</sup> systems with standards and certifications

LCS<sup>3</sup> systems and components (de-embedded) conform to the following standards:

- ANSI/TIA 568
- EN 50173-1

- ISO/IEC 11801 Edition 3 (2017)

The LCS<sup>3</sup> system supports 10 G applications Base-T up to 100 m in a transmission channel

Conforming to standards: ISO/IEC 11 801, EN 50173, ANSI/TIA 568  
LCS<sup>3</sup> systems are certified by the 3P independent laboratory, a reference body on the subject



## Names for LAN cables (according to ISO 11801-2)

They correspond to: "type of cable shielding"/"type of twisted pair shielding" followed by TP (for twisted pairs)

| Type of cable |          | Cable shielding                                | Shielding of twisted pairs                                     |
|---------------|----------|--|--|
| old name      | new name |  |  |
| SSTP          | S/FTP    | S: screen made of copper braid                 | F: screen formed from an alu/ polyester ribbon<br>U: no screen |
| SFTP          | SF/UTP   | SF: combination of ribbon + braid              | F: screen formed from an alu/ polyester ribbon<br>U: no screen |
| STP           | U/FTP    | U: no screen                                   | F: screen formed from an alu/ polyester ribbon<br>U: no screen |
| FTP           | F/FTP    | F: screen formed from an alu/ polyester ribbon | F: screen formed from an alu/ polyester ribbon<br>U: no screen |
| FTP           | F/UTP    | F: screen formed from an alu/ polyester ribbon | U: no screen   |
| UTP           | U/UTP    | U: no screen                                   | U: no screen   |

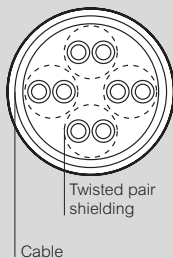

## Dimensions (in mm)

Cat.No 0 337 96

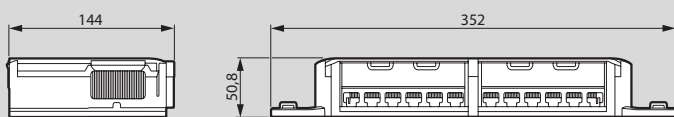

Cat.No 0 337 97

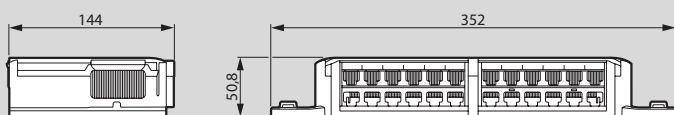

The Innoval training centre offers LCS<sup>3</sup> certification, see [our website](#)

**25-year guarantee:** Legrand is committed to delivering a durable LCS<sup>3</sup> system, see [our website](#)

## Performance when installed with a zone distribution box (consolidation point)

Maximum recommended lengths of links to ensure high performance of systems when using RJ 45 sockets with copper feedthroughs and/ or RJ 45 sockets

**Performances for use of zone distribution boxes in 20°C environment**

**The distances below correspond to the most typical cases using preterminated solutions**

All other standard-compliant configurations are possible, including configurations with use of cables to be connected on site  
Refer to technical sheets for more information

a) Use of the area cabling cord in a channel with a Consolidation Point:

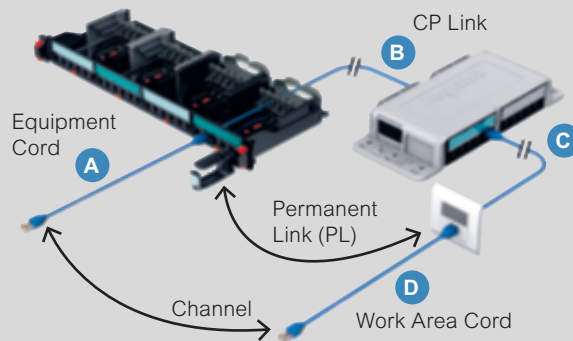

| CP Cord C | CP Link B | Equipment Cord A | Work Area Cord D | Total Channel |
|-----------|-----------|------------------|------------------|---------------|
| 8 m       | 74 m      | 5 m              | 5 m              | 92 m          |
| 15 m      | 63 m      | 5 m              | 5 m              | 88 m          |
| 20 m      | 56 m      | 5 m              | 5 m              | 86 m          |

b) Use of the area cabling cord in a channel with a MUTOA (Multi-User Telecommunications Outlet Assembly):

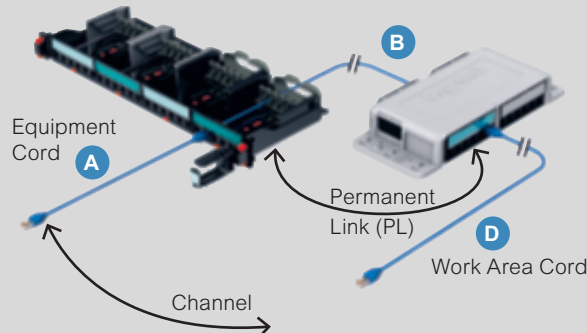

| Work Area Cord D | Permanent Link B | Equipment Cord A | Total Channel |
|------------------|------------------|------------------|---------------|
| 8 m              | 82 m             | 5 m              | 90 m          |
| 15 m             | 72 m             | 5 m              | 87 m          |
| 20 m             | 64 m             | 5 m              | 84 m          |



## Legrand cabling system LCS<sup>3</sup> - copper (continued)

### PoE certification

Using PoE technology, devices such as Wi-Fi access points, cameras, etc. can be supplied with power by the Ethernet data cable. The cable combines data and power to supply all the PoE peripherals. The LCS<sup>3</sup> connectors are PoE++ Third Party certified.

Legrand solutions are complying as per below:

- Cables: 802.3 bt PoE++ applications compatible according to installation standards ISO/IEC 14763-2 and EN 50174-2:2018
- Connectors: Compatible remote powering "PoE" up to 100 W (IEEE 802.3af, IEEE 802.3at, IEEE 802.3bt). Third party certified IEC 60512-99-002 for disconnection under PoE Type 4
- Patch cords: Compatible remote powering "PoE" up to 100 W (IEEE 802.3af, IEEE 802.3at, IEEE 802.3bt)" when installed according to standards ISO/IEC 14763-2 and/or EN 50174-2:2018



### Table of PoE types according to cabling requirements and power availability

| Name (Common name)                     | Type 1 (PoE)   | Type 2 (PoE+)  | Type 3 (PoE++) | Type 4 (PoE++) |
|--|----------------|----------------|----------------|----------------|
| IEEE Standard                          | 802.3af (2003) | 802.3at (2009) | 802.3bt (2018) | 802.3bt (2018) |
| Minimum Category Required              | Category 3     | Category 5e    | Category 5e    | Category 5e    |
| Number of Pairs for Power              | 2              | 2              | 2 or 4         | 4              |
| Maximum Current per Pair               | 350 mA         | 600 mA         | 600 mA         | 960 mA         |
| Guaranteed maximum Power at PSE Output | 15.4 W         | 30.0 W         | 60.0 W         | 90.0 W         |
| Guaranteed maximum Power at PE Input   | 13 W           | 25.5 W         | 51.0 W         | 71.3 W         |

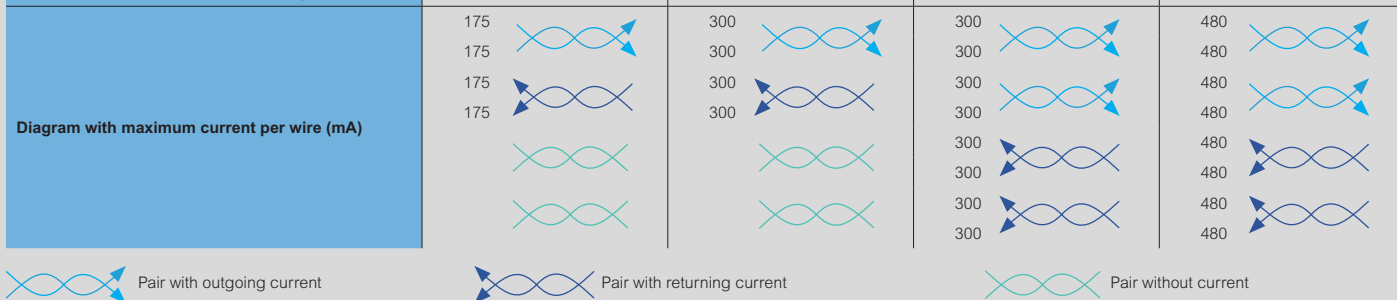

There are subdivisions of PoE called Classes. Below is a table of these Classes with correspondence to the PoE Types and the power available. It's important to note that the difference of power between the PD and the PSE does not represent an average efficiency, but only a worst case with maximum distance and highest resistance cabling.

| Class                                | 1      | 2   | 3    | 4      | 5                     | 6    | 7                     | 8    |
|--------------------------------------|--------|-----|------|--------|-----------------------|------|-----------------------|------|
| Type                                 | Type 1 |     |      | Type 2 | Type 3 <sup>(1)</sup> |      | Type 4 <sup>(2)</sup> |      |
| PSE maximum output average power (W) | 4      | 7   | 15.4 | 30     | 45                    | 60   | 75                    | 90   |
| PD Input Average Power (W)           | 3.8    | 6.5 | 13.0 | 25.5   | 40.0                  | 51.0 | 62.0                  | 71.3 |
| PD Peak operating Power (P)          | 5.0    | 8.4 | 14.4 | 28.3   | 42.0                  | 53.5 | 65.1                  | 74.9 |

1: Type 3 can also support Classes 1 to 4

2: Only single signature PD shown

### High-performance maintenance



Being committed to delivering a durable LCS<sup>3</sup> system, Legrand gives a 25-year guarantee on its performance and applications, PoE included



# Legrand cabling system LCS<sup>3</sup> - copper (continued)

## PoE architecture

Building systems are moving to a single IP Network

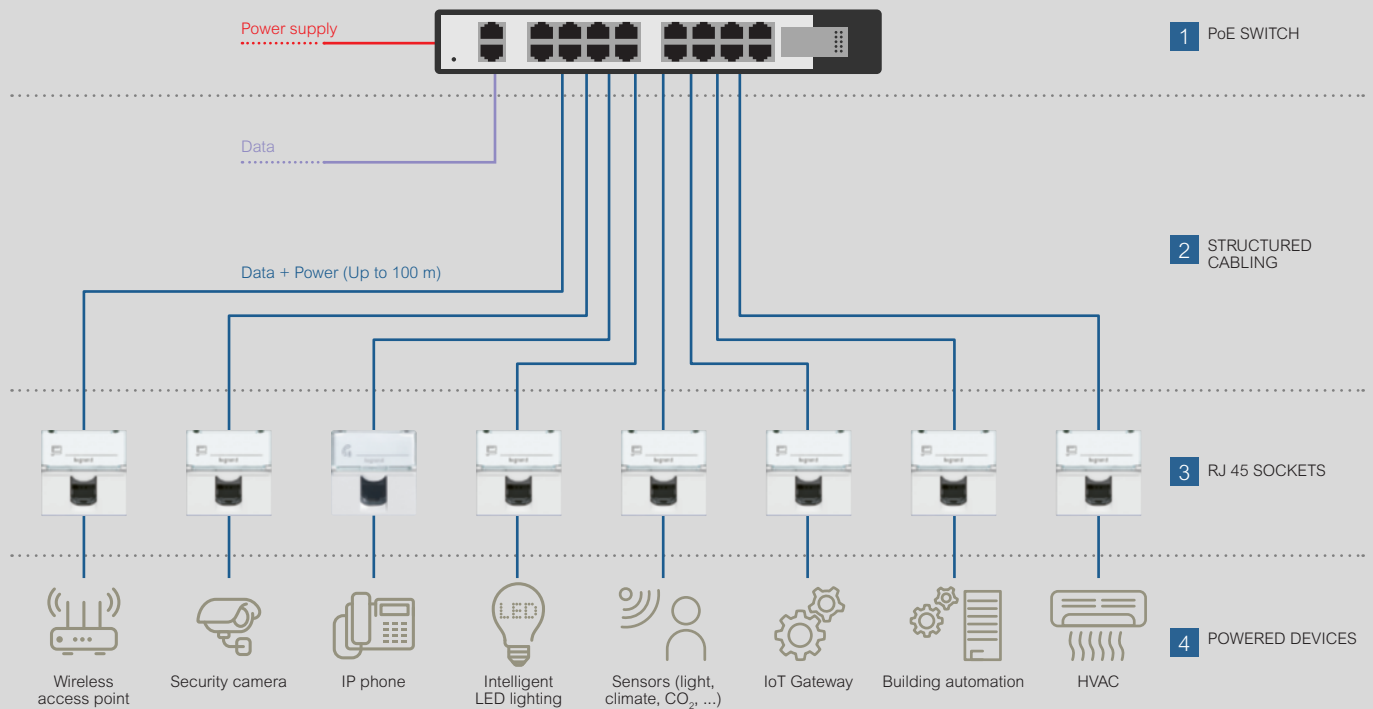

### PoE switch

A Power over Ethernet switch is a device which supplies power and data on Ethernet cabling. It draws power from its own conventional power source and provides power to the rest of the PoE system.



### Structured cabling

The twisted pairs cable is the power and data transmission medium of a PoE system. It is used to provide the link between two devices enabling bidirectional communication and uni-directional supply of power.



### RJ 45 sockets

Universal RJ 45 socket to connect devices.



### Powered devices

A powered device is a device which receives power from the power sourcing equipment. It does not require its own conventional power source.

**Shielded Category 6A cabling is recommended for optimum future-proofing and is the best choice for the Internet of Things and is recommended by current design standards for BIoT.**

## Legrand cabling system LCS<sup>3</sup> - copper (continued)

### Construction Products Regulation (CPR)

The CPR is a European law published in 2011, with a classification ratified in 2016, to impose minimum fire performance to products installed permanently in buildings. It covers, among other items, the communications cables fixed in the building, but not the removable items such as patch cords and user cords. Vendors are required to comply since July 1st, 2017 and the fire rating must be identified on the cable packaging along with the CE mark. The associated declaration of performance (DoP) must be made available to customers.

The EU regulation enforcing the standard by law is applicable to all European Economic Area (E.E.A.) member states: Austria, Belgium, Bulgaria, Croatia, Cyprus, the Czech Republic, Denmark, Estonia, Finland, France, Germany, Greece, Hungary, Ireland, Italy, Latvia, Lithuania, Luxembourg, Malta, the Netherlands, Poland, Portugal, Romania, Slovakia, Slovenia, Spain, Sweden, the United Kingdom.

It also applies in the countries voluntarily participating to be part of the single market: Iceland, Liechtenstein, Norway and Switzerland. In addition, four other countries are E.U. candidates and in the process of incorporating EU legislation into national law: Montenegro, Macedonia, Serbia and Albania. Finally, Turkey is an associate member, voluntarily following EU regulations.

The classification consists of 7 Euroclasses which define the fire reaction performance. Below is a table summarizing the classification:

| Testing and level of control |   | A <sub>CA</sub> | B1 <sub>CA</sub> | B2 <sub>CA</sub> | C <sub>CA</sub> | D <sub>CA</sub> | E <sub>CA</sub> | F <sub>CA</sub> |
|------------------------------|---|-----------------|------------------|------------------|-----------------|-----------------|-----------------|-----------------|
| Euro classification          | Gross heat of combustion                          | yes             | -                | -                | -               | -               | -               | -               |
|                              | Flame propagation                                 | -               | yes              | yes              | yes             | yes             | yes             | no              |
|                              | Heat release                                      | -               | yes              | yes              | yes             | yes             | no              | no              |
| Additional criteria          | Smoke production, flaming droplets, smoke acidity | -               | yes              | yes              | yes             | yes             | no              | no              |
| Control of compliance        | Type Testing by independent lab                   | yes             | yes              | yes              | yes             | yes             | yes             | no              |
|                              | Production sampling by certification body         | yes             | yes              | yes              | yes             | no              | no              | no              |

### Explanation of the Euroclasses

| Euroclass        | Reaction to fire                                    | Comments   |
|------------------|---|--|
| A <sub>CA</sub>  | Non combustible                                     | It is near-impossible to produce non-combustible communication cable.  |
| B1 <sub>CA</sub> | Various level of flame propagation and heat release | D <sub>CA</sub> is the lowest cable type with all aspect tested and certified by an independent laboratory. Higher classes offer improved resistance to flame propagation and heat release but their additional criteria could be identical. |
| B2 <sub>CA</sub> |   |  |
| C <sub>CA</sub>  |   |  |
| D <sub>CA</sub>  |   |  |
| E <sub>CA</sub>  | Minimum flame propagation testing                   | Heat release is not tested. Additional requirements are not tested, so the spread of fire is controlled, but the evacuation of people is limited due to toxic fumes. This is the first level of cable to require independent testing.        |
| F <sub>CA</sub>  | No testing  | Offers absolutely no guarantees. Should be avoided.  |

### Definitions of the additional criteria

| Smoke production | Performance  | Particles / Droplets | Performance                      |
|------------------|--|----------------------|----------------------------------|
| s1               | Very low smoke production                          | d0                   | No droplets / flaming particles  |
| s1a              | Very low smoke production and high transmittance   | d1                   | Low droplets / flaming particles |
| s1b              | Very low smoke production and medium transmittance | d2                   | No performance guaranteed        |
| s2               | Average smoke production                           |                      |                                  |
| s3               | No performance guaranteed                          |                      |                                  |
|                  |  | Smoke acidity        | Performance                      |
|                  |  | a1                   | Very low smoke acidity           |
|                  |  | a2                   | Low smoke acidity                |
|                  |  | a3                   | No performance guaranteed        |

These additional criteria are added after the letter of the Euroclass in order s, d, a. and they allow for more than 200 combinations. For obvious reasons, most will not exist, and only the most useful ones will be used.

It is important to understand that the lowest rating in each type means that the product actually does not meet the requirements.

## Legrand cabling system LCS<sup>3</sup> - copper (continued)

### Euroclass table

| Cat.Nos  | Description               | Euroclass (A <sub>ca</sub> ; B1 <sub>ca</sub> ; B2 <sub>ca</sub> ; C <sub>ca</sub> ; D <sub>ca</sub> ; E <sub>ca</sub> ; F <sub>ca</sub> ) | Additional criteria<br>(smoke production, flaming droplets, acidity) |    |    |
|----------|---------------------------|--|--|----|----|
|          |                           |  |  |    |    |
| 0 327 50 | C5e U/UTP 4P LSZH CABLE   | D <sub>ca</sub>  | s2   | d2 | a1 |
| 0 327 51 | C5e U/UTP 4P PVC CABLE    | E <sub>ca</sub>  | -  | -  | -  |
| 0 327 52 | C5e F/UTP 4P LSZH CABLE   | D <sub>ca</sub>  | s2   | d2 | a1 |
| 0 327 53 | C5e F/UTP 4P PVC CABLE    | E <sub>ca</sub>  | -  | -  | -  |
| 0 327 54 | C6 U/UTP 4P LSZH CABLE    | D <sub>ca</sub>  | s2   | d2 | a1 |
| 0 327 55 | C6 U/UTP 4P PVC CABLE     | E <sub>ca</sub>  | -  | -  | -  |
| 0 327 56 | C6 F/UTP 4P LSZH CABLE    | D <sub>ca</sub>  | s2   | d2 | a1 |
| 0 327 57 | C6 SF/UTP 4P LSZH CABLE   | D <sub>ca</sub>  | s1   | d1 | a1 |
| 0 327 58 | C6 F/UTP 4P PVC CABLE     | E <sub>ca</sub>  | -  | -  | -  |
| 0 327 59 | C6 SF/UTP 4P PVC CABLE    | E <sub>ca</sub>  | -  | -  | -  |
| 0 327 76 | C6 F/UTP 2x4P LSZH CABLE  | D <sub>ca</sub>  | s2   | d2 | a1 |
| 0 327 77 | C7 S/FTP 4P LSZH CABLE    | D <sub>ca</sub>  | s2   | d2 | a1 |
| 0 327 78 | C6A F/UTP 4P LSZH CABLE   | D <sub>ca</sub>  | s2   | d2 | a1 |
| 0 327 79 | C7 S/FTP 2X4P LSZH CABLE  | D <sub>ca</sub>  | s2   | d2 | a1 |
| 0 327 87 | C6A U/UTP 4P LSZH CABLE   | D <sub>ca</sub>  | s2   | d2 | a1 |
| 0 327 98 | C6A F/FTP 2X4P LSZH CABLE | D <sub>ca</sub>  | s2   | d2 | a1 |
| 0 327 99 | CÂBLE C6A F/FTP 4P LSZH   | D <sub>ca</sub>  | s2   | d2 | a1 |
| 0 328 28 | C6A U/UTP 4P LSZH CABLE   | C <sub>ca</sub>  | s1a  | d1 | a1 |
| 0 328 38 | C6A U/UTP 4P LSZH CABLE   | B2 <sub>ca</sub>   | s1a  | d1 | a1 |
| 0 328 49 | C7 S/FTP 4P LSZH CABLE    | C <sub>ca</sub>  | s1a  | d1 | a1 |
| 0 328 50 | C5e F/UTP 4P LSZH CABLE   | D <sub>ca</sub>  | s2   | d2 | a1 |
| 0 328 53 | C5e U/UTP 4P LSZH CABLE   | D <sub>ca</sub>  | s2   | d2 | a1 |
| 0 328 56 | C6 F/UTP 4P LSZH CABLE    | D <sub>ca</sub>  | s2   | d2 | a1 |
| 0 328 57 | C6 F/UTP 4P PVC CABLE     | E <sub>ca</sub>  | -  | -  | -  |
| 0 328 61 | C6 U/UTP 4P LSZH CABLE    | D <sub>ca</sub>  | s2   | d2 | a1 |
| 0 328 78 | C6A F/UTP 2X4P LSZH CABLE | D <sub>ca</sub>  | s2   | d2 | a2 |
| 0 328 79 | C6 U/UTP 4P LSZH CABLE    | B2 <sub>ca</sub>   | s1a  | d1 | a1 |
| 0 328 82 | C7 S/FTP 4P LSZH CABLE    | B2 <sub>ca</sub>   | s1a  | d1 | a1 |
| 0 328 83 | C6A F/FTP 4P LSZH CABLE   | C <sub>ca</sub>  | s1a  | d1 | a1 |
| 0 328 84 | C6A U/FTP 4P LSZH CABLE   | C <sub>ca</sub>  | s1a  | d1 | a1 |
| 0 328 86 | C6 U/UTP 4P LSZH CABLE    | C <sub>ca</sub>  | s1a  | d1 | a1 |
| 0 328 88 | C6 U/UTP 100P LSZH CABLE  | E <sub>ca</sub>  | -  | -  | -  |
| 0 338 90 | C7 S/FTP 4P LSZH CABLE    | E <sub>ca</sub>  | -  | -  | -  |
| 0 328 91 | C3 U/UTP 50P LSZH CABLE   | E <sub>ca</sub>  | -  | -  | -  |
| 0 337 88 | C8 S/FTP 4P LSZH CABLE    | D <sub>ca</sub>  | s2   | d2 | a1 |

# Legrand cabling system, LCS<sup>3</sup> fiber optic

## Duplex applications, functioning on Duplex LC

| Duplex  | OM3                 | OM4                 | OM5                 | OS1a               | OS2                 |
|---------|---------------------|---------------------|---------------------|--------------------|---------------------|
| 10Gbps  | 300m <sup>(1)</sup> | 400m <sup>(1)</sup> | 400m <sup>(1)</sup> | 2km <sup>(1)</sup> | 10km <sup>(1)</sup> |
| 25Gbps  | 70m <sup>(1)</sup>  | 100m <sup>(1)</sup> | 100m <sup>(1)</sup> | 2km <sup>(1)</sup> | 10km <sup>(1)</sup> |
| 40Gbps  | 240m <sup>(2)</sup> | 350m <sup>(2)</sup> | 440m <sup>(2)</sup> | 2km <sup>(1)</sup> | 10km <sup>(1)</sup> |
| 50Gbps  | 70m <sup>(1)</sup>  | 100m <sup>(1)</sup> | 100m <sup>(1)</sup> | 2km <sup>(1)</sup> | 10km <sup>(1)</sup> |
| 100Gbps | 70m <sup>(2)</sup>  | 100m <sup>(2)</sup> | 150m <sup>(2)</sup> | 2km <sup>(1)</sup> | 10km <sup>(1)</sup> |
| 200Gbps | N/A <sup>(3)</sup>  | N/A <sup>(3)</sup>  | N/A <sup>(3)</sup>  | 2km <sup>(1)</sup> | 10km <sup>(1)</sup> |
| 400Gbps | N/A <sup>(3)</sup>  | N/A <sup>(3)</sup>  | N/A <sup>(3)</sup>  | 2km <sup>(1)</sup> | 10km <sup>(1)</sup> |

1: Standard  
2: Multi-Source Agreement  
3: Not applicable

## Parallel optics applications, functioning on 12-core MPO/MTP

| Parallel | OM3                 | OM4                 | OM5                 | OS1a                | OS2                 |
|----------|---------------------|---------------------|---------------------|---------------------|---------------------|
| 10Gbps   | N/A <sup>(2)</sup>  | N/A <sup>(2)</sup>  | N/A <sup>(2)</sup>  | N/A <sup>(2)</sup>  | N/A <sup>(2)</sup>  |
| 25Gbps   | N/A <sup>(2)</sup>  | N/A <sup>(2)</sup>  | N/A <sup>(2)</sup>  | N/A <sup>(2)</sup>  | N/A <sup>(2)</sup>  |
| 40Gbps   | 100m <sup>(1)</sup> | 150m <sup>(1)</sup> | 150m <sup>(1)</sup> | N/A <sup>(2)</sup>  | N/A <sup>(2)</sup>  |
| 50Gbps   | N/A <sup>(2)</sup>  | N/A <sup>(2)</sup>  | N/A <sup>(2)</sup>  | N/A <sup>(2)</sup>  | N/A <sup>(2)</sup>  |
| 100Gbps  | 70m <sup>(1)</sup>  | 100m <sup>(1)</sup> | 100m <sup>(1)</sup> | 500m <sup>(1)</sup> | 500m <sup>(1)</sup> |
| 200Gbps  | 70m <sup>(1)</sup>  | 100m <sup>(1)</sup> | 100m <sup>(1)</sup> | 500m <sup>(1)</sup> | 500m <sup>(1)</sup> |
| 400Gbps  | 100m <sup>(1)</sup> | 100m <sup>(1)</sup> | 150m <sup>(1)</sup> | 500m <sup>(1)</sup> | 500m <sup>(1)</sup> |

1: Standard  
2: Not applicable

16, 20 and 32 core applications not shown as they are not compatible with single 12-core MPO links  
Note that any duplex application can also function on MPO/MTP parallel optics infrastructure

## Optical performance

### MTP<sup>®</sup> connectors

|                                    | Multimode Ultra Performance*   | Singlemode Ultra Performance*  |
|------------------------------------|--|--|
| IL/Master                          | 0.1 dB typical (all fibres)<br>0.35 dB maximum (single fibre) <sup>(2,3)</sup> | 0.1 dB typical (all fibres)<br>0.35 dB maximum (single fibre) <sup>(1,4)</sup> |
| IL Max/Random*                     | 0.35 dB (single fibre)   | 0.35 dB (single fibre)   |
| Optical return loss <sup>(5)</sup> | > 20 dB  | > 60 dB (8° anglepolished)   |

1: As tested in accordance with ANSI/TIA-455-171 Method D3 / IEC 61300-3-4  
2: As tested in accordance with ANSI/TIA-455-171 Method D1 / IEC 61300-3-4  
3: As tested on 50µm fibres at a wavelength of 850 nm in accordance with IEC 61280-4-1  
4: Complies with IEC 61755-3-31/GRADE B  
5: As tested in accordance with IEC 61300-3-6 and ANSI/TIA-455-107A

\* Performance is guaranteed only with other components of the same Legrand range (Core, Ultra and Quantum). Mixing ranges or use of components of other brand may lead to a different performance of the system. The uncertainty value for field measurement with LSPM testing using a reference cord defined in ISO/IEC 14763-3 applies to field testing with proposed Legrand testing cords. Refer to the Fiber Optic Testing Guide for Legrand Solutions.

### LC, SC, LC APC, SC APC connectors

| Optical performance                 | Singlemode Ultra Performance | Multimode Ultra Performance |
|-------------------------------------|------------------------------|-----------------------------|
| IL Max/Master <sup>(*)</sup>        | 0.15 dB                      | 0.15 dB                     |
| IL Max/Random <sup>(**)(***)</sup>  | 0.25 dB                      | 0.2 dB                      |
| Typ. IL/Master <sup>(*)</sup>       | 0.12 dB                      | 0.08 dB                     |
| Typ. IL/Random <sup>(**)(***)</sup> | 0.12 dB                      | 0.10 dB                     |
| Return loss (UPC/APC)               | > 55/65 dB                   | > 25 dB                     |

\* IEC 61300-3-4  
\*\* IEC 61300-3-34  
\*\*\* Performance is guaranteed only with other components of the same Legrand range (Core, Ultra and Quantum). Mixing ranges or use of components of other brand may lead to a different performance of the system. The uncertainty value for field measurement with LSPM testing using a reference cord defined in ISO/IEC 14763-3 applies to field testing with proposed Legrand testing cords. Refer to the Fiber Optic Testing Guide for Legrand Solutions. Storage and operating temperature: -10°C to +60°C Solutions.

### Production quality control

- For MTP:  
Optical performance: 100% factory tested  
3D endface geometry (interferometry): 100% factory products controlled

- For LC, SC, LC APC, SC APC:  
Optical performance: 100% factory tested  
3D endface Geometry (interferometry): sampling quality control

## Technical characteristics

### Multimode cable

OM5 fiber is designed for wavelength multiplexing

| Type of cable                           | OM3   | OM4   | OM5   |
|---|-------|-------|-------|
| Type of fiber <sup>1</sup>              | A1a.2 | A1a.3 | A1a.4 |
| Maximum attenuation at 850 nm, dB/km    | 3     | 3     | 3     |
| Effective bandwidth at 850 nm, MHz x km | 2000  | 4700  | 4700  |
| Effective bandwidth at 953 nm, MHz x km | N/A   | N/A   | 2470  |

1: According to IEC 60793-2-10

### Single-mode cable

| Type of cable                                 | OS1a       | OS2             |
|---|------------|-----------------|
| Environment                                   | Indoor     | Indoor/ Outdoor |
| Type of fiber <sup>1</sup>                    | B1,3 or B6 |                 |
| Maximum attenuation at 1310, 1383 and 1550 nm | 1.0        | 0.4             |

1: According to IEC 60793-2-50

## Euroclass table

| Cat.Nos  | Euroclass (A <sub>ca</sub> ; B1 <sub>ca</sub> ; B2 <sub>ca</sub> ; C <sub>ca</sub> ; D <sub>ca</sub> ; E <sub>ca</sub> ; F <sub>ca</sub> ) | Additional criteria (smoke production, flaming droplets, acidity) |            |            |
|----------|--|---|------------|------------|
|          |  | s1, s1a, s1b, s2, s3  | d0, d1, d2 | a1, a2, a3 |
| 0 325 02 | D <sub>ca</sub>  | s2  | d2         | a1         |
| 0 325 03 | D <sub>ca</sub>  | s2  | d2         | a1         |
| 0 325 10 | D <sub>ca</sub>  | s2  | d2         | a1         |
| 0 325 11 | D <sub>ca</sub>  | s2  | d2         | a1         |
| 0 325 12 | D <sub>ca</sub>  | s2  | d2         | a1         |
| 0 325 13 | Not applicable   | -   | -          | -          |
| 0 325 14 | D <sub>ca</sub>  | s2  | d2         | a1         |
| 0 325 15 | Not applicable   | -   | -          | -          |
| 0 325 18 | C <sub>ca</sub>  | s1a   | d1         | a1         |
| 0 325 19 | C <sub>ca</sub>  | s1a   | d1         | a1         |
| 0 325 23 | Not applicable   | -   | -          | -          |
| 0 325 24 | Not applicable   | -   | -          | -          |
| 0 325 25 | Not applicable   | -   | -          | -          |
| 0 325 26 | C <sub>ca</sub>  | s1a   | d1         | a1         |
| 0 325 37 | D <sub>ca</sub>  | s2  | d2         | a1         |
| 0 325 38 | D <sub>ca</sub>  | s2  | d2         | a1         |
| 0 325 39 | D <sub>ca</sub>  | s2  | d2         | a1         |
| 0 325 40 | Not applicable   | -   | -          | -          |
| 0 325 41 | Not applicable   | -   | -          | -          |
| 0 325 42 | Not applicable   | -   | -          | -          |
| 0 325 43 | D <sub>ca</sub>  | s2  | d2         | a1         |
| 0 325 44 | D <sub>ca</sub>  | s2  | d2         | a1         |
| 0 325 45 | D <sub>ca</sub>  | s2  | d2         | a1         |
| 0 325 46 | Not applicable   | -   | -          | -          |
| 0 325 47 | Not applicable   | -   | -          | -          |
| 0 325 48 | Not applicable   | -   | -          | -          |
| 0 325 49 | C <sub>ca</sub>  | s1a   | d1         | a1         |
| 0 325 50 | D <sub>ca</sub>  | s2  | d2         | a1         |
| 0 325 51 | D <sub>ca</sub>  | s2  | d2         | a1         |
| 0 325 52 | D <sub>ca</sub>  | s2  | d2         | a1         |
| 0 325 53 | D <sub>ca</sub>  | s2  | d2         | a1         |
| 0 326 65 | D <sub>ca</sub>  | s2  | d2         | a1         |
| 0 326 66 | D <sub>ca</sub>  | s2  | d2         | a1         |
| 0 326 67 | D <sub>ca</sub>  | s2  | d2         | a1         |
| 0 326 68 | D <sub>ca</sub>  | s2  | d2         | a1         |

|  | Euroclass        | Classification criteria                  | Additional criteria  | AV CP system  |
|--|------------------|--|--|---|
| <b>Non-combustible (for example mineral-insulated)</b> | A <sub>ca</sub>  | EN ISO 1716<br>Gross combustion heat     | -  | *1+* including:<br>- initial type test and continuous monitoring<br>- audit and sampling test by a third-party certification body<br>Manufacturer's factory production controls |
| <b>Cables with low fire risk (different levels)</b>    | B1 <sub>ca</sub> | EN 50399<br>Heat release<br>Flame spread | Smoke production (s1a, s1b, s2, s3)<br>EN50399/<br>EN61034-2 | *3+* including:<br>- initial type test by a third-party laboratory<br>Manufacturer's factory production controls  |
|  | B2 <sub>ca</sub> |  |  |   |
|  | C <sub>ca</sub>  | EN 60332-1-2<br>Flame propagation        | Acidity (a1, a2, a3)<br>EN 50267-2-3<br>EN 50399             |   |
|  | D <sub>ca</sub>  | EN 60332-1-2<br>Flame propagation        | Flaming droplets (d0, d1, d2)<br>EN 50399                    |   |
| <b>Standard cables</b>                                 | E <sub>ca</sub>  | EN 60332-1-2<br>Flame propagation        | -  |   |
| <b>No determined performance</b>                       | F <sub>ca</sub>  | EN 60332-1-2<br>Flame propagation        | -  | *4*:<br>initial type test and manufacturer's factory production controls  |

## Cord locking system on C13 and C19 sockets

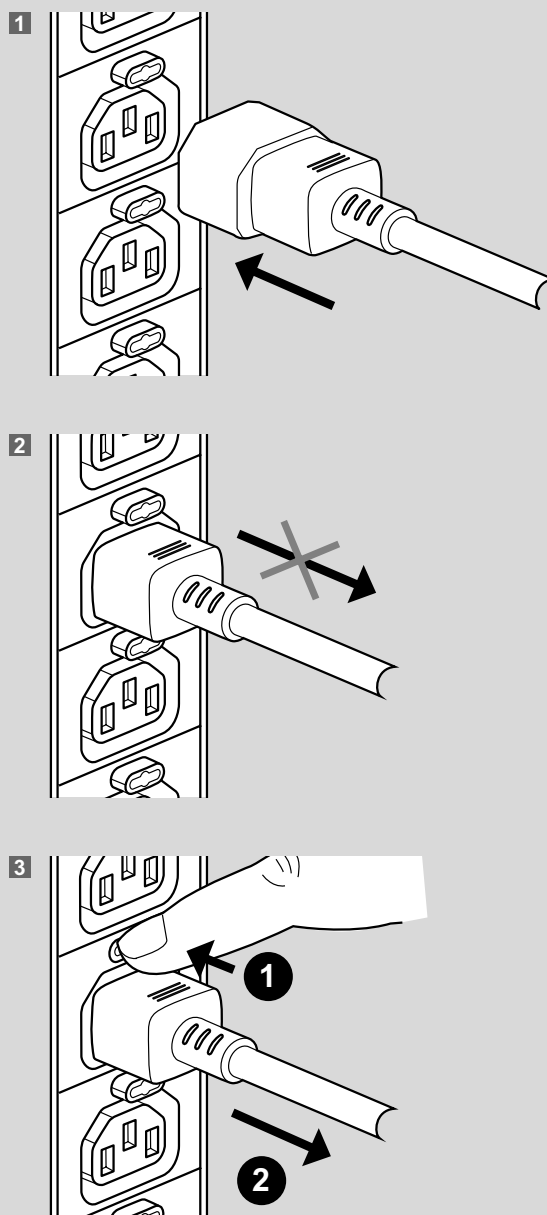

## Energy distribution

### 19" 1U PDU mounting

#### Horizontal mounting in Legrand 19" cabinets

Can be mounted in all Legrand 19" cabinets except for 19" HD racks which require the use of equipment screws Cat.No 0 464 23

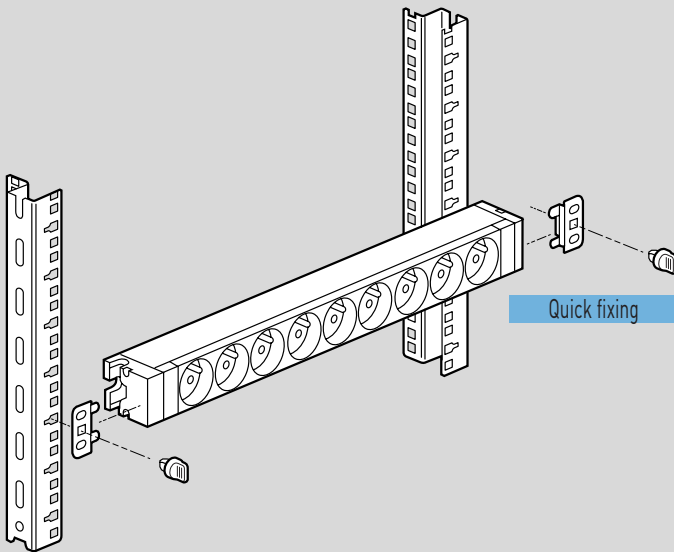

#### Vertical mounting in freestanding cabinets with support

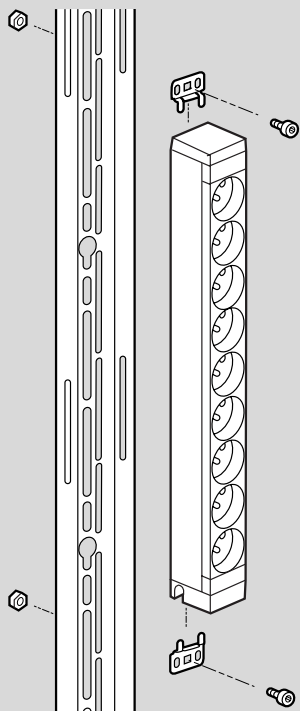

## Energy distribution

### 19" and 10" 1U PDU configurations

#### 19" 1U PDU configurations

6 468 05

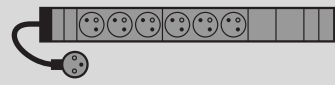

6 468 06



6 468 07



6 468 09



6 468 10



6 468 11



6 468 12



6 468 13



6 468 14



6 468 15



6 468 18/19



6 468 20



6 468 21



6 468 22



6 468 23



6 468 24

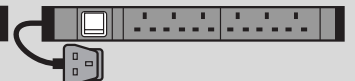

6 468 30



6 468 31



6 468 32



6 468 33

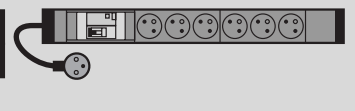

6 468 35



6 468 36



#### 10" 1U PDU configurations

6 468 00

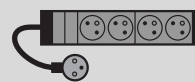

6 468 01

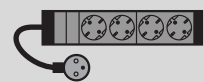





# Energy distribution

## Zero-U PDU mounting in LCS<sup>3</sup> cabinets

### ■ Solution with button brackets

Quick fixing without screws with support

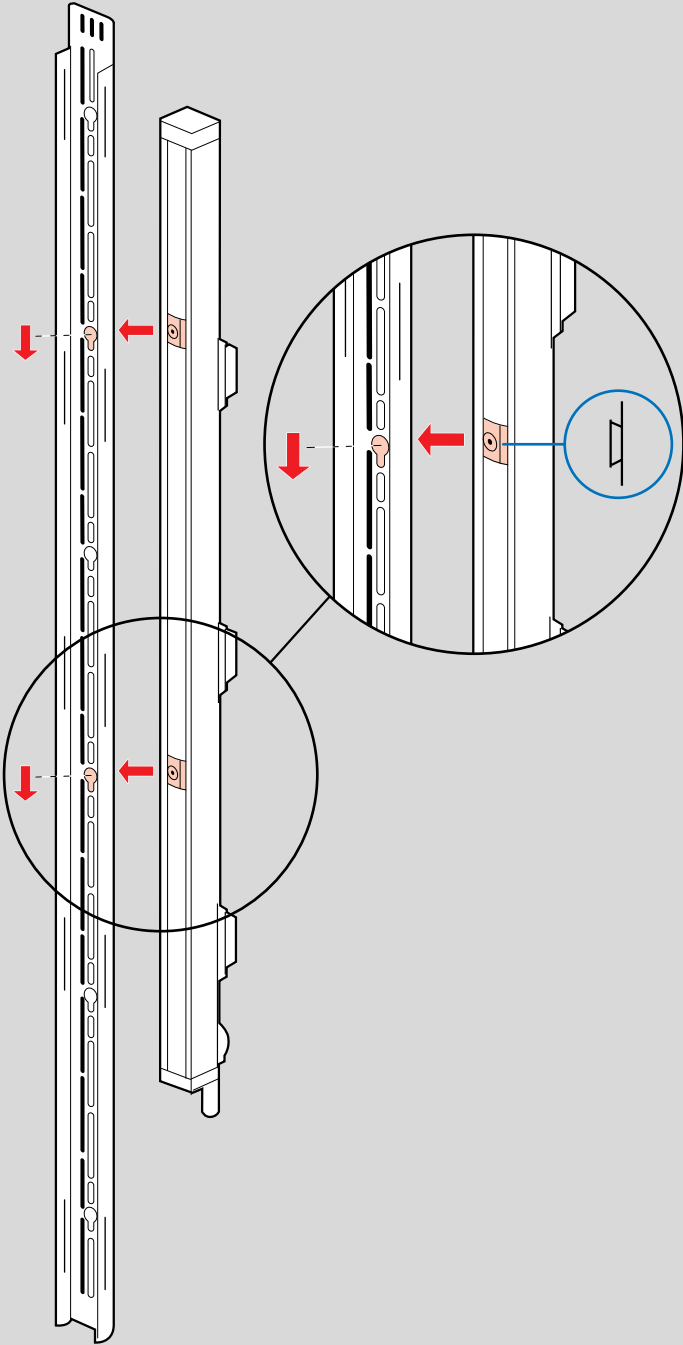

### ■ Solution with standard brackets

Screw fixing with support

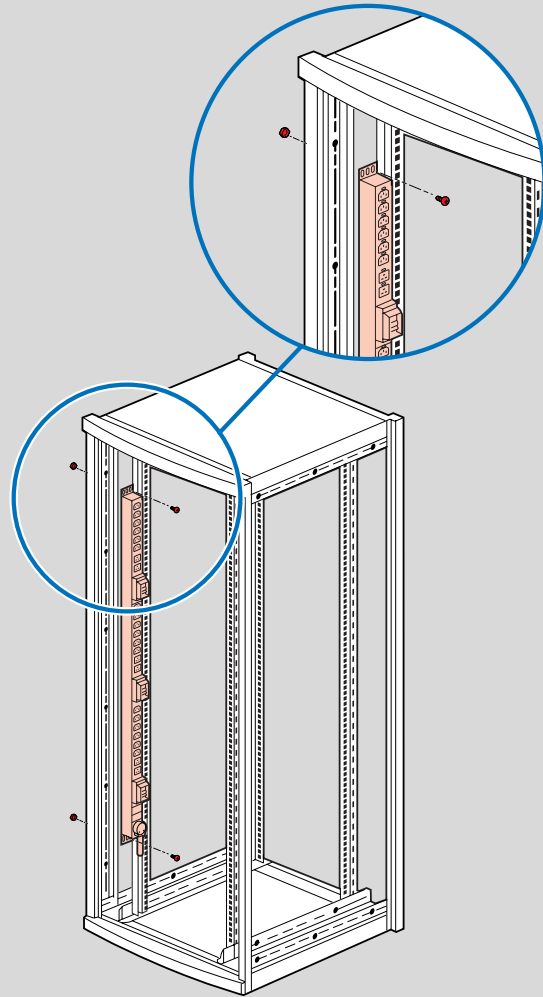

### ■ Solution with LCS<sup>3</sup> brackets

Screw fixing with support

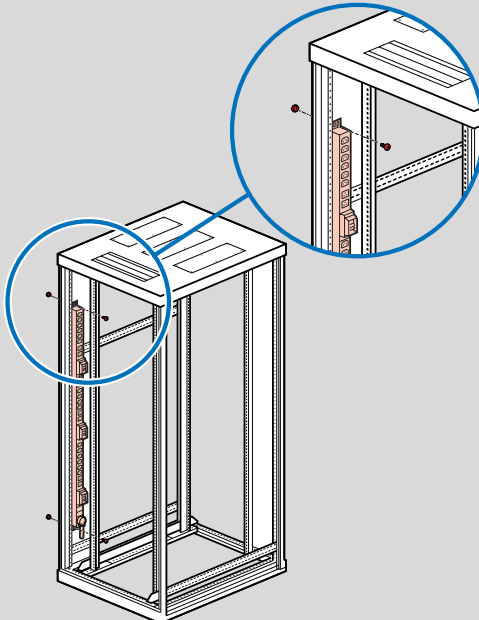







**EMB Electrical Industries S.A.E.**

**Headquarter office**

Pyramids Heights Office Park  
KM 22 Cairo - Alex. desert road  
Building 1B, 12556  
Tel.: +202 3536 0000  
Fax: +202 3536 0001  
[www.legrand.eg](http://www.legrand.eg)