

NEXPAND

DIRECT EXPANSION | ROW-BASED COOLING

TECHNICAL DATA SHEET

DX10 & DX20



THE RELIABLE AND SUSTAINABLE solution for small to medium sized data centers

Direct expansion (DX) row-based active cooling is designed according to the latest data center technology requirements and part of the Nexpan platform. The DX row-based cooling provides a smart, solid, secure, sustainable solution.



SMART
UNLIMITED POSSIBILITIES



SECURE
KEEP YOUR DATA SAFE



SOLID
THE NEXT STEP IN RELIABILITY



SUSTAINABLE
THE NEXT STEP IN ENERGY EFFICIENCY

For small and medium sized data centers we have developed row and rack-based cooling solutions based on DX (Direct Expansion) cooling technology. The DX10 and DX20 coolers are especially suited to provide precision cooling in a reliable manner and are targeted at the smaller installations, typically up to 100kW per computer room or data center. Equipped with DC inverter compressors and EC fans (both as a standard feature), this allows for a very accurate control of the desired thermal conditions but also the highest level of energy efficiency especially in partial load situations. The DX cooling solution is available as a turn-key system meaning both the indoor unit (placed adjacent to the IT cabinets) and outdoor unit are part of the delivery. The indoor unit contains the compressor, and the outdoor unit is a remote condenser. This results in more flexibility in placement of the outdoor unit and less noise emissions compared to an outdoor unit including the compressor.

The 10 and 20 kW models bring all the benefits of row-based cooling to the high density computing environment:

- Cooling equipment is close to the heat source
- Shortening the airflow path, thereby decreasing power consumption of the fan units
- Providing a fast, dynamic response of the coolers to changing heat densities.
- Sustainability is at the forefront of the Nexpan row-based cooling solutions.

The DX cooling models can be deployed between cabinets, or bayed to a single cabinet and offer a flexible architecture – the models can be used as part of a row of cabinets, or on a one cabinet to one cooler ratio or, for very high density applications, two coolers for one cabinet.

The increasing importance of intelligent automation technologies to help manage the data center environment is reflected in the DX unit's range of communications options, based on state of the art Carel hardware:

- Serial communication with RS485 comes as standard
- Ethernet communication options (SNMPv2c, BACNET, MODBUS TCP/IP) are available to facilitate Building Management System (BMS) connectivity.
- Up to 16 DX units can be connected in a LAN network with a maximum of 8 subgroups to work together in a functional manner (e.g. cooler rotation).



Indoor DX unit with integrated DC inverter compressor



Remote condenser



AIRFLOWS

Additionally, the DX units can be used as part of either an open loop (hot or cold) aisle containment system, or without aisle containment – closed loop; and can be fully integrated with both Minkels Nexpan cabinets and containment solutions.

Closed loop solution

In a closed loop solution, the indoor unit's airflows are directly guided into the adjacent 19-inch cabinets. During this process, the indoor unit extracts the hot air directly from the IT-equipment and, as cold air, guides this back to the front. No exchange of air in the room in which the setup is located takes place. The system enables you to divide the cooling capacity over several cabinets.

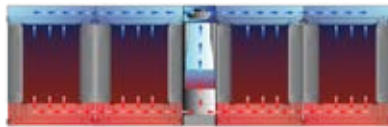

Open loop solution

In an open loop solution, the cooling air is brought directly into the room outside of the cabinets. The module extracts the hot air from the room (hot aisle) and, as cold air, guides this back to the front (cold aisle) of the cabinet. For an optimal result, it is recommended to apply the Nexpan aisle containment system when using an open loop solution.

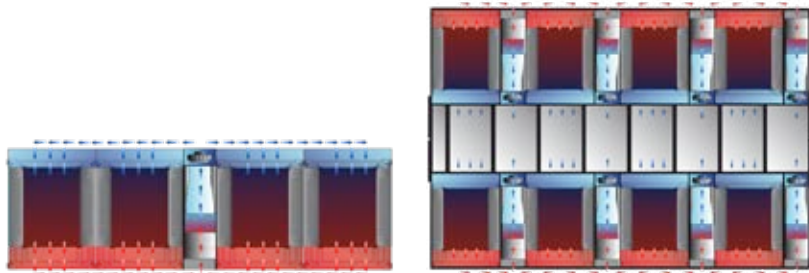

Hot and Cold Aisle Containment with row-based active cooling

The Nexpan cooling portfolio is perfectly compatible with industry standard hot-aisle and cold-aisle cooling typologies. Depending on customer specific needs either cooling strategy can be chosen and the corresponding cooling, cabinets and containment solution shall be designed and delivered as such.

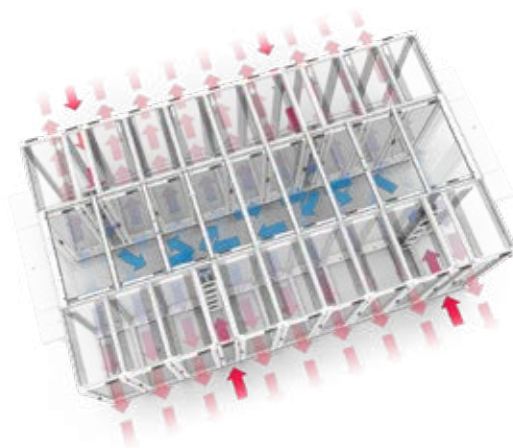

Cold aisle containment

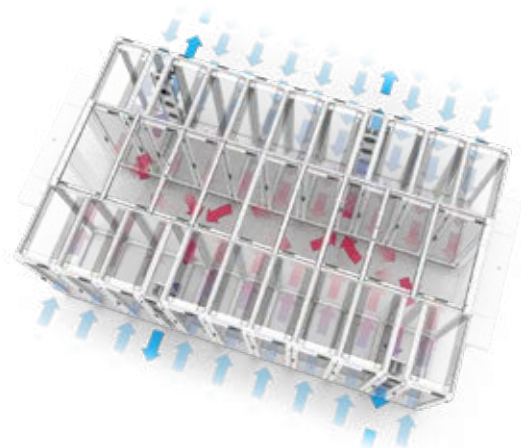

Hot aisle containment

NEXPAND

DIRECT EXPANSION | ROW-BASED COOLING Features and benefits

TOP AND BOTTOM PIPING CONNECTIONS

■ Connections for piping may enter the cooler from either the top or bottom of the unit. To facilitate this, all versions of the DX10 and DX20 accommodate top and bottom piping entry into the cooler. Also included on top and bottom are cable throughputs for connectivity, power and condensate discharge.



DISPLAY

■ The display is placed at eyesight and is seamlessly integrated in the perforated or blind doors. The latter depends on the chosen cooling configuration. It enables reading the most important values for the cooling performance, such as cold and hot aisle temperatures as well as fan speed and the degree of opening of the water valve. The standard display comes with buttons to navigate through the controller software. The display can be upgraded with a touch screen display for a more premium look and feel of the cooling solution.

ADVANCED CONTROL & MONITORING

■ To make sure you always know how the cooler is performing these are equipped with remote monitoring possibilities. Modbus RTU is standardly available as well as digital in- and outputs. This will allow you to monitor and control a vast number of business-critical parameters. Please review the list of options for more possibilities regarding remote monitoring & control.



DX10 - closed loop configuration



HOT SWAPPABLE FANS

■ The coolers are equipped with hot-swappable fans. To minimize possible downtime due to fan failure, this feature enables swift and safe replacement of the fans. The unit does not need to be turned off to replace the fan(s), so the issue of a faulty fan can be resolved in a matter of minutes.

EC FAN TECHNOLOGY

■ The fans are all equipped with EC fan technology. The benefits are an extended lifetime and a significant increase in the energy efficiency of the unit. Also, the fans are equipped with emergency speed functions. This means that even with controller downtime the fans are still running.

NEXPAND FRAME

■ The cooling technology is fully integrated in a Nexpan frame. In this way you benefit from the same look & feel throughout your white space solution. Baying to adjacent cabinets is done in the exact same way as baying IT cabinets.

SECURITY

■ As the Coolers are based on the Nexpan platform the front and rear closure is the same as with the standard IT cabinets. Apart from keeping the same look & feel it also enables the use of the same mechanical locking possibilities as with our range of IT cabinets. With this we ensure the highest level of security possible.

HYDROPHILIC COILS AND INTEGRATED FLOAT SWITCH

■ As a standard all our models feature evaporators with Hydrophilic treatment. This special coating facilitates the condensate discharge towards the drip tray which is placed below the evaporator. The purpose of the drip tray is to collect and dissipate any condensation that may occur during operation. As an extra security feature each cooler is standardly equipped with a float switch installed in the drip tray. The purpose of the float switch is to sense when a maximum level of condensate is reached. When activated, it shall give a Flooding Alarm. If this alarm occurs, it may indicate a blocked condensate discharge and/or excessive condensation. Our specialist will always offer a solution that works with 100% of sensible cooling capacity. However, in the rare cases condensate might occur it is re-assuring this is properly taken care of.



DX20 - open loop configuration



SLIDE-OUT ELECTRICAL BOX

■ The electrical box is designed to take up as little space as possible without interfering with air distribution over the whole working height of the unit. To achieve this, without affecting accessibility during the initial start-up and unscheduled maintenance operations, a sliding drawer version has been created. This design also prevents tangling of the wiring whilst sliding.

NEXPAND

DIRECT EXPANSION | ROW-BASED COOLING

Options

You can expand your DX cooler with various options. Find the possibilities below

CONDENSATE PUMP

■ When condensate discharge via gravity is not possible because of a concrete floor or other limitations, a condensate pump can be chosen. This will get rid of any condensate that may occur from the drip tray where it is collected from the heat exchanger.



TOUCH SCREEN

■ To upgrade your cooler for a more user friendly and high-tech feeling a touch screen display can be chosen. It utilizes the same cut-out in the door as the standard display so even retrofit upgrades are an easy job.

ADVANCED MONITORING

■ When monitoring through other communications protocols is a need, we can support this by upgrading with the pCOWeb card. It features communication with SNMPv2c, BACNET, Modbus over TCP/IP and it is equipped with an integrated webserver.



BASE-SET 100MM

■ When there are requirements when it comes to piping work and/or cabling underneath the cooler, a base-set which extends the height with 100mm can be deployed. The base-set is also available for our standard range of IT cabinets so the entire set-up including cooling can be perfectly aligned and have the same look & feel.

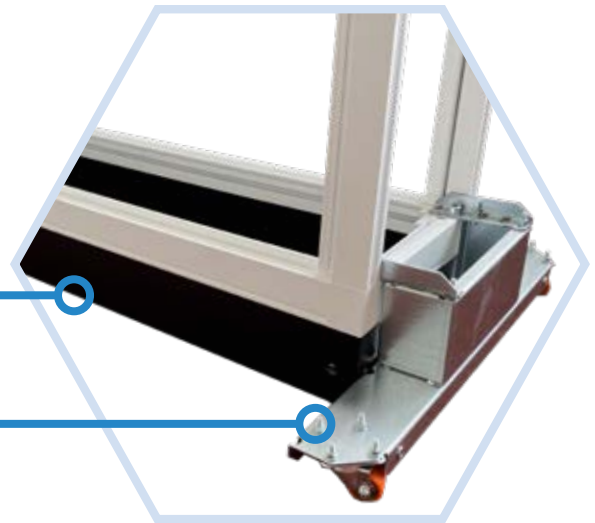

TRANSPORT TOOL

■ Safety and ease of transportation are important factors especially in the initial stages of the cooler deployment. To ensure a safe placement of the coolers which, due to their weight and form factor, have a risk of tipping over, we have developed a dedicated transport tool. The tool is easy to mount and remove and it also improves the maneuverability of the cooler in the white space area.

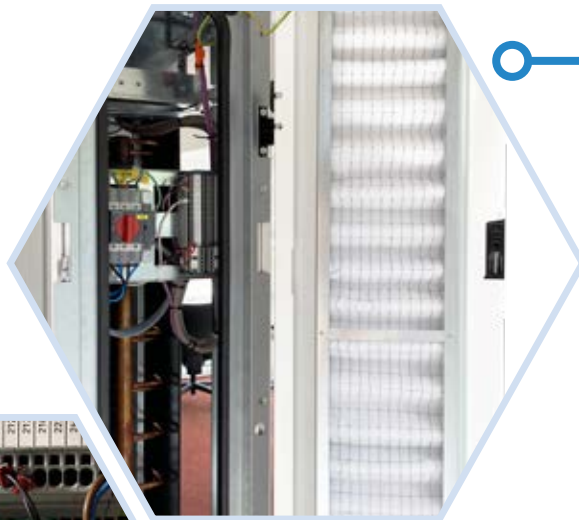

FILTER SET G4 + DIFFERENTIAL PRESSURE SENSOR

■ To collect potential dust and particles we can offer a filter set class G4. A differential pressure sensor will detect at a pre-defined threshold when it reaches the maximum pressure. This will indicate a clogged filter so it can be replaced at the next service interval or prior to that.

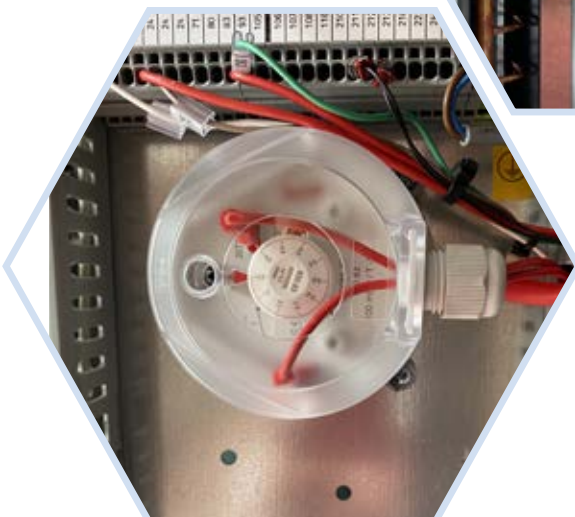

NEXPAND

DIRECT EXPANSION | ROW-BASED COOLING

Performance and specifications



GENERAL SPECIFICATIONS				
		DX10		DX20
Number of Fans	-	3		5
Fan type	-	plug EC series		plug EC series
Weight	kg	245		275
Type of fan motor	-	Brushless with integrated electronic		Brushless with integrated electronic
Oil charge	dm ³	0.5		1.4
Nominal air flow	m ³ /h	2700		4000
Connection - In (liquid)	mm	12		16
Connection - Out (gas)	mm	12		22
Lp @ Nominal rpm ; dist.= 2 m Q=2	db(A)	64		66

INDOOR UNIT					
		DX10		DX20	
Return air conditions (°C; RH)		30°C; 30%	35°C; 25%	30°C; 30%	35°C; 25%
Outside air conditions (°C; RH)		35°C; 50%	35°C; 50%	35°C; 50%	35°C; 50%
Power Supply	V/ph/Hz	230/1/50		400/3+N/50	
Cooling capacity *	kW	12.36	13.09	21.15	23.26
Net. Sensible Cooling Capacity	kW	12.09	12.82	20.45	22.57
SHR	-	1	1	1	1
Cp absorbed power	kW	3.17	3.24	7.51	7.68
Cp absorbed current	A	15.3	15.7	12	12.3
Fans absorbed power	kW	0.27	0.27	0.69	0.69
Fans absorbed current	A	1.3	1.3	3.4	3.4
Total power input	kW	3.4	3.5	8.2	8.4
Total Absorbed Current	A	16.6	17	15.4	15.7
EER	-	3.6	3.7	2.6	2.8

* A minimum heat load of 25% of the maximum Cooling Capacity must be respected to reach the optimal efficiency of the cooling system and ensure accurate setpoint control.



DX10 - closed loop configuration

DX20 - open loop configuration

REMOTE CONDENSER DATA			
		DX10	DX20
Refrigerant		R410A	R410A
Connection - In	mm	18	22
Connection - Out	mm	16	16
Air Flow	m ³ /h	4800	7200
Lp Sound Pressure level @ 10m free field	db(A)	42	44
Dimensions [L x D x H]	mm	1338x430x610	1893x430x609
Power Supply	V/ph/Hz	230/1/50	230/1/50
Fans absorbed power	W	340	510
Fans absorbed current	A	1.53	2.3
Weight	kg	38	58
Number of Fans	-	2 x 350	3 x 350
Maximum distance indoor – outdoor unit*	m	30 meters	30 meters

* For longer distances between the indoor and outdoor unit please contact your sales representative for advice.

NEXPAND

DIRECT EXPANSION | ROW-BASED COOLING

DX10 - General dimensions

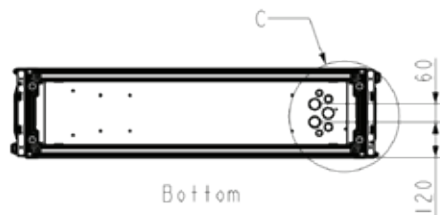
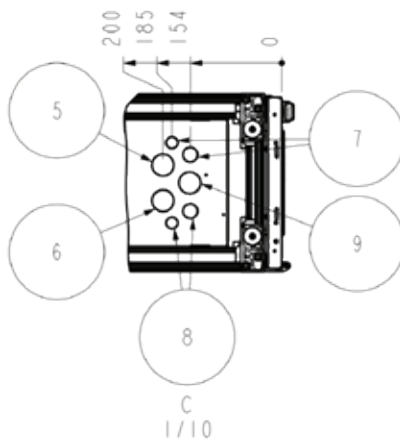
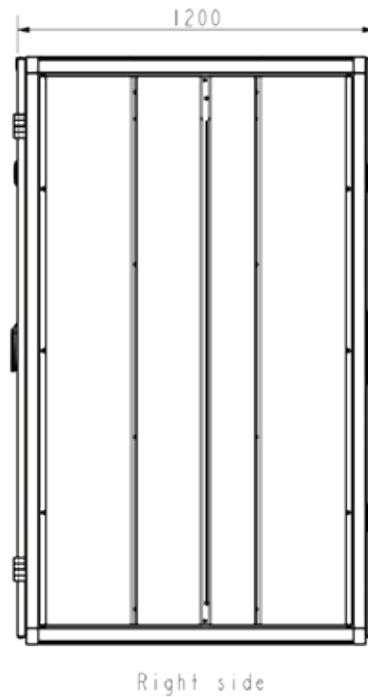
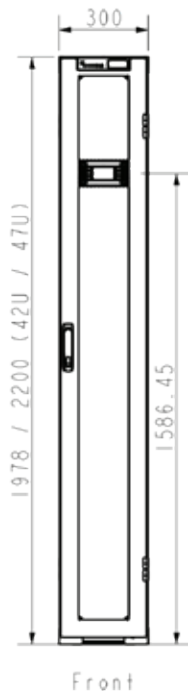
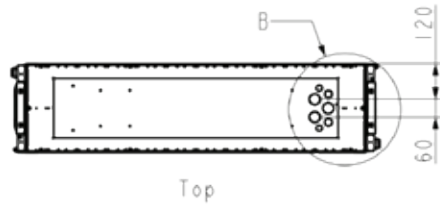
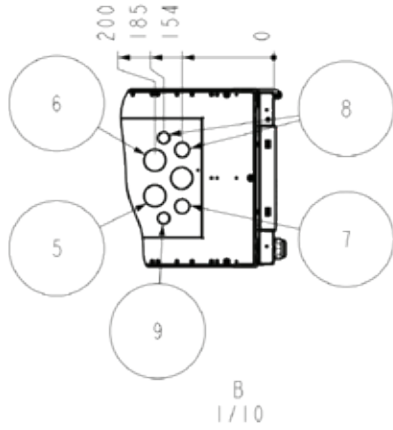

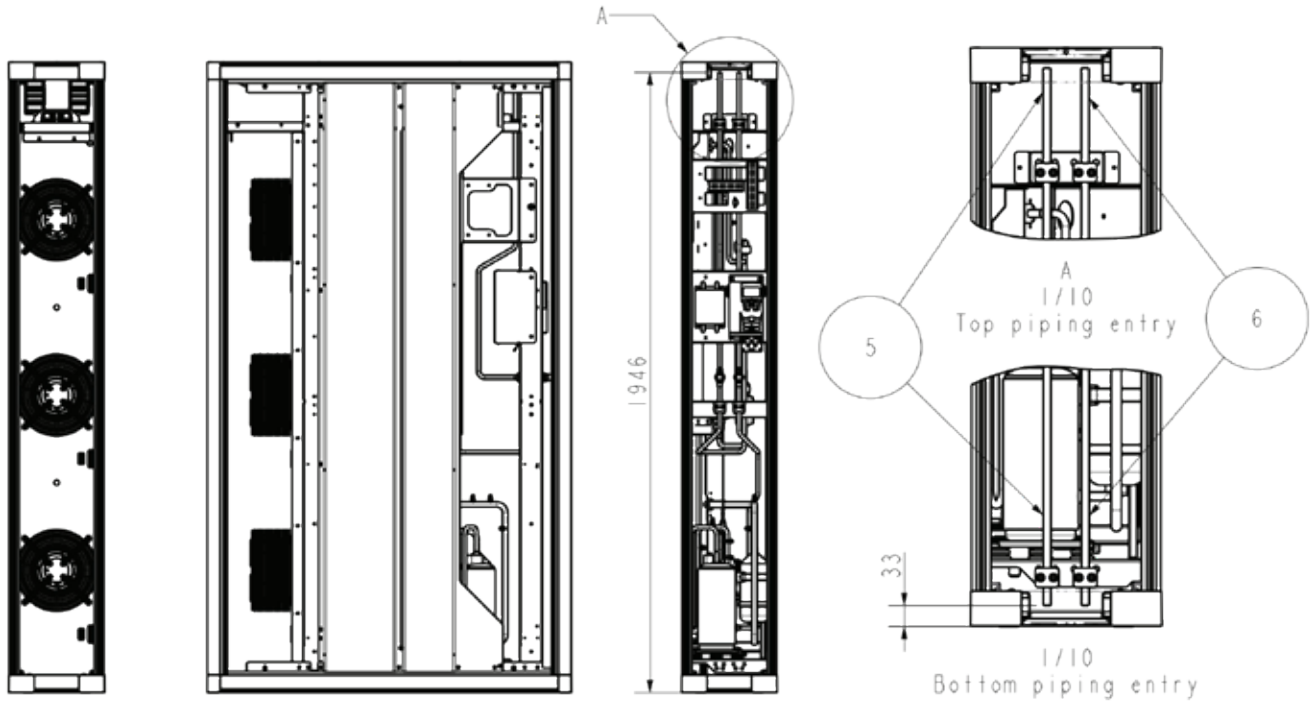

#	Description
1	Removable front door
2	Removable rear door
3	Display
4	Removable side panel
5	Liquid line inlet (rotalock 1" - Ø12)
6	Gas line outlet (rotalock 1" - Ø12)
7	Power supply
8	Data cables
9	Condensate drain

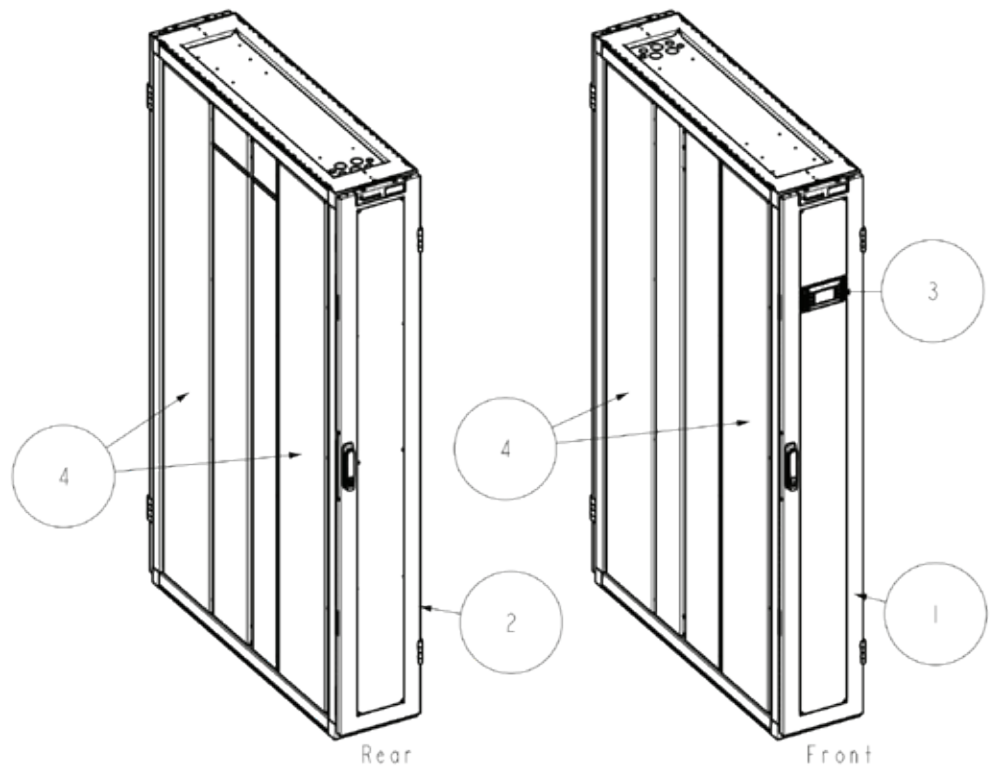

NEXPAND

DIRECT EXPANSION | ROW-BASED COOLING

DX10 - Transport tool

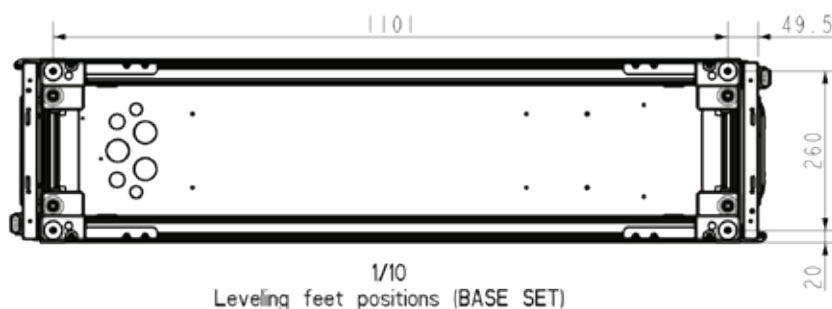
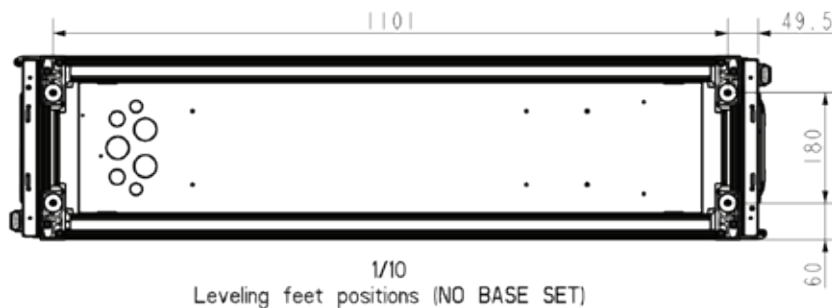
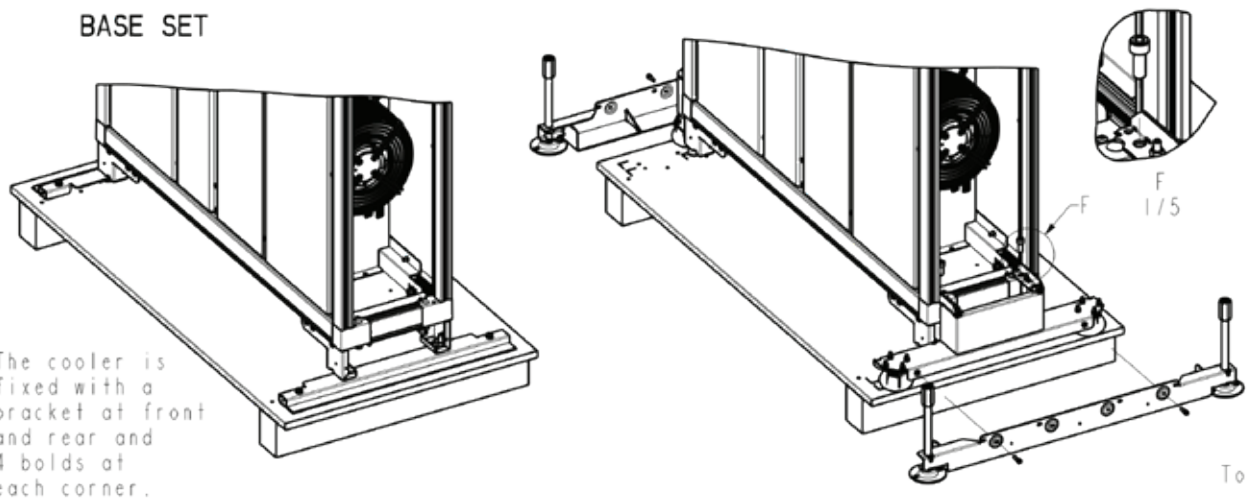
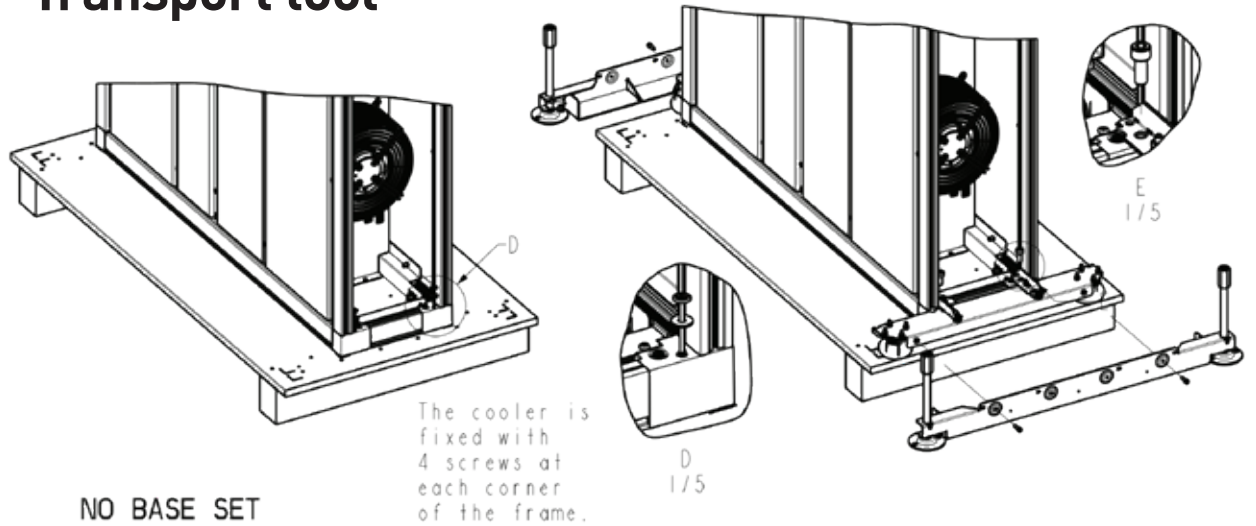

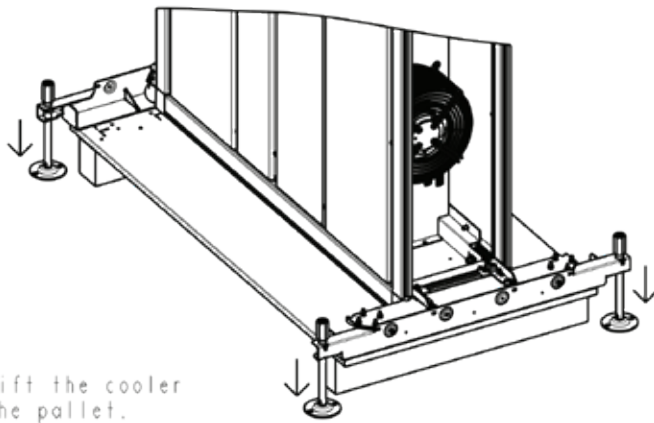

To lift the cooler of the pallet.
Mount the transport wheels and the pallet tool.
Turn the feet down to lift the cooler up.

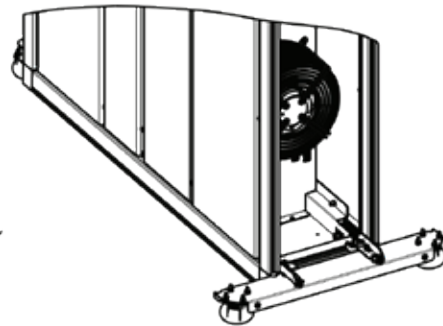

After removing the pallet, turn the feet back up again.
Use the leveling feet of the cooler to lift it a bit to remove the pallet tool.

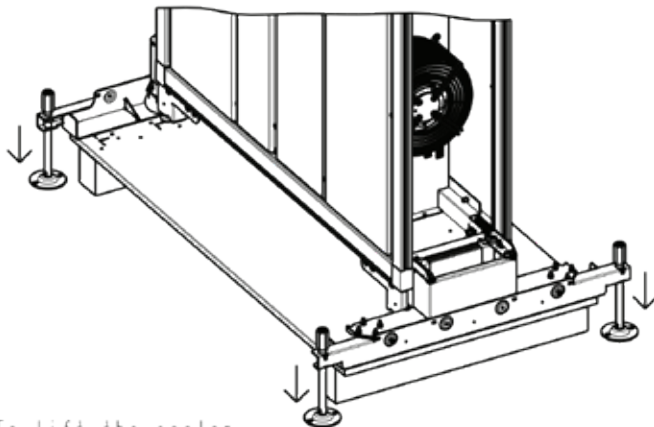

To lift the cooler of the pallet.
Mount the transport wheels and the pallet tool.
Turn the feet down to lift the cooler up.

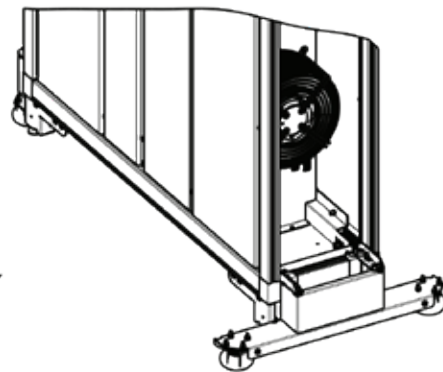

After removing the pallet, turn the feet back up again.
Use the leveling feet of the cooler to lift it a bit to remove the pallet tool.

Outer dimensions incl. packaging

	No Base set		Base set	
	42U	47U	42U	47U
Height	2092	2314	2192	2414
Width	680	680	680	680
Depth	1280	1280	1280	1280

NEXPAND

DIRECT EXPANSION | ROW-BASED COOLING

DX20 - General dimensions

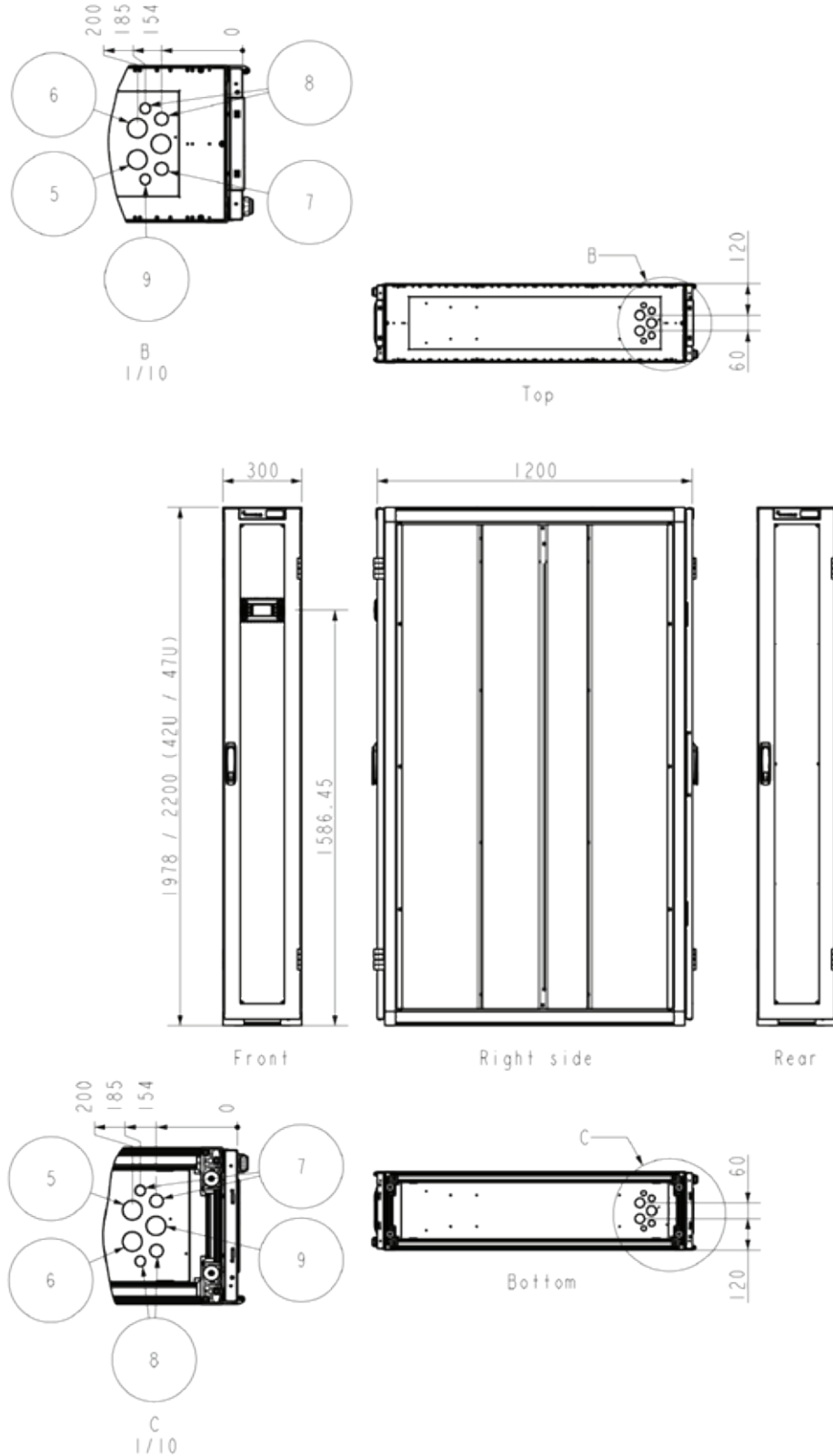

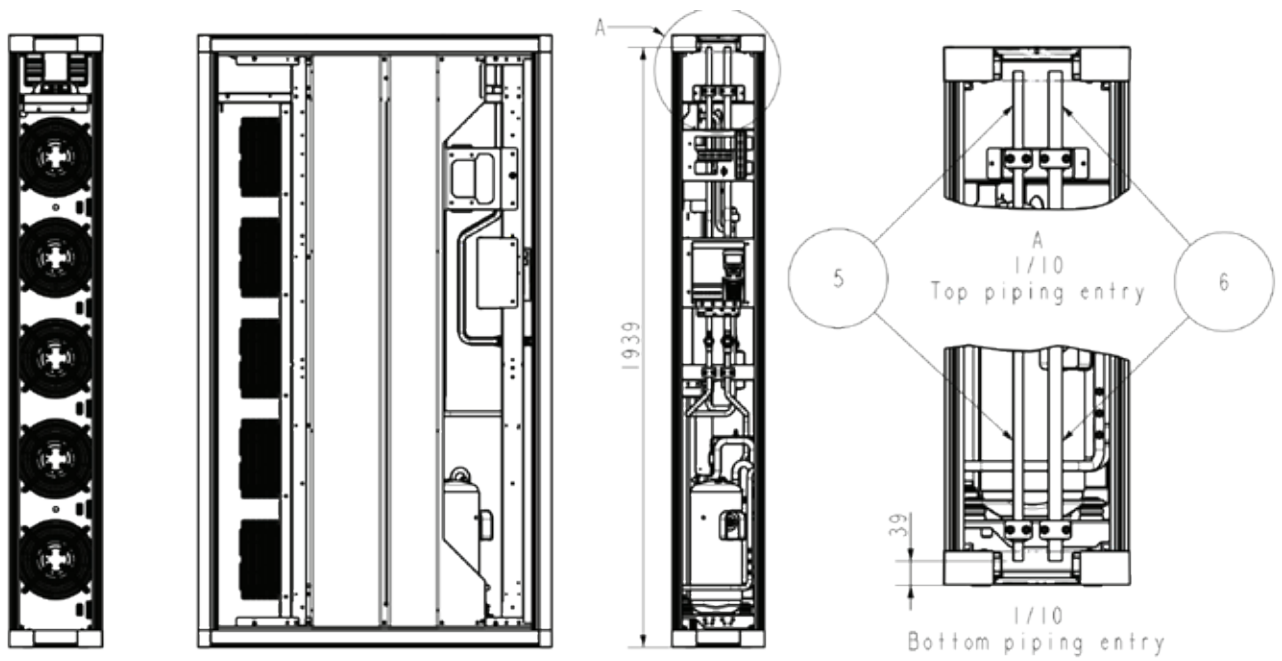

#	Description
1	Removable front door
2	Removable rear door
3	Display
4	Removable side panel
5	Liquid line inlet (rotalock 1" - Ø16)
6	Gas line outlet (rotalock 1"1/4 - Ø22)
7	Power supply
8	Data cables
9	Condensate drain

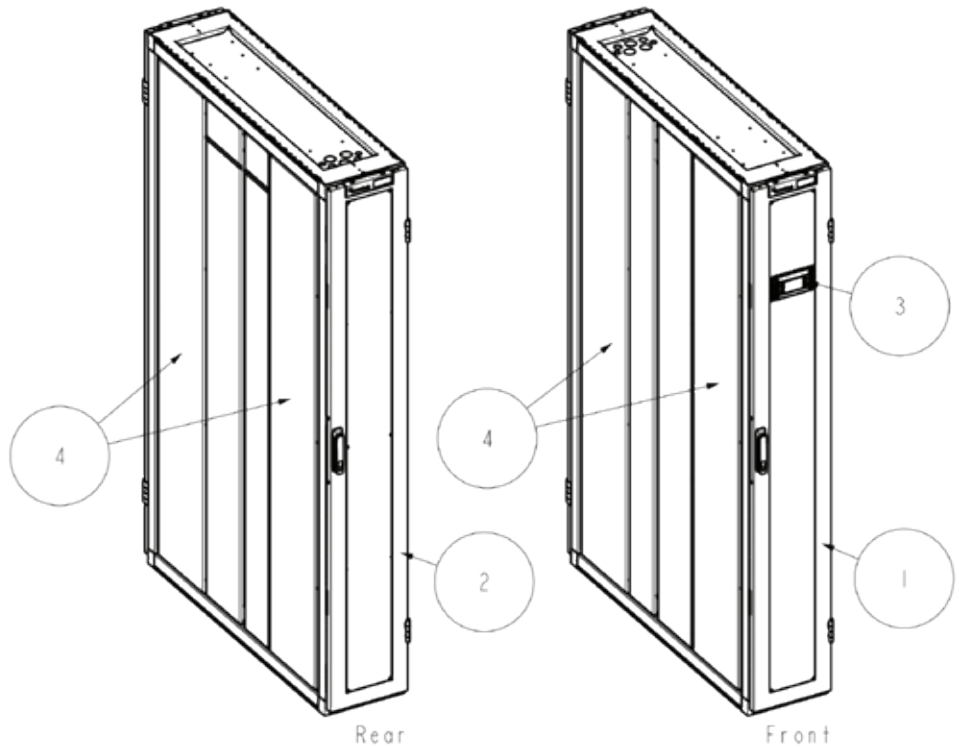

NEXPAND

DIRECT EXPANSION | ROW-BASED COOLING

DX20 - Transport tool

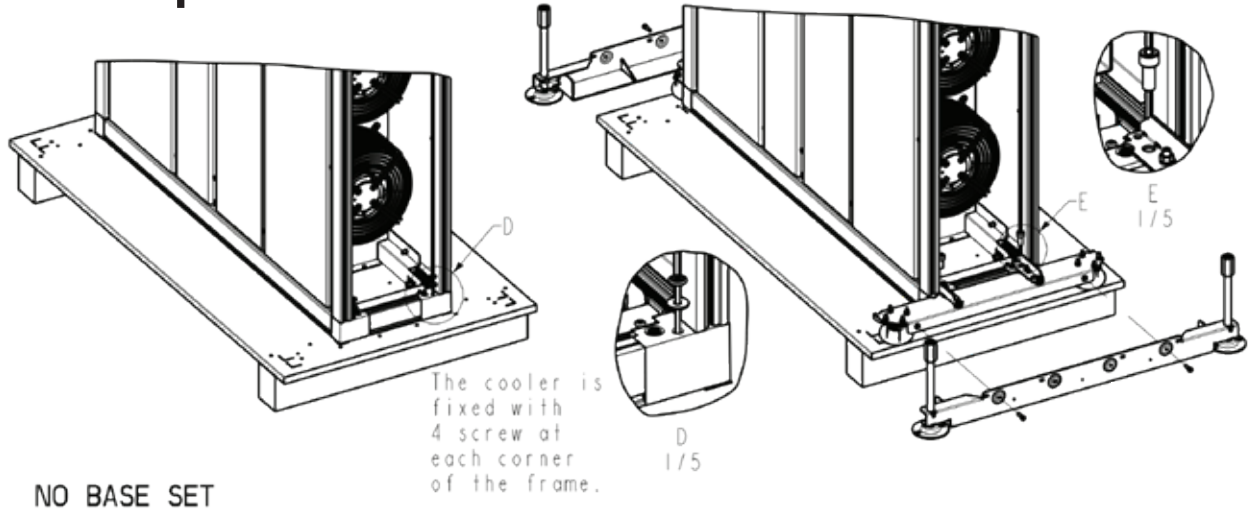

NO BASE SET

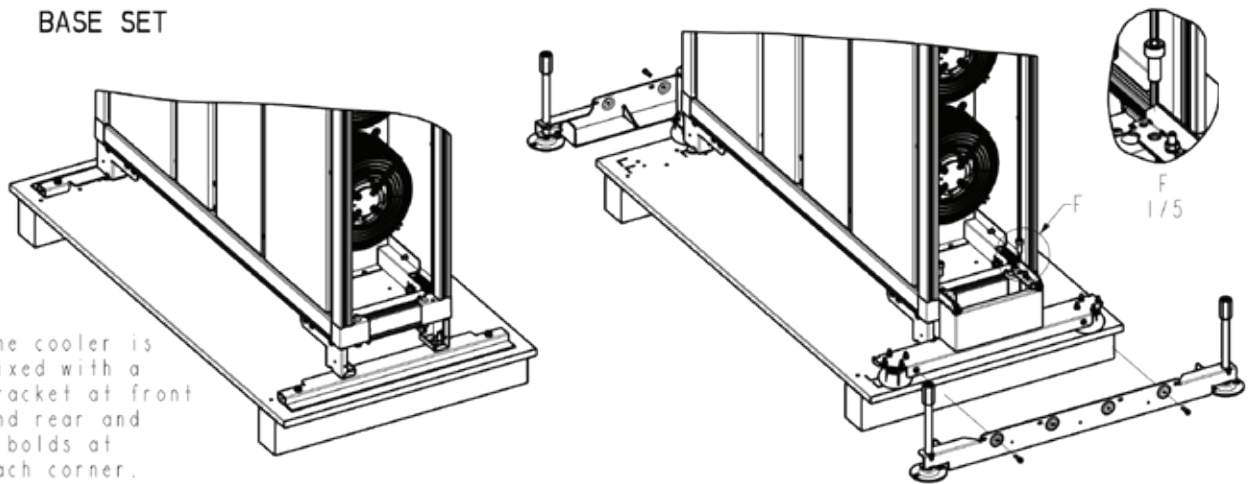

BASE SET

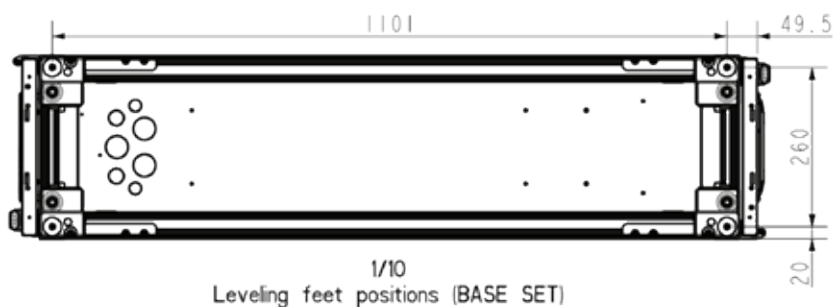
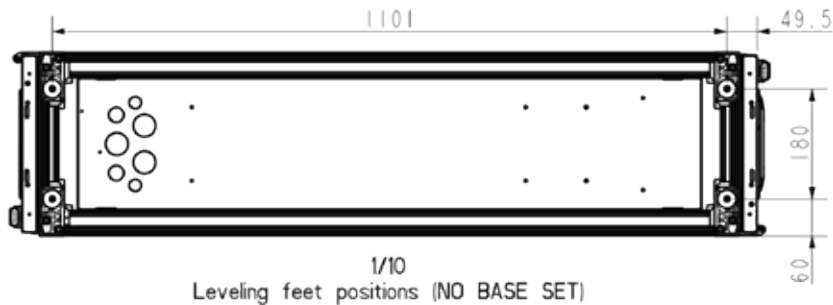

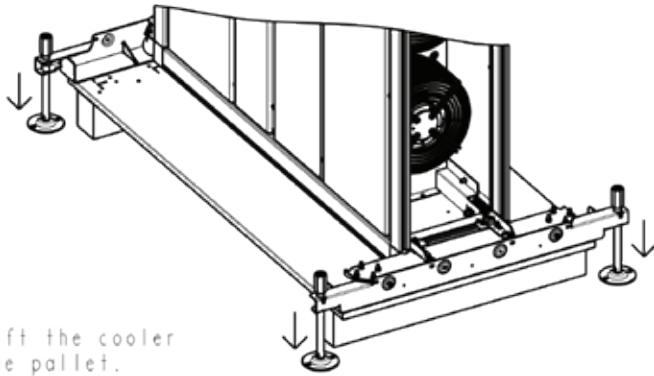

To lift the cooler of the pallet.
Mount the transport wheels and the pallet tool.
Turn the feet down to lift the cooler up.

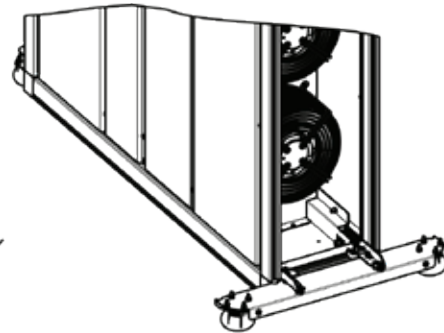

After removing the pallet, turn the feet back up again.
Use the leveling feet of the cooler to lift it a bit to remove the pallet tool.

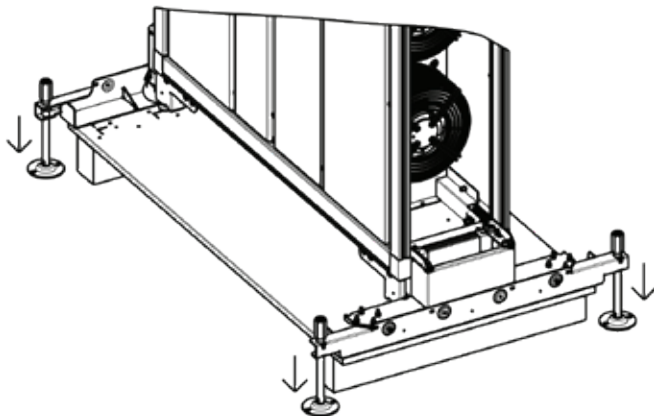

To lift the cooler of the pallet.
Mount the transport wheels and the pallet tool.
Turn the feet down to lift the cooler up.

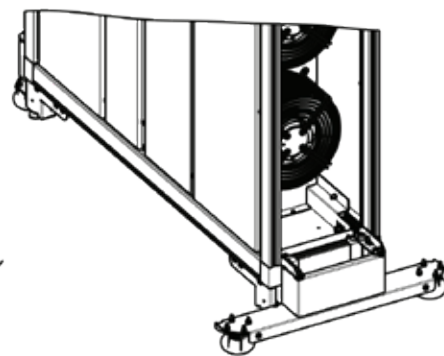

After removing the pallet, turn the feet back up again.
Use the leveling feet of the cooler to lift it a bit to remove the pallet tool.

Outer dimensions incl. packaging

	No Base set		Base set	
	42U	47U	42U	47U
Height	2092	2314	2192	2414
Width	680	680	680	680
Depth	1280	1280	1280	1280



FOLLOW US ON

@ website: www.legrand.eg

f legrand

legrandegypt



EMB Electrical Industries S.A.E.

Headquarter office

Pyramids Heights Office Park
KM 22 Cairo - Alex. desert road
Building 1B, 12556
Tel.: +202 3536 0000
Fax: +202 3536 0001
www.legrand.eg